



Residential and Commercial Solutions from Growatt

MIN / SPH / SPE / WIT



Business Focus

Growatt is a new energy enterprise dedicated to the R&D and manufacturing of PV inverters, Energy Storage, EV Charger, and Smart Energy Management solutions.



PV Inverter

Energy Storage

EV Charger

Portable Power

About GROWATT

Remarkable volume of global cumulative shipments

3.8M+

PV Inverters Shipment

700K+

Storage Inverters Shipment

6M+

Cloud users

3.1M+

Inverter Production capacity +400K bat

180+

Countries with systems installed

4,400+

Employees

1,100+

R&D engineers

4.6%

Revenue invested in R&D for 2022

Global Presence

44 Representative Offices and Warehouses. Products installed in more than 180 countries or regions worldwide.



Global Leading Distributed Energy Solution Provider



Hybrid
inverter Supplier



Residential PV
Inverter Supplier



Commercial PV
Inverter Supplier



Source: S&P Global Commodity Insights

Milestone History

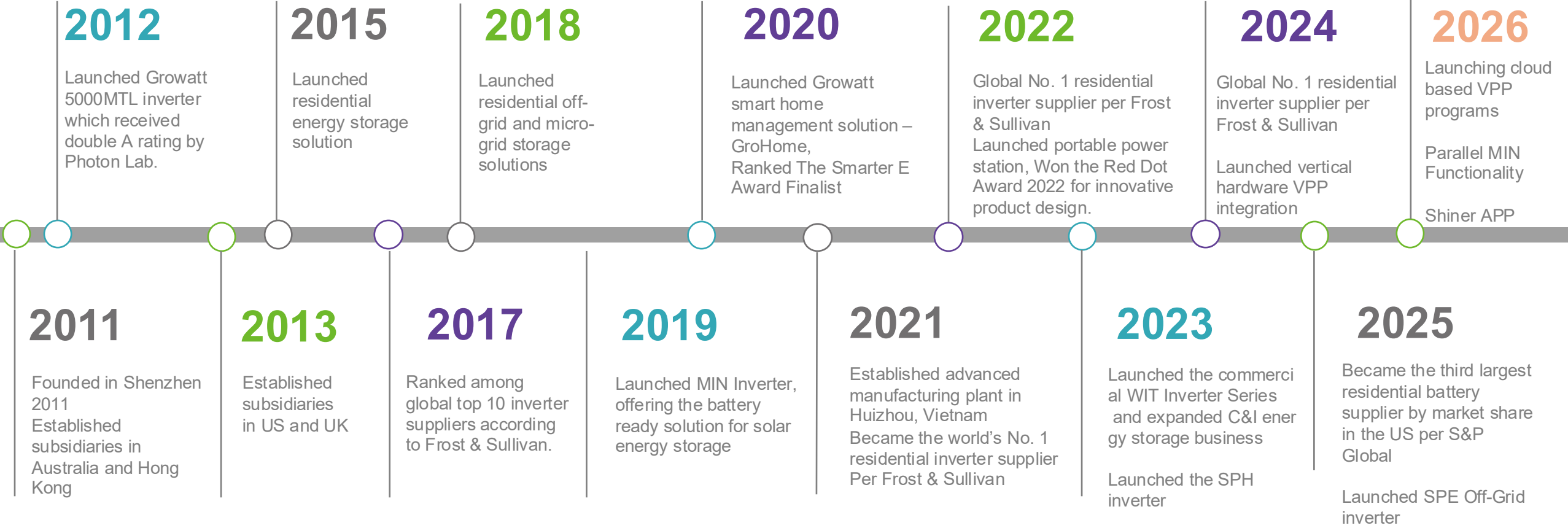

Advanced Manufacturing Center

Annual Capacity of 3.1 Million Inverters and 400K Battery Packs
Highly Automated Production Line
Execute Growatt 5-Steps Quality System



Advanced Manufacturing Center Vietnam

Highly Automated Production Line
Execute Growatt 5-Steps Quality System



Growatt U.S.A. Team Allocation Map

Field Application Engineers



Field Service Engineers

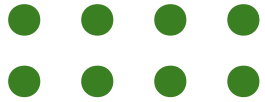

Sales



Project Managers

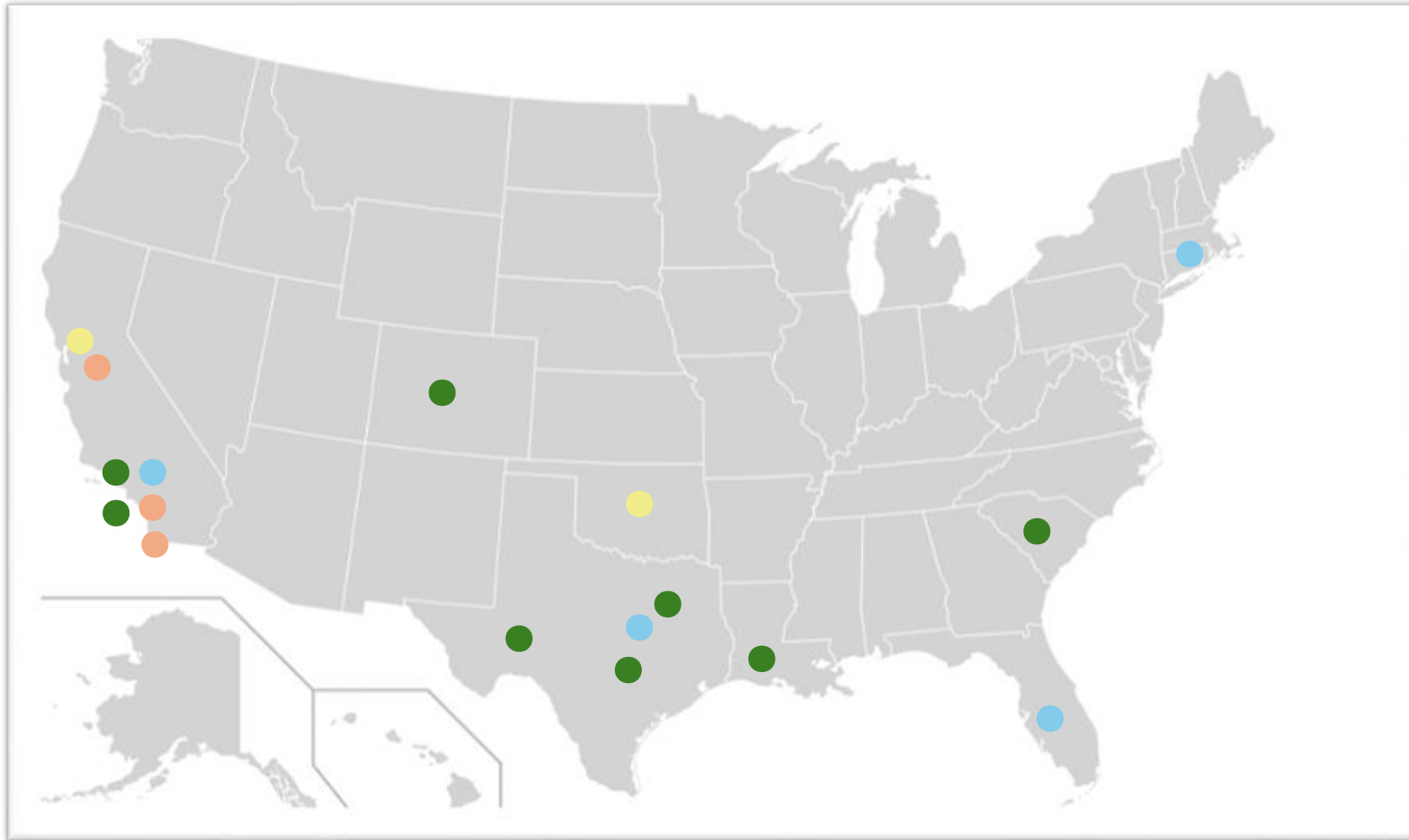

Call Center 7am – 6pm PST (866)-686-0298 usaservice@ginverter.com



To Build the World's Largest
Intelligent Sustainable Energy Ecosystem for Humankind

**FUTURE PROOF
BATTERY READY PV SOLUTION**



2026 Product Introductions



SHENZHEN GROWATT NEW ENERGY CO.,LTD

GROWATT

2026 Product Lineup

MIN Residential Inverter
3.5-11.4K



APX Battery (HV)
5-30 kWh

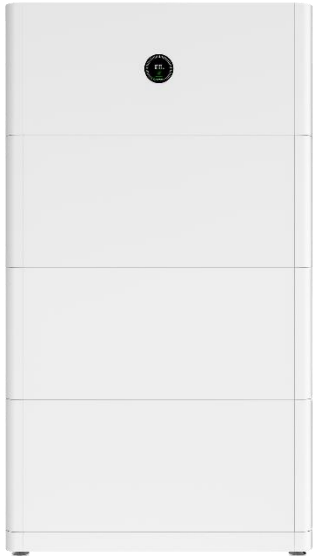

SYN Transfer Switch
200A

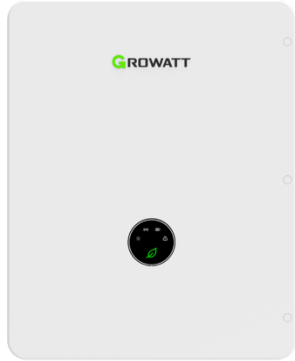

AC EV Charger
7-12K



WIT Commercial Inverter
28-100K

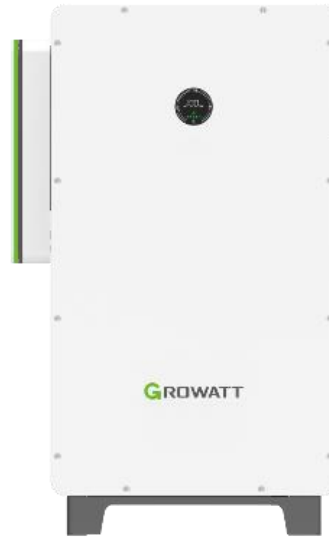

SPH Residential / Commercial Inverter
8-16K



ALP Battery (LV)
5-320kWh



SPE Off-Grid Inverter
8-12K



ALP Battery (LV)
5-320kWh



Portable Power Stations
0.5-3.6 kWh





MIN-TL-XH-US Inverter



SHENZHEN GROWATT NEW ENERGY CO.,LTD

GROWATT

Battery Ready PV System for Your Home

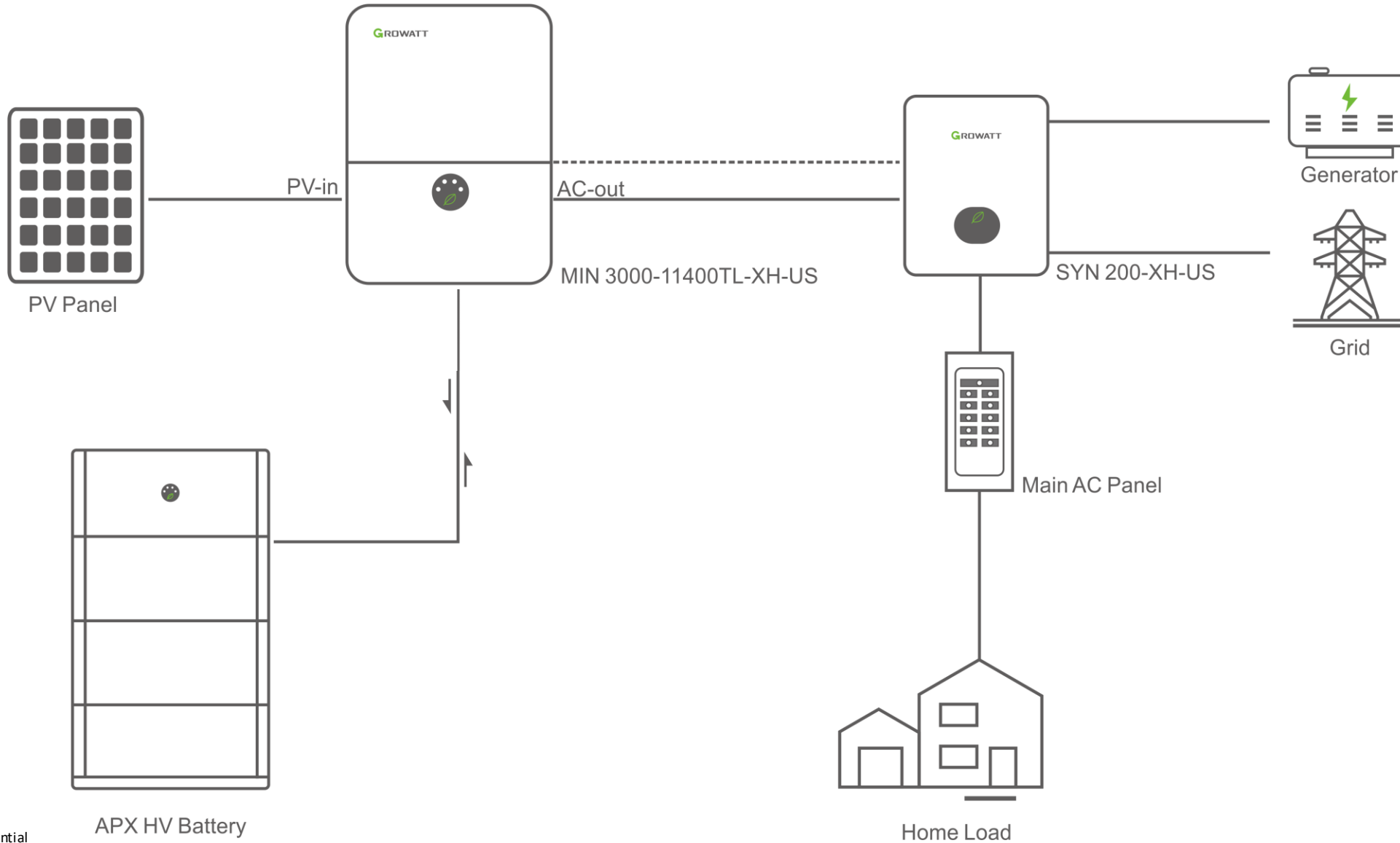

Product Overview - Battery Ready Inverter – MIN 3.5 – 11.4K



MIN TL-XH-US Single Phase Battery Ready Inverter

General

- Output Power 11400W
- Streamline design
- Compact: 3.5-11.4 kW , 7.6kW 32.3 lbs
- UPS <500 ms
- 4 MPPT's
- Quick 15-minute commissioning
- Very low RMA rate

Protection

- NEMA 4X rating. Dustproof & Waterproof
- 10-year product warranty

Leading Features

- Dark start operation
- Partial and Whole home backup
- Supports generator input
- DC/AC Ratio up to 2.0
- Support RSD, AFCI and RGM meter

*Home Backup requires optional SYN backup box

Product Overview - Microgrid Interconnection Device

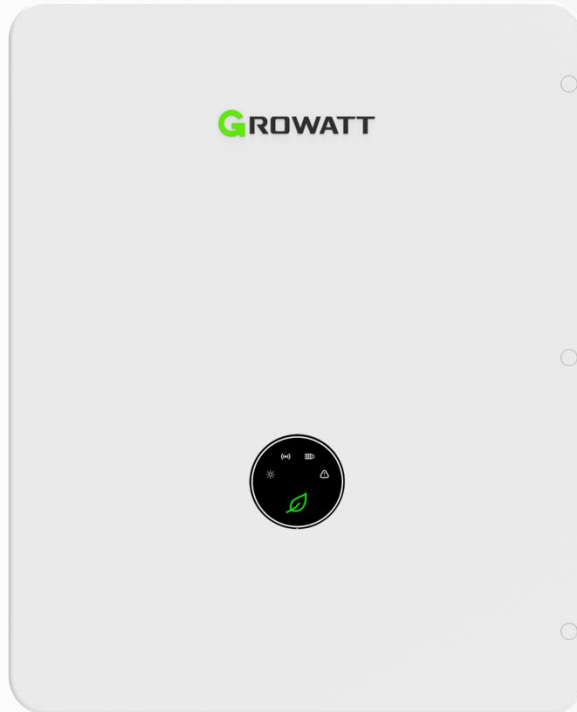

SYN 200TL-XH-US

Backup Capability

- Whole home backup power
- On/Off grid mode switch time within 0.5s

Easy Operation

- Integrated 200A breaker on the grid side
- Built-in split-phase transformer for 120V/240V output

Application Flexibility

- Service Entrance Rated
- Diesel Generator input available
- Remote wakeup and control function of Diesel Generator
- Support three working modes: Off-grid, On-grid, and Generator



APX HV Battery System

Flexible Expansion Design

5kWh-30kWh Scalable Energy Capacity

Harsh Environment Adaptability

Wide operating temperature range of $-10^{\circ}\text{C} - 50^{\circ}\text{C}$
IP 66 Design

Modular Energy Optimization

Modular level energy optimizer to guarantee each pack can be fully charged/discharged always
The new and old battery can be mixed at any time

Safe and Reliable

LFP Battery Cell
Redundancy Design
Multiple Level Protection
Automatic balancing in both pack and cell



Battery Expansion

Modular Design, More Flexible Expansion

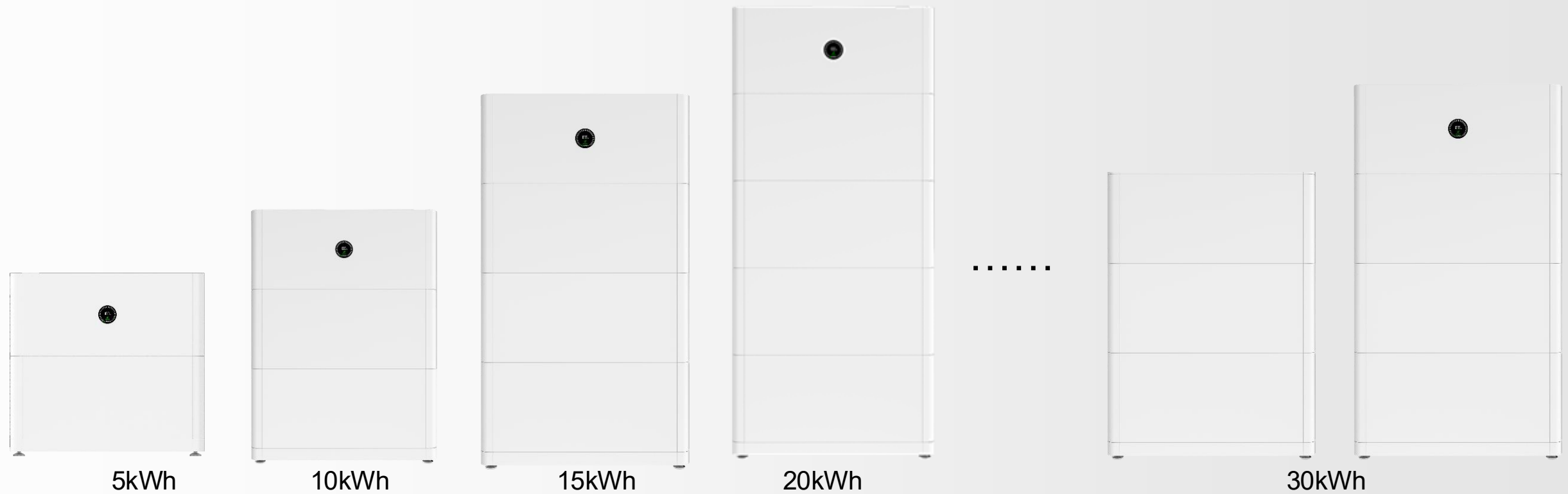

Product Overview – MIN XH2 US & SYN 23 Upgrades – Q3 2026*



MIN TL-XH-US



MIN TL-XH2-US

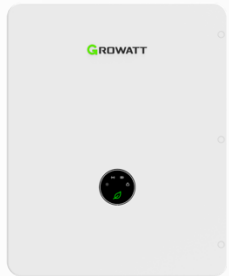

SYN 200TL-XH-US

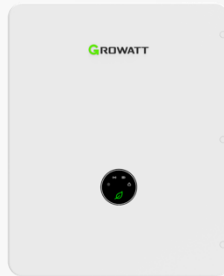

SYN 23 TL-XH-US

MIN XH2 Upgrade Key Differences – Q2 2026*

- Parallel functionality with single SYN
 - Up to 4 inverters (45.6K)
 - Up to 120kWh of back up
- Smart generator functionality with autostart
- Improved optimizer to reduce shading effects
- Max current per MPPT from 14>18A
- LRA increase from ~105>185
- Strings per MPPT from 2>1 for further optimization
- Lowering start up voltage form 80>50V
- Transfer time from 500ms>20ms

Key Reason to stay with the XH

- More Cost Effective for PV only applications

MIN DC/AC Ratio - 2.0

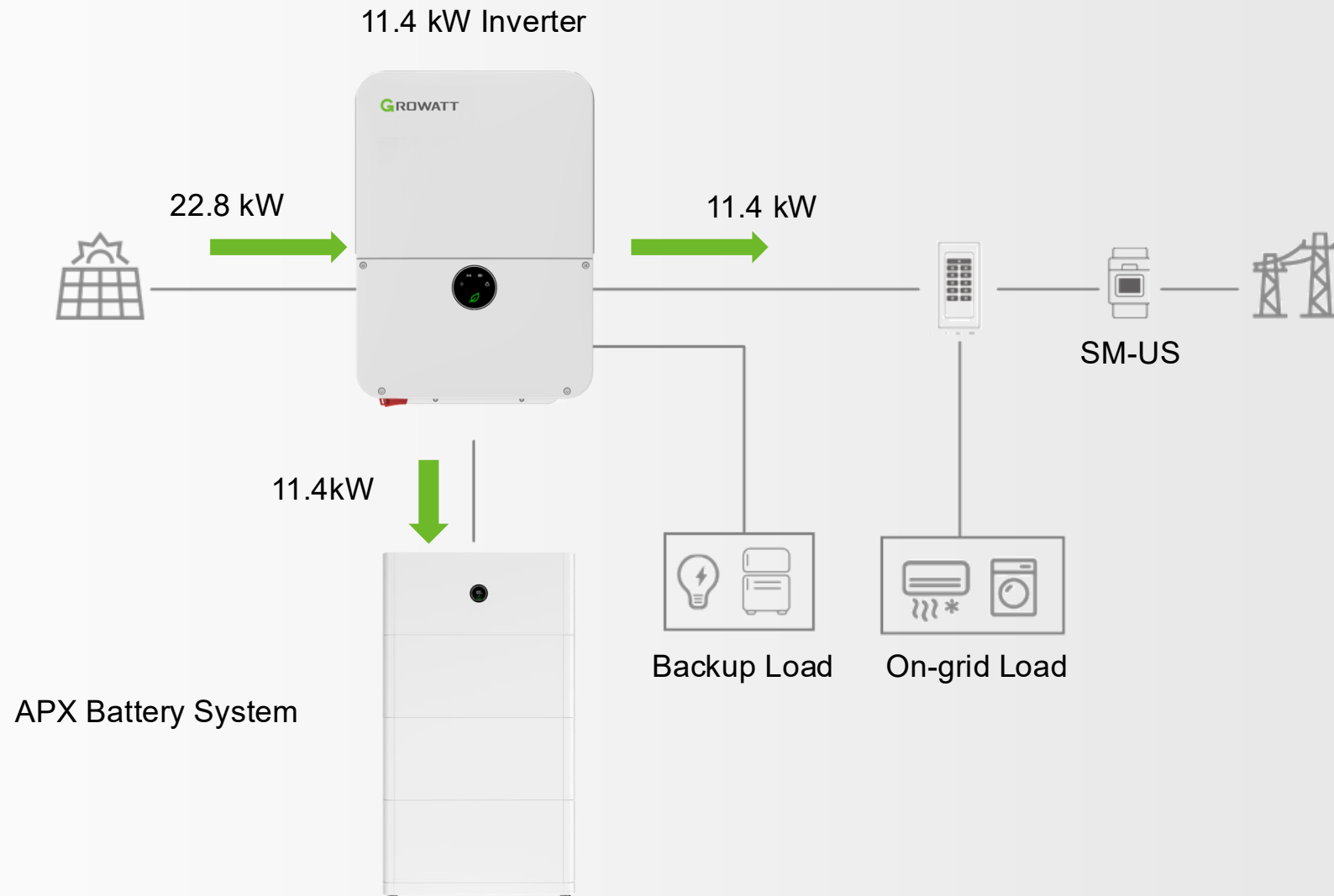

MIN AC Coupled Solution

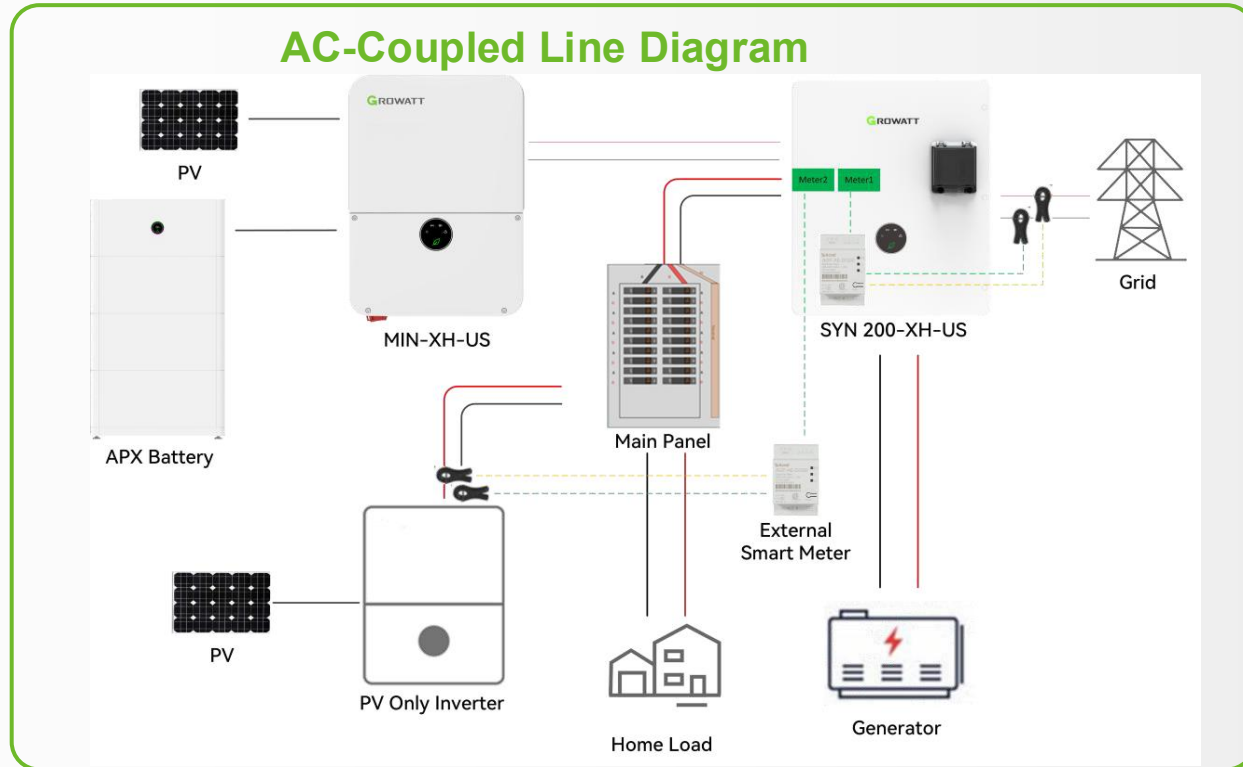

MIN-XH-US AC-Coupled Solution

The MIN TL XH US allows easy integration of batteries into existing PV only systems and is perfect for AC retrofitting.

System Solution

MIN TL-XH (Grid-Tie)

PV only

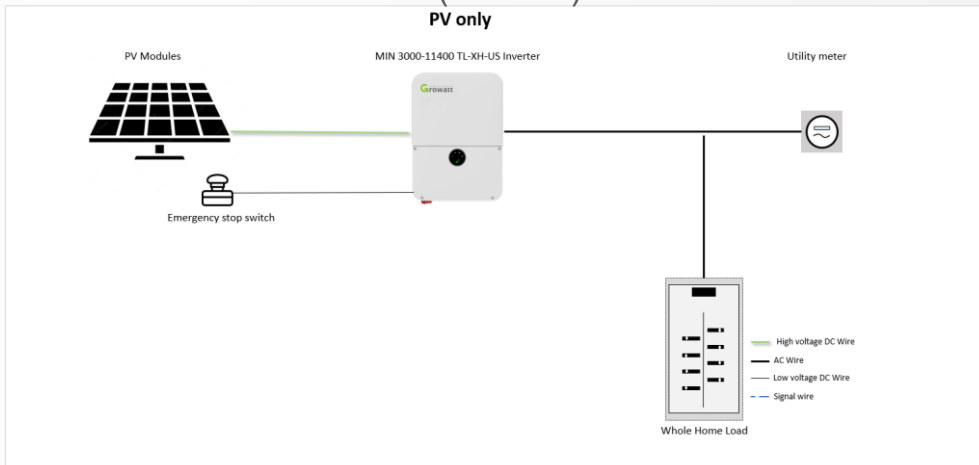

MIN TL-XH + APX (AC Couple : With or Without existing PV)

AC Coupled System

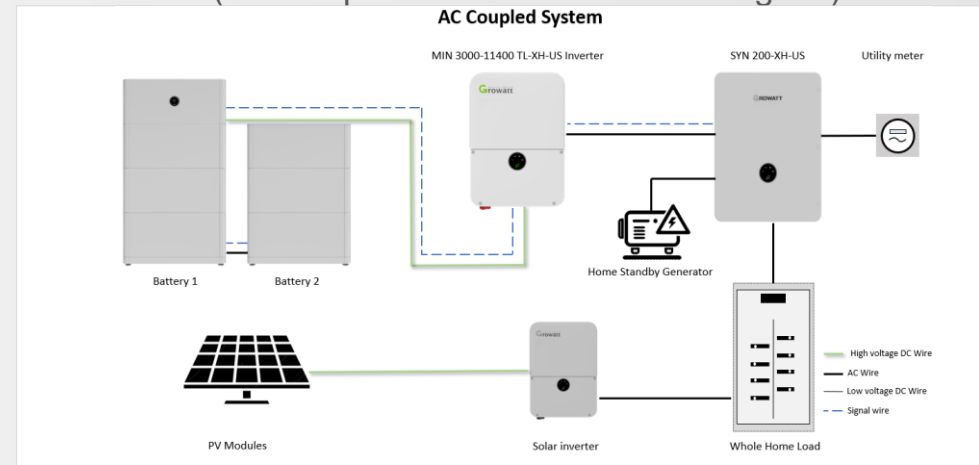

MIN TL-XH + APX + SYN (Partial Home Backup)

Partial Home Backup

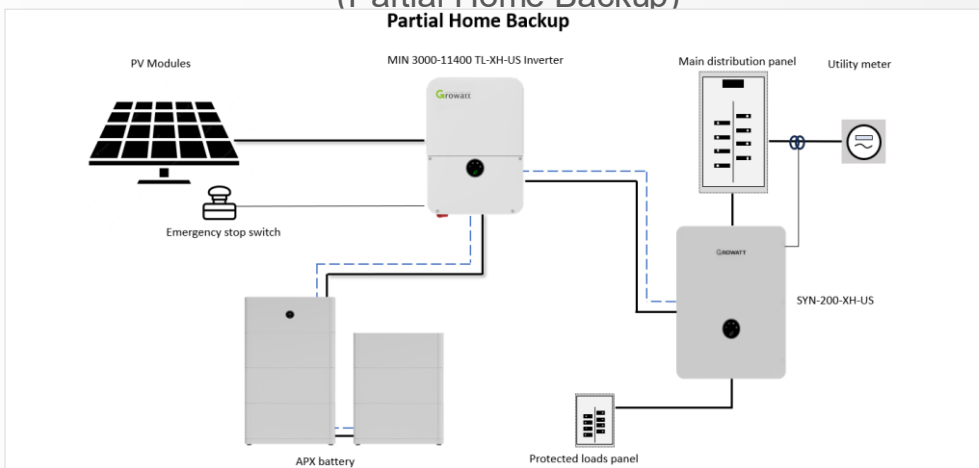

MIN TL-XH + ARO + SYN (Whole Home Backup)

Whole Home Backup

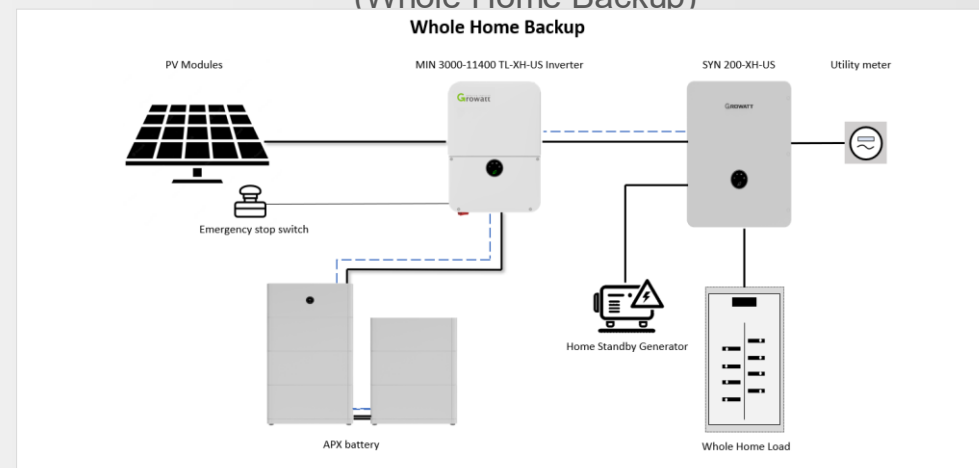

MIN TL-XH-US Inverter Installation



Full Installation Video available on Growatt New Energy YouTube Channel using link below or by searching
Growatt USA Inverter and Battery Installation Training Guide

https://www.youtube.com/watch?v=wNZwxywdzN8&ab_channel=GrowattNewEnergy



Quick Guide / Manuals / White Papers / Powerpoints
 US.Growatt.com/support/download

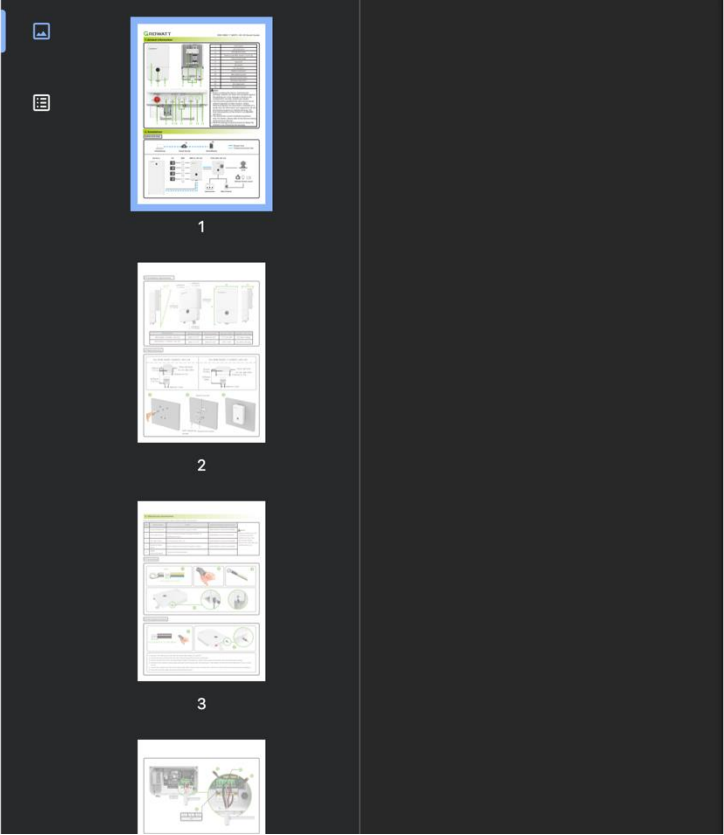

MIN 3000-11400TL-XH-US Quick Guide

1. General information

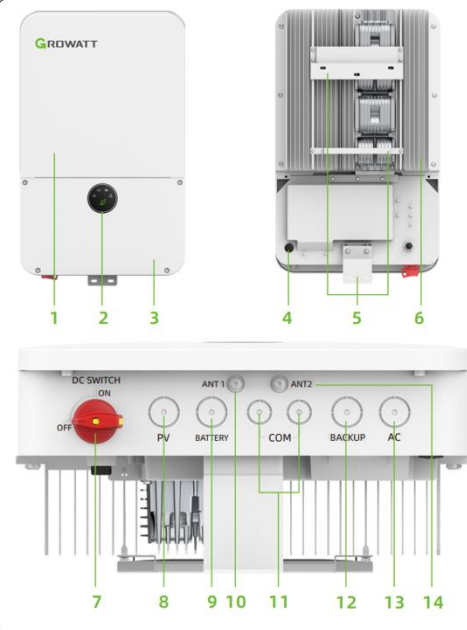

1	Host panel
2	LED indicators
3	Wiring box cover
4	Battery wake-up button or end cap
5	Mounting bracket
6	Heat sink
7	DC switch
8	PV input port
9	Battery input port
10	WiFi Antenna port
11	Communication port
12	Backup output port
13	AC output port
14	4G Antenna port

- Note:**
- Before installing the device, check that the package contents are intact and complete against the packing list. If any damage is found or any component is missing, contact your dealer.
 - This file will be updated from time to time due to product upgrades or other reasons. Unless otherwise agreed, this document is intended as a guide only. All information and suggestions do not constitute an express or implied warranty. The final interpretation of the content is at GROWATT discretion.
 - This document is quick installation guidance only. For details, please refer to the Commissioning Guide and User Manual.
 - Machine damage caused by failure to follow the content is not covered by the warranty.

2. Installation

Custom Overview

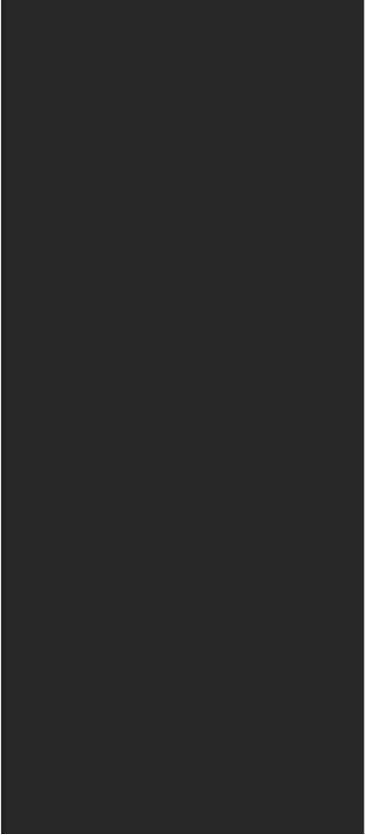

MIN TL-XH-US Inverter Installation

Material Preparation

Tools:	<ul style="list-style-type: none">● 5 MM allen key● Appropriate electrical tools● 3/4" step bit● Drill, impact, bandsaw● Level● Voltage tester
---------------	---

- Remove inverter mounting bracket and accessory pouch from box.

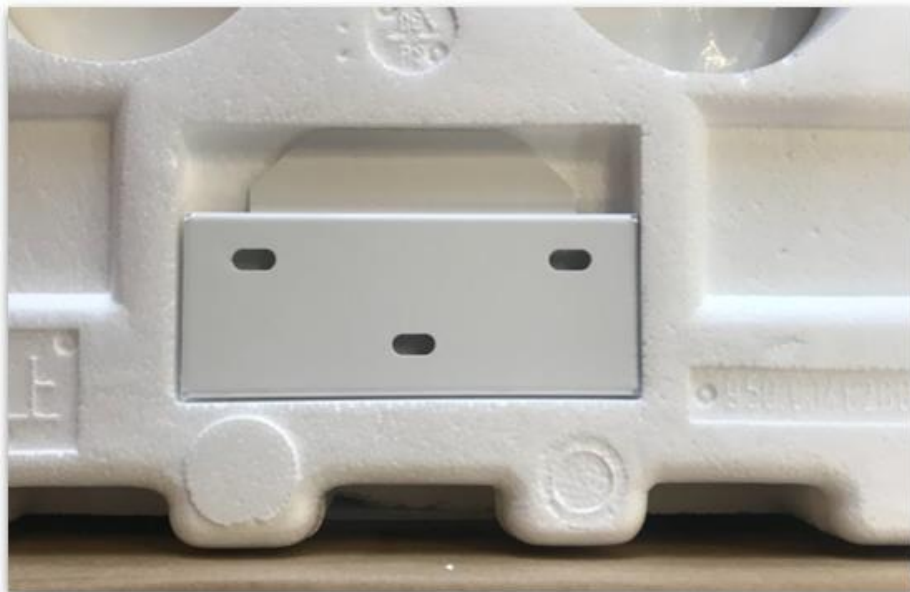

MIN TL-XH-US Inverter Installation

MIN TL-XH-US Installation requirements

- Ensure there is proper wall space to accommodate required clearances (12" on all sides of the inverter).
- Level the bracket and attach to a stud if possible, using center screw holes and appropriate anchors.
- Depending on the size of the inverter, plan for 25-35 lbs of weight to be supported.
- Mount inverter by aligning bracket tab with inverter brace and lower into place.

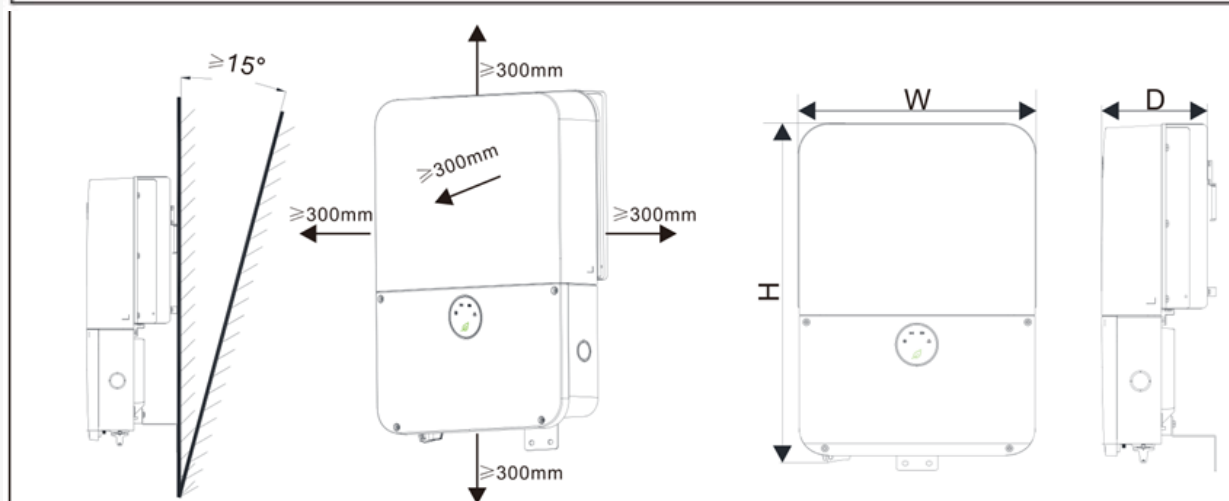
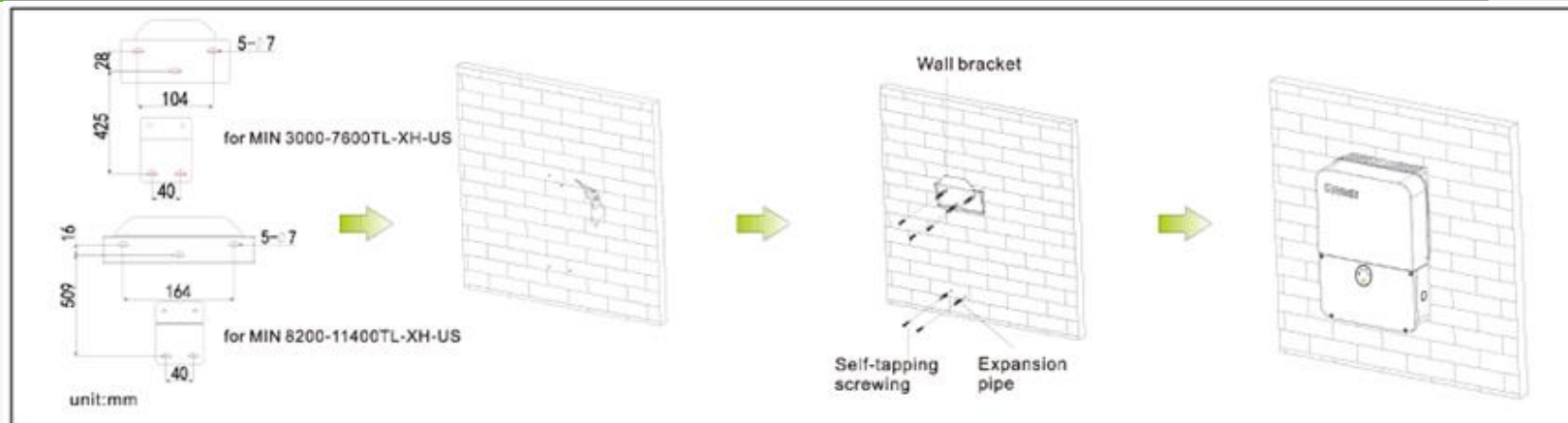

Dimsesion	W (mm/inch)	H (mm/inch)	D (mm/inch)
MIN 3000~7600TL-XH-US	400/15.75"	569/22.41"	177.5/6.98"
MIN 8200~11400TL-XH-US	400/15.75"	649/25.55"	187/7.36"



MIN TL-XH-US Inverter Installation

MIN TL-XH-US Connection Ports

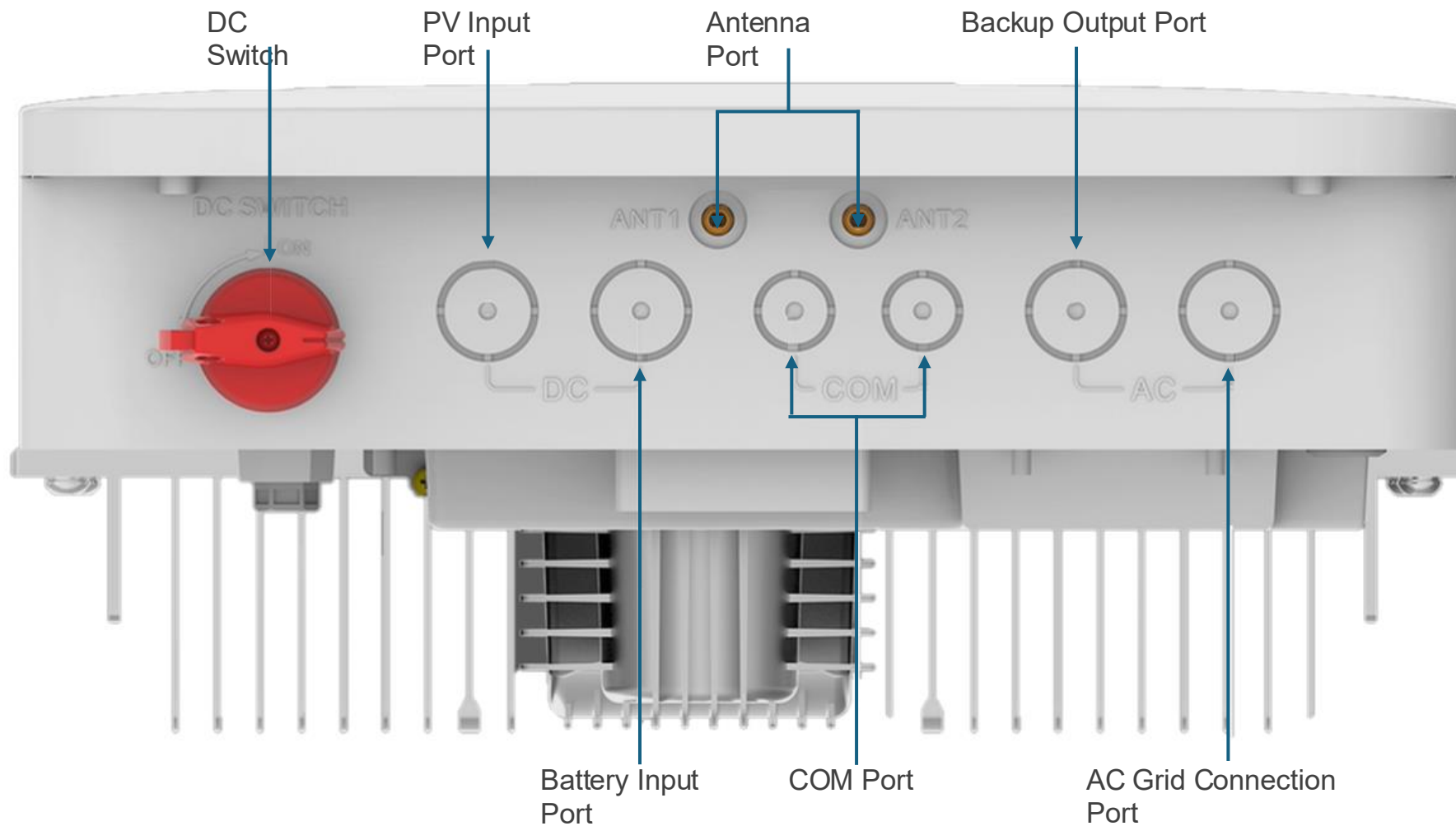

MIN TL-XH-US Inverter Installation

MIN TL-XH-US Connection Ports

COMPLETE CONDUIT RUNS

- Pre-stamped conduit entrances DC/COMM/AC, use a step bit to avoid cracking plastic shell.
- K/Os are 3/4", Comms are 1/2" (unused)
- AC + DC K/Os can be enlarged up to 1"

NOTE: The left side is NOT allowed due to RSD transmitter placement.

- ❖ TIP: For DC conduit, install a "T" fitting with a drain connector at the low point to prevent water intrusion.



MIN TL-XH-US Inverter Installation

MIN TL-XH-US Connection Terminals

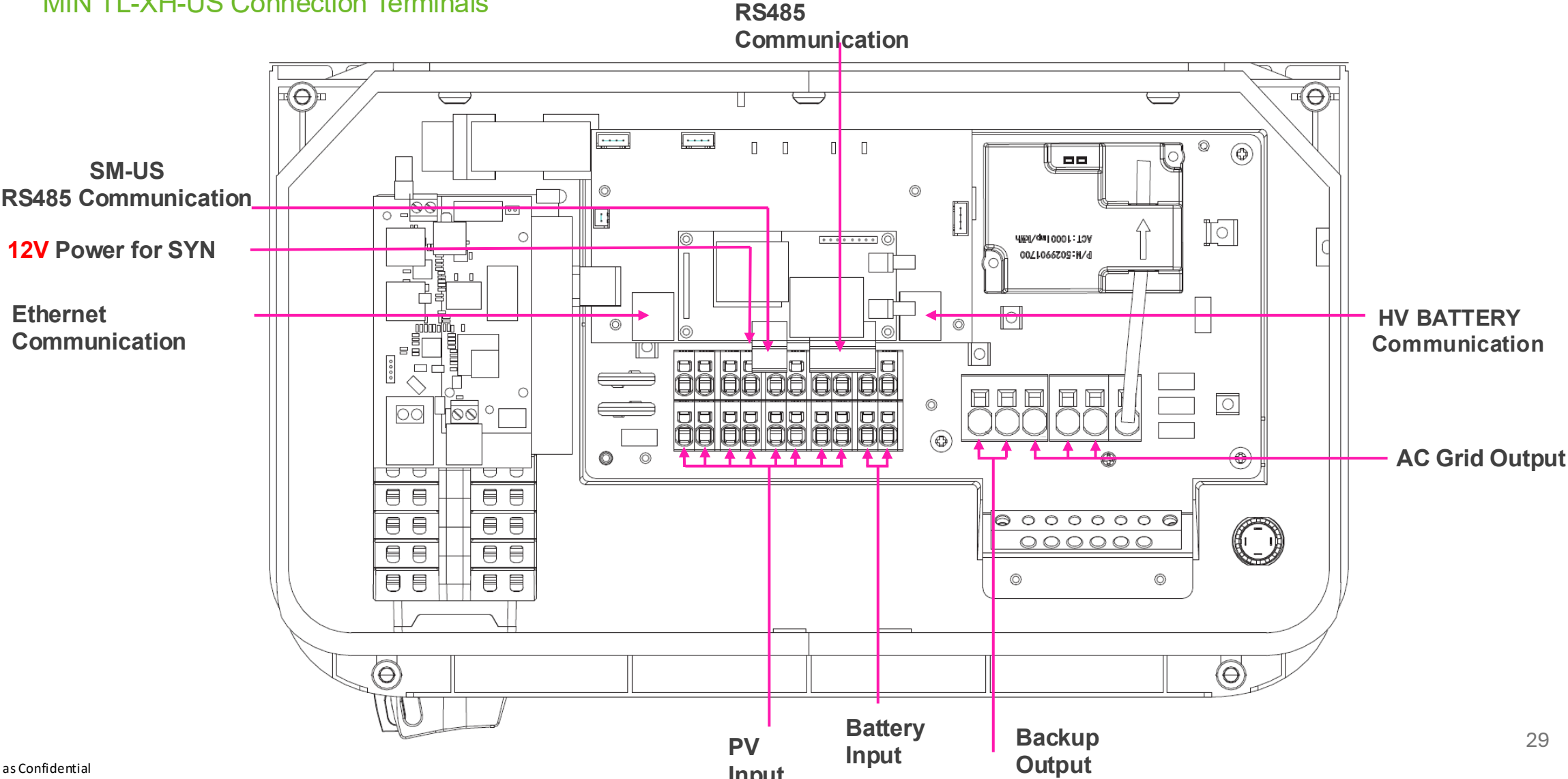

MIN TL-XH-US Inverter Installation

GRID (AC) Connection Terminals

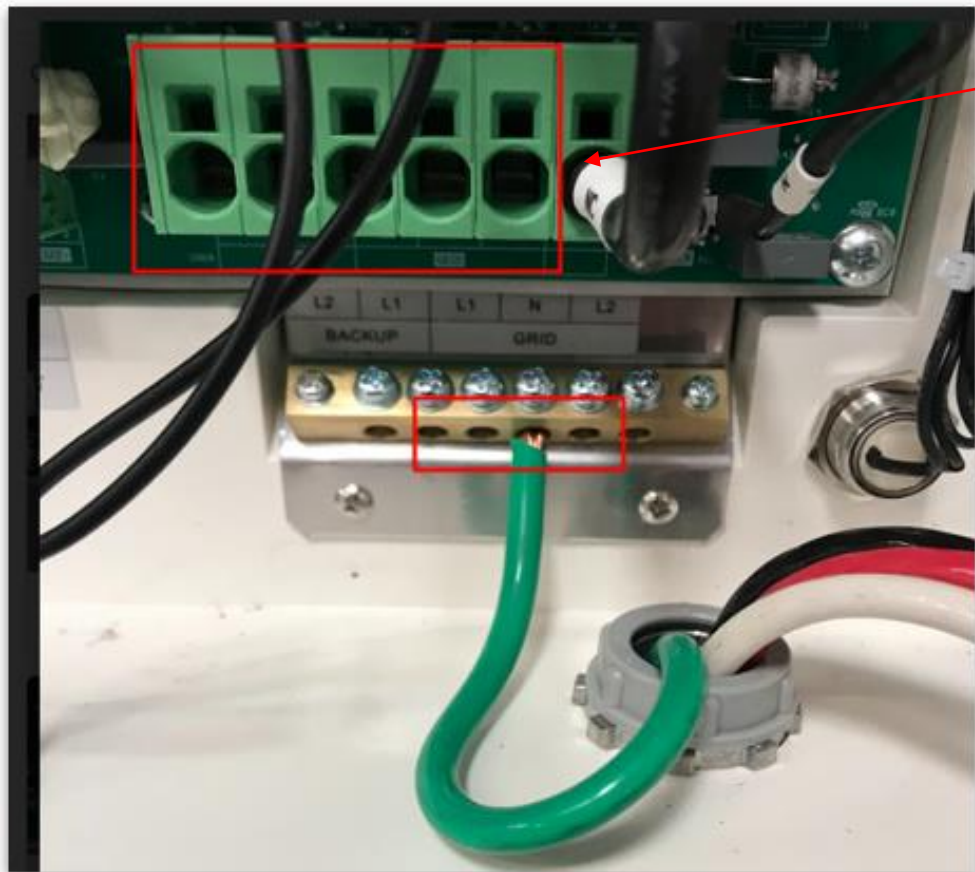

Inverter AC conductor terminals above and ground bar below

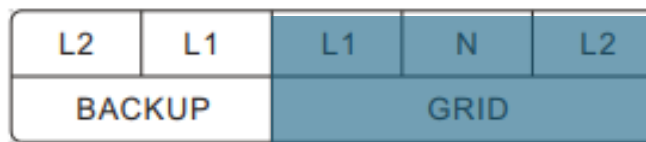

L1 N L2

AC conductors to inverter

Connection Steps:

- 1.Strip 0.7 inches (18mm) of the AC cable insulation.
- 2.Insert the AC conduit into the AC-side drill guide that was opened.
- 3.Insert the 0.8*4.0 mm standard flat-blade screwdriver and press the release mechanism and open the clamp.
- 4.Connect the cable to the appropriate terminal blocks according to the labels on the terminal blocks (L1, N, L2, of AC Grid).
- 5.Insert the cable into the round opening and remove the screwdriver, then the cable is automatically clamped.
- 6.Connect the PE to the Grounding terminal.

NOTE: The neutral in the Growatt inverter is in the center terminal.

MIN TL-XH-US Inverter Installation

PV and BAT (Battery) Connection Terminals

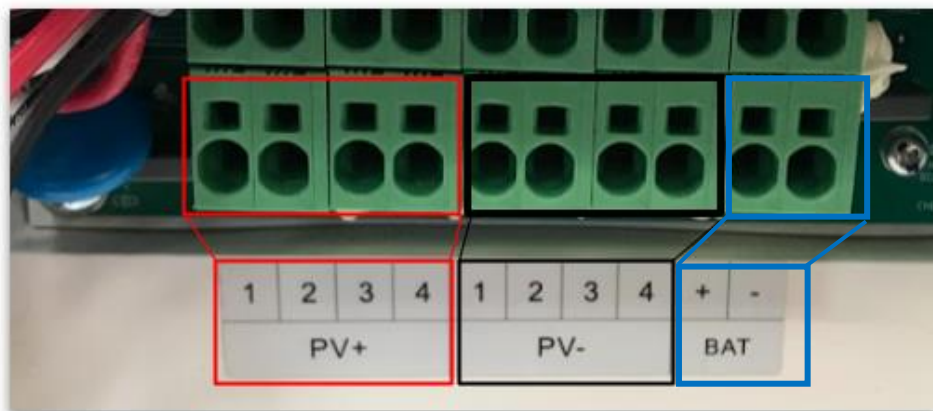

Inverter PV DC terminal blocks



PV conductors

Connection Steps:

1. Turn PV Switch to OFF position
2. Connect Battery cables to BAT + / - terminals
3. Connect PV cables to the PV+ 1/2/3/4 & PV- 1/2/3/4 terminals
4. Connect the Ground cable from PV panels to the PE terminal

PV Configuration Limitations:

- Max. Voc voltage: 600Vdc
- Max Vmp voltage: 500 Vdc (derate from 500-550Vdc, Standby 550-600Vdc)
- Max. PV Input Current Per MPPT: 13.5A
- Max. Short Circuit Current Per MPPT: 16.9A
- Max. Recommended PV Power (STC): Up to 2x the AC rating of the inverter

MIN TL-XH-US Inverter Installation

Emergency Stop Switch (optional)

- In the inverter find the 3-port RS485 connector to the left of the pv terminal.
- Remove prewired jumper from port 1 and 3.
- Land the white/orange in the connector's left terminal and the orange in the right terminal.
- Install 3-pin connector into the terminal block.

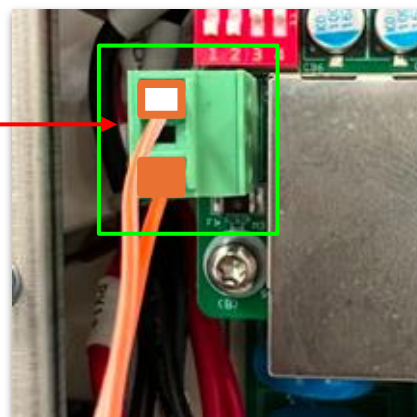
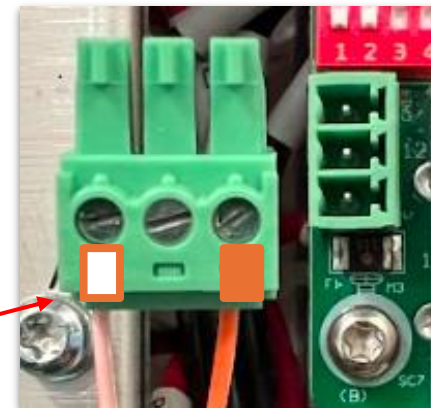
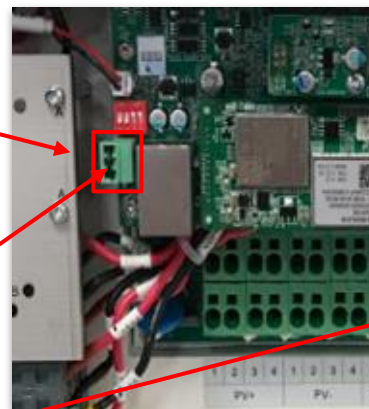

MIN TL-XH-US Inverter Installation

Emergency Stop Switch (optional)

- Land 16-12 AWG wire in the switch terminals.
- Port 1 **black**, port 2 **red**
- Connect the transmission cable to the 16-12 AWG using 12-24 AWG WAGO connectors
 - **Black** to White/Orange
 - **Red** to Orange

NOTE: E-Stop Switch application and compliance varies by jurisdiction. Check your AHJ for local requirements.

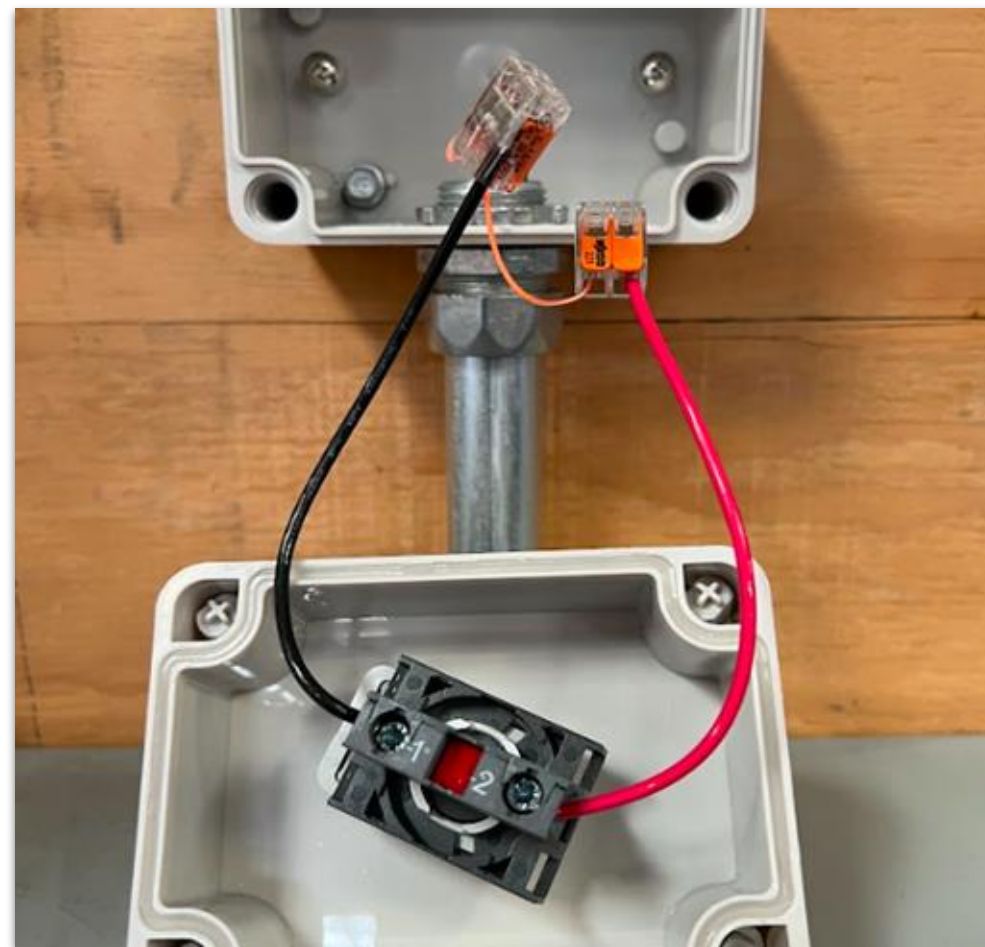

MIN TL-XH-US Inverter Installation **CONNECT EMERGENCY STOP SWITCH (MULTIPLE INVERTERS)**

Emergency Stop Switch (optional)

- If there are multiple inverters on site, splice the CAT5 cable wires (white/orange to white/orange and orange to orange) with 3 port 12-24 AWG WAGO connector using two of the 3 ports inside of an inverter enclosure or the Emergency Stop Switch housing.
- Connect 16-12 AWG wire using third port of the 12-24 AWG WAGO connectors and land 16-12 AWG wire in the switch terminals.
 - **Black** to White/Orange
 - **Red** to Orange

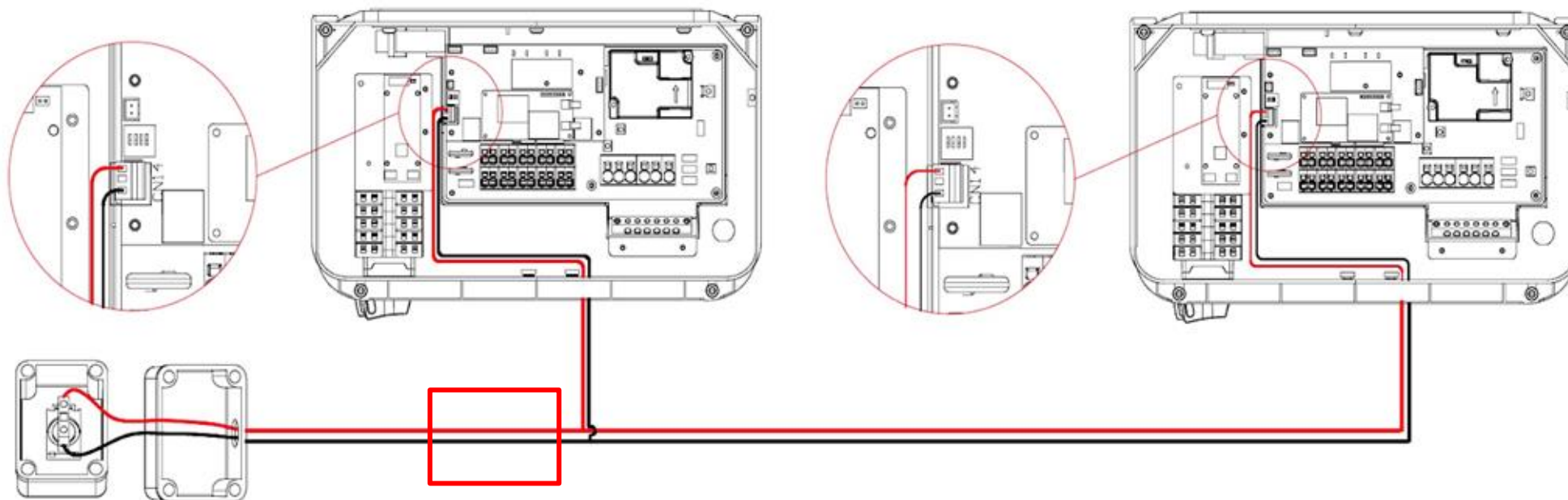

MIN TL-XH-US Inverter Installation (ATS-US ONLY)

BACKUP Connection Terminals

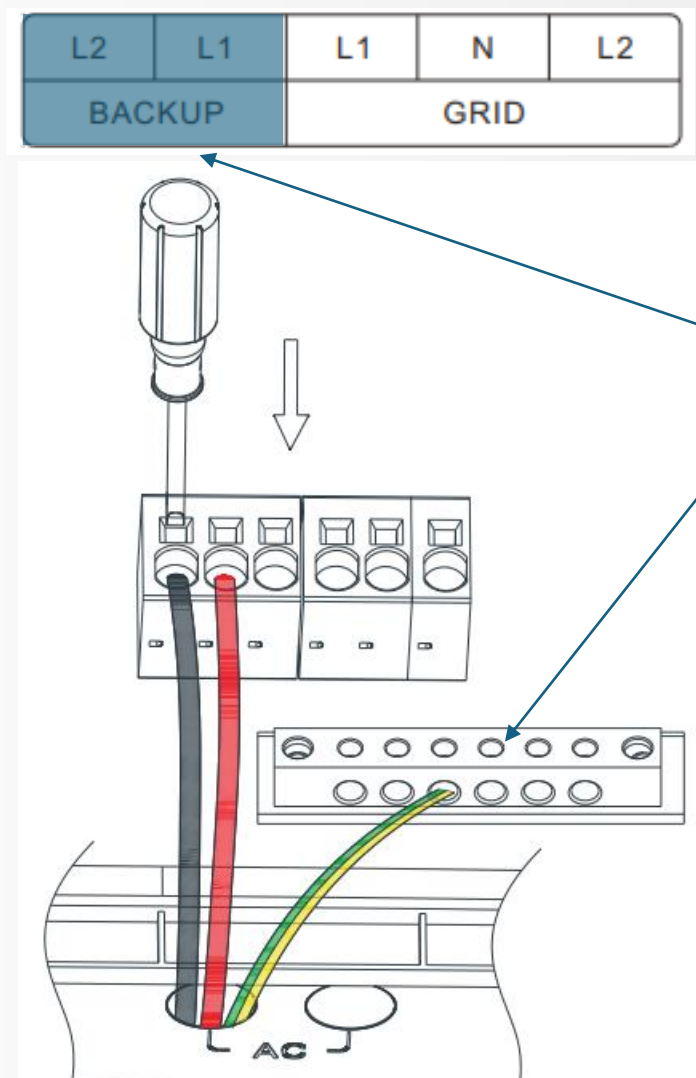

Connection Steps:

1. Connect the L1 & L2 BACKUP wires going to the ATS-US
2. Connect the PE (Ground) wire going to ATS-US

Note:

DO NOT connect the BACKUP outputs & GRID outputs together



MIN TL-XH-US Inverter Installation

Grounding and Antenna Connections

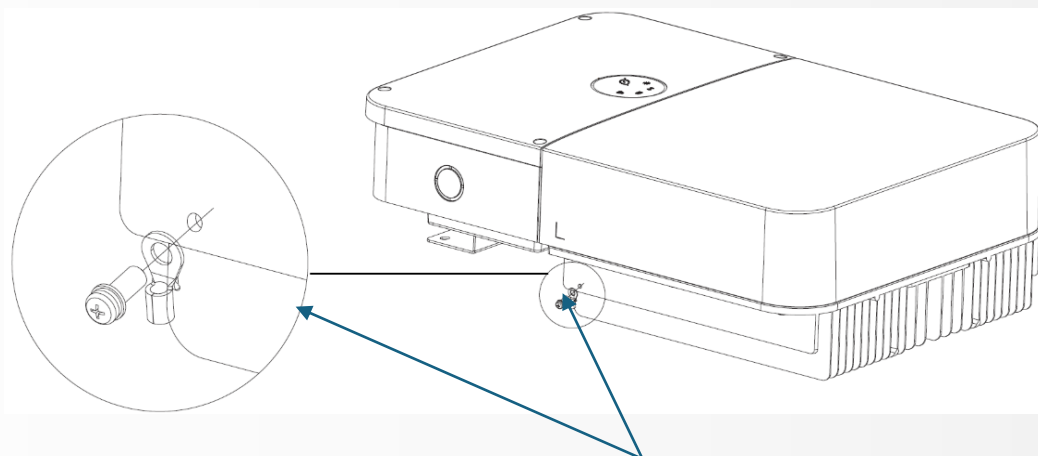

The Ground connection is located on the right-hand side of the inverter.

- Remove the antenna from the accessory bag and install to corresponding ports on the bottom side of inverter. Hand tighten only.

NOTE: 4G and WiFi have a different Male/female connection to avoid incorrect installation.

- 4G has a grey collar and should be installed on the right hand port.

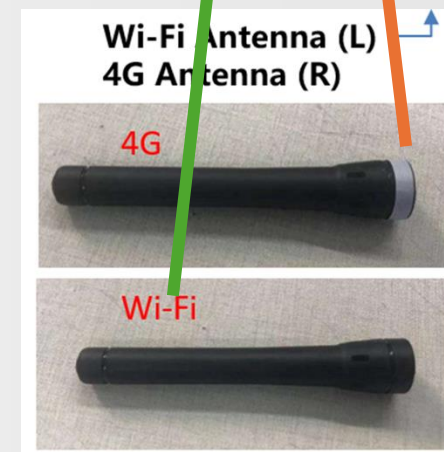
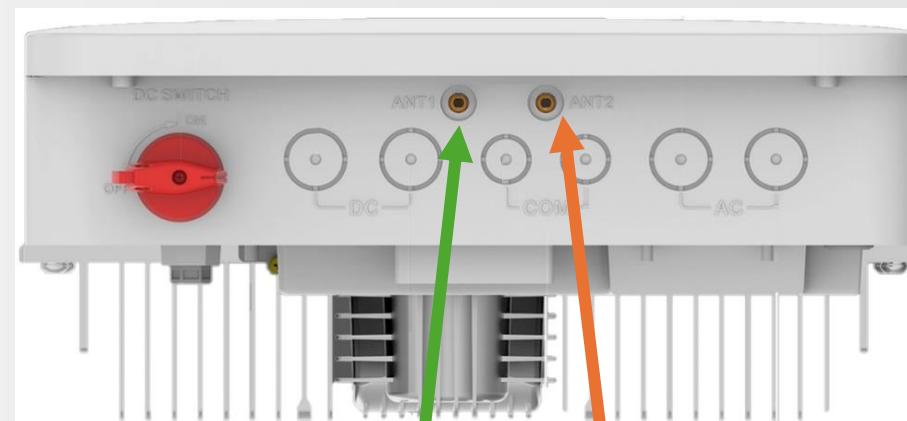

Wi-Fi Antenna to **ANT1** located at **LEFT**

4G Antenna to **ANT2** located at **RIGHT**



SM-US Smart Meter Installation (optional)

*SYN has Smart Meter Pre-installed



SM-US Smart Meter Installation

SM-US & CT Installation

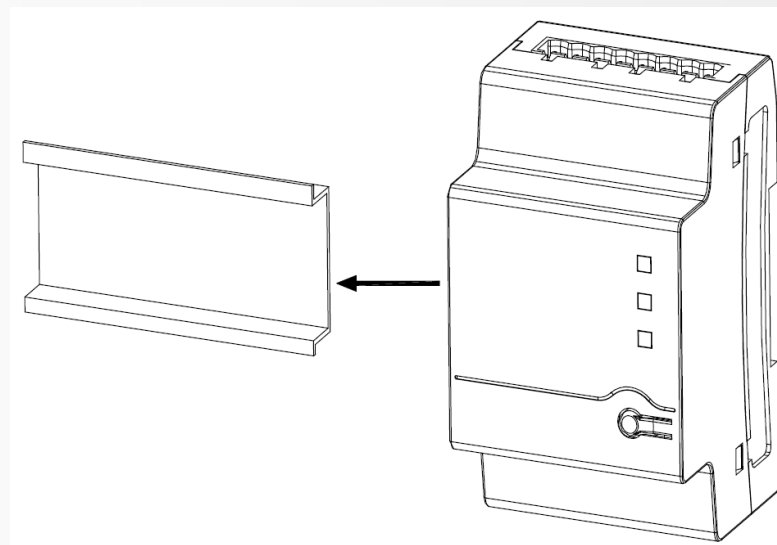

Connection Steps:

1. The SM-US & CT's should be installed inside of the main distribution panel. The meter should be mounted in the panel using 35mm DIN Rail
2. Install CT's on the AC cables between the Load and Grid
3. Open the CT'S to check direction arrow labeled which indicates the current direction and the direction of the arrow means the direction from **GRID to LOAD**



SM-US Smart Meter Installation

SM-US & CT's Wiring

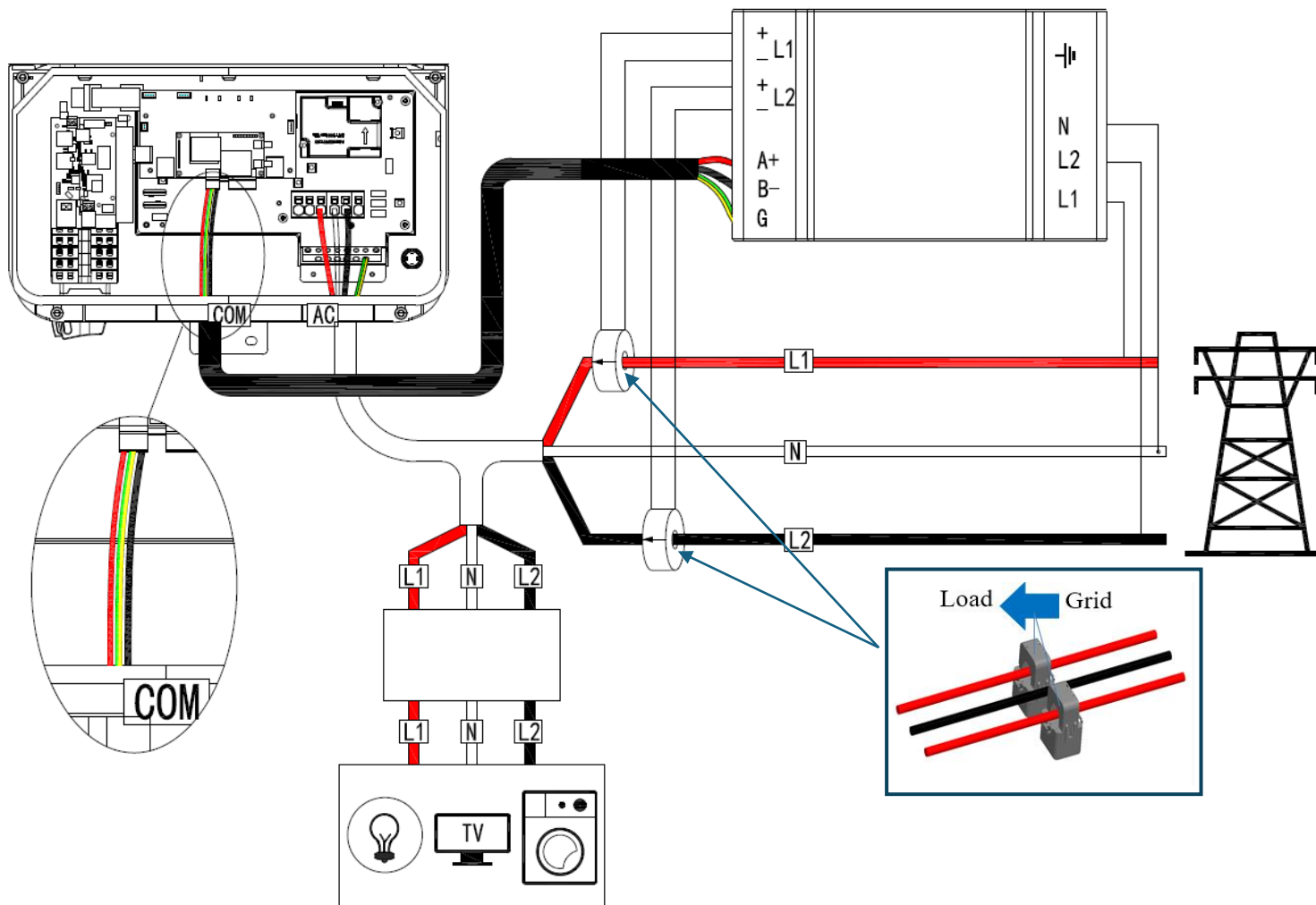

NOTE: Meter AC L1 should read 0v AC to Grid L1 where L1 CT is placed. 240v AC means CT will show out of phase/reverse reading.

SM-US Smart Meter Installation

SM-US RS485 Wiring Configuration

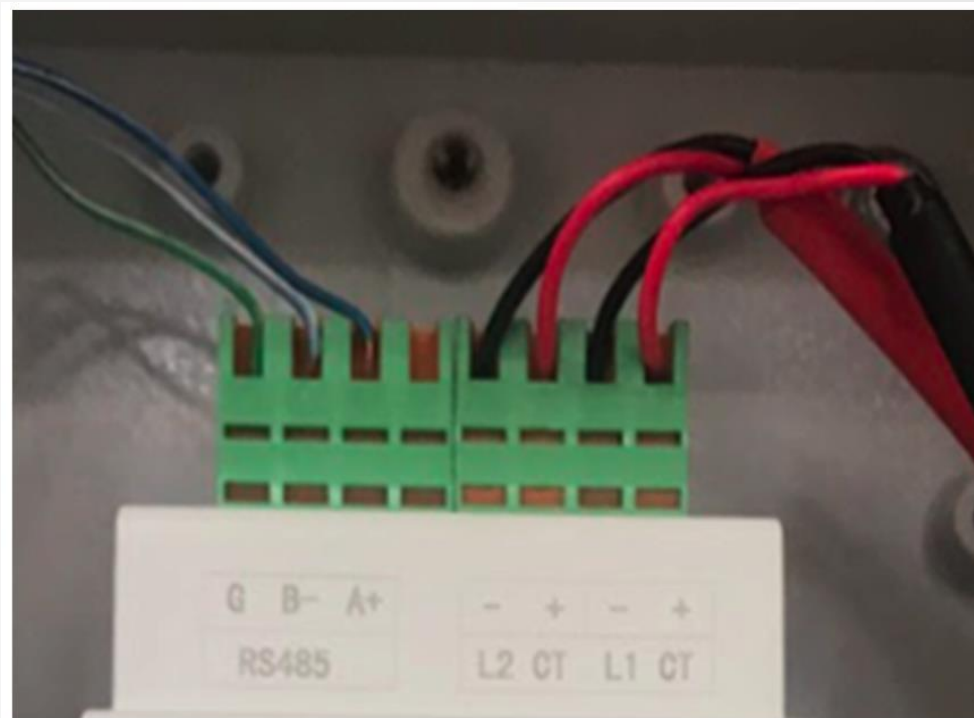
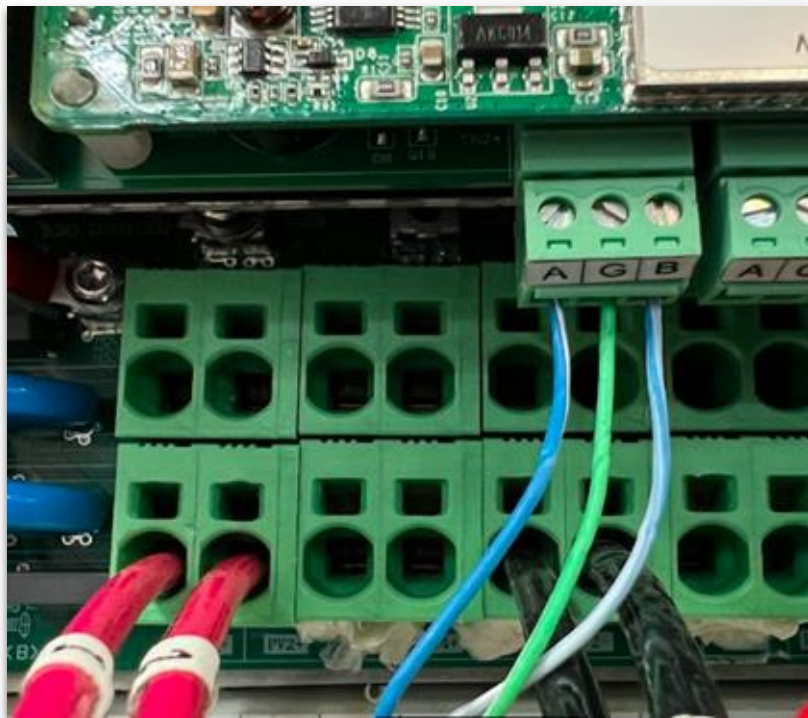

SM-US Terminal	X	A+	G	B-
Connector PIN	X	1	2	3
RS485 terminal inside the MIN TL-XH US wire box	X	RS485A1	GND	RS485B1



SYN Partial & Whole Home Backup Box Connection



Backup Switch for Whole Home System--- SYN-US Connection

Leading Features

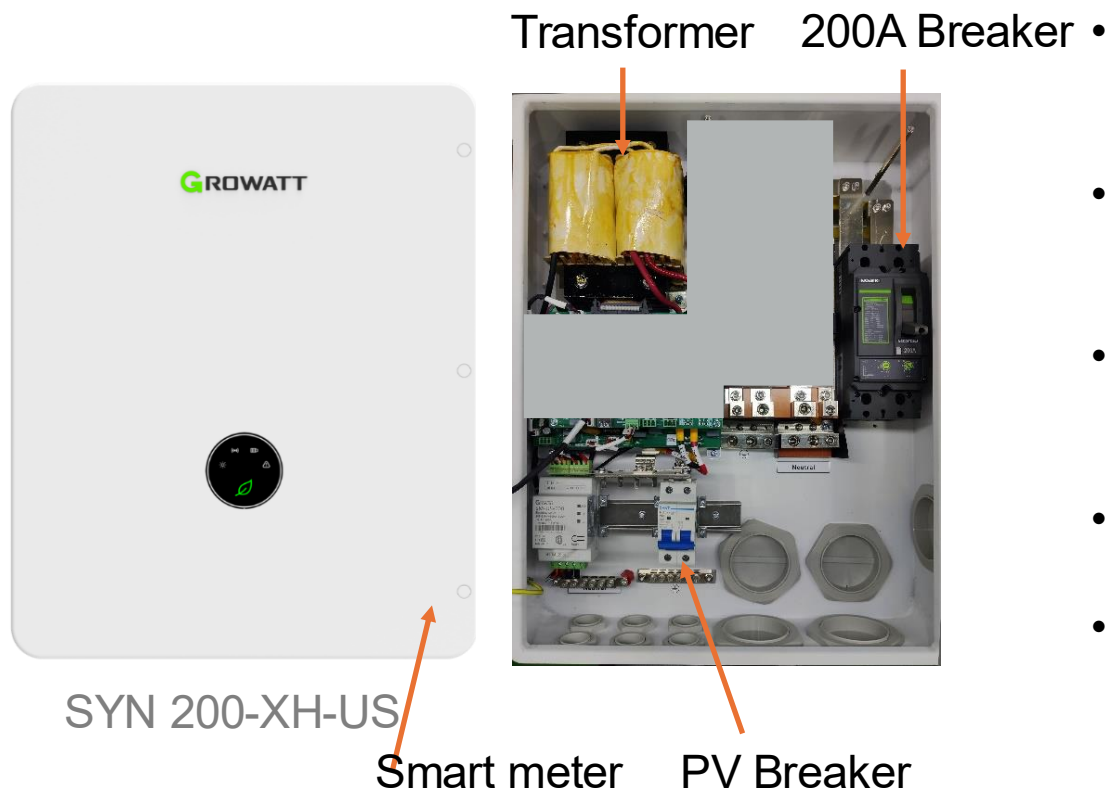

- Easy to operate, integrated 200A circuit breaker on the grid side, no need for external circuit breakers.
- Integrated split-phase transformer, support 120V/240V split-phase output.
- Internal integrated generator, with remote wake-up and intelligent switch function.
- IP65 protection level.
- Certifications:UL1741.

SYN200TL-XH-US Operation Mode

On Grid Mode

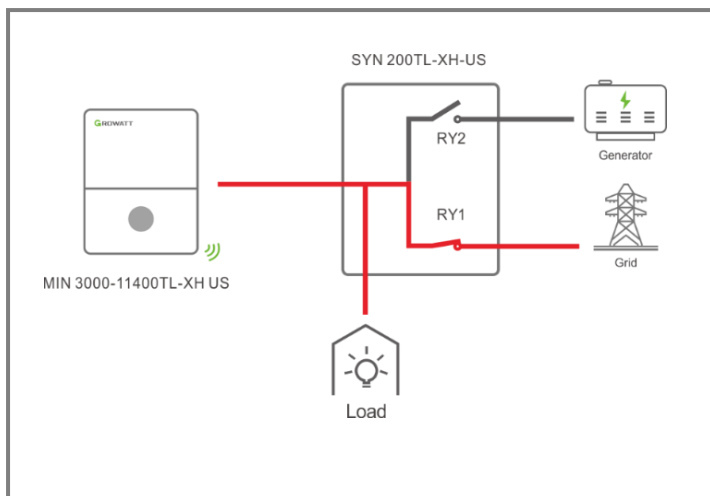

When the grid is normal and communication normal, the grid-side relay RY1 switch on and RY2 disconnected. At this time, the load is powered by the grid, and the inverter is connected to grid.

Off Grid Mode

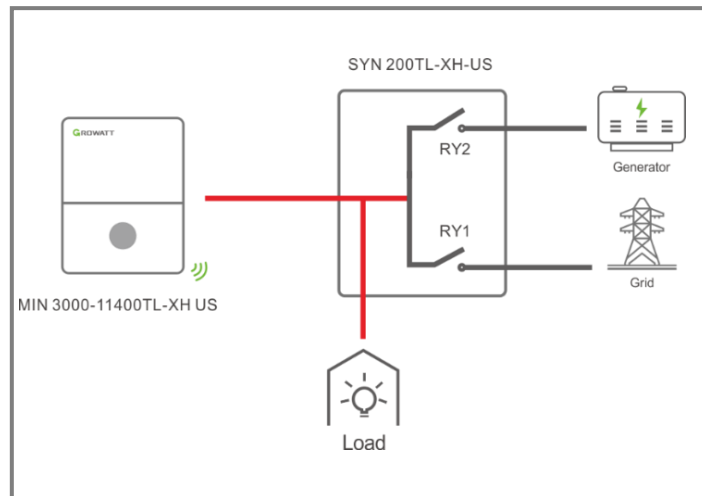

Grid outage, SYN 200-XH-US detects grid abnormal, disconnect relay RY1, system switches to off-grid working mode, load is powered by the inverter, and relays RY1/RY2 are both disconnected.

Generator Working Mode*

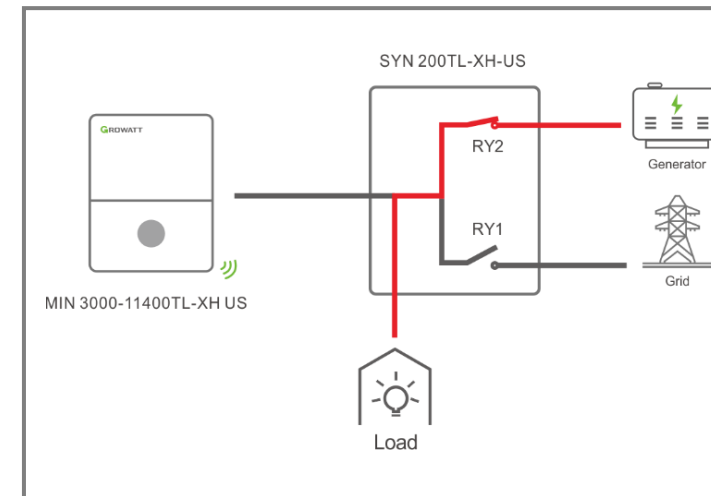

When grid abnormal, no sufficient PV and battery over-discharged, the system switches to the generator working mode, SYN 200-XH-US start up the generator, RY2 switch on, load is powered by the generator. Meanwhile, the inverter is in standby state, PV charges battery if have.

*Generator Working Mode ETA Q4 2024

SYN200TL-XH-US Terminals

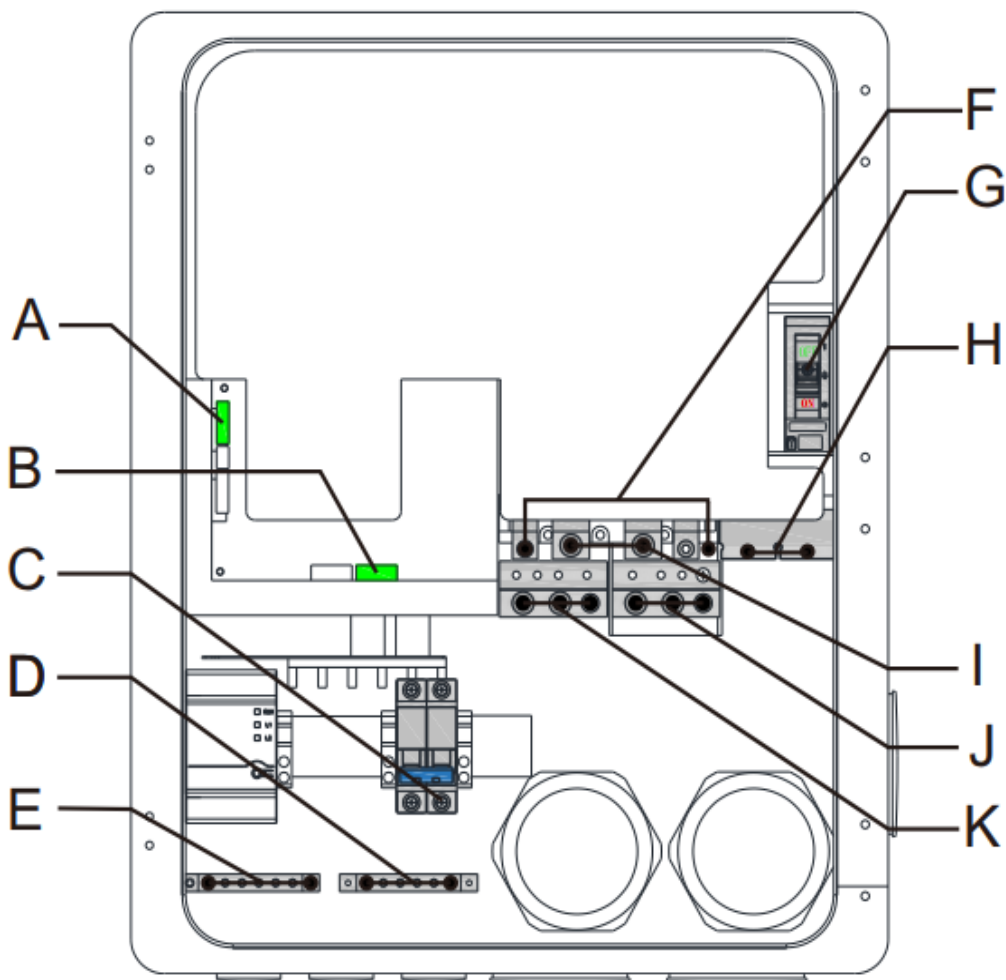

No.	Name	No.	Name
A	Inverter communication Terminals	G	Grid switch
B	Generator communication Terminals	H	Grid wiring port
C	Inverter wiring Terminals	I	Backup Loads
D	Main Ground Terminals	J	Main Neutral Terminals
E	Main Neutral Terminals	K	Main Ground Terminals
F	Generator wiring Terminals		

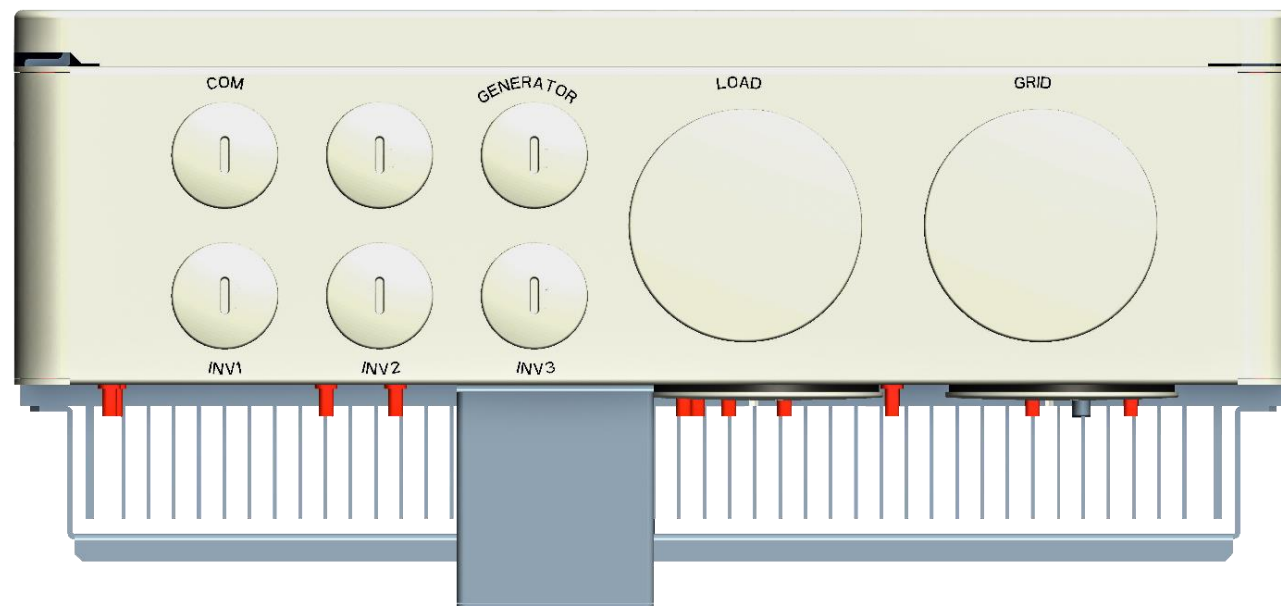

Connecting the SYN 200-XH-US to the Grid

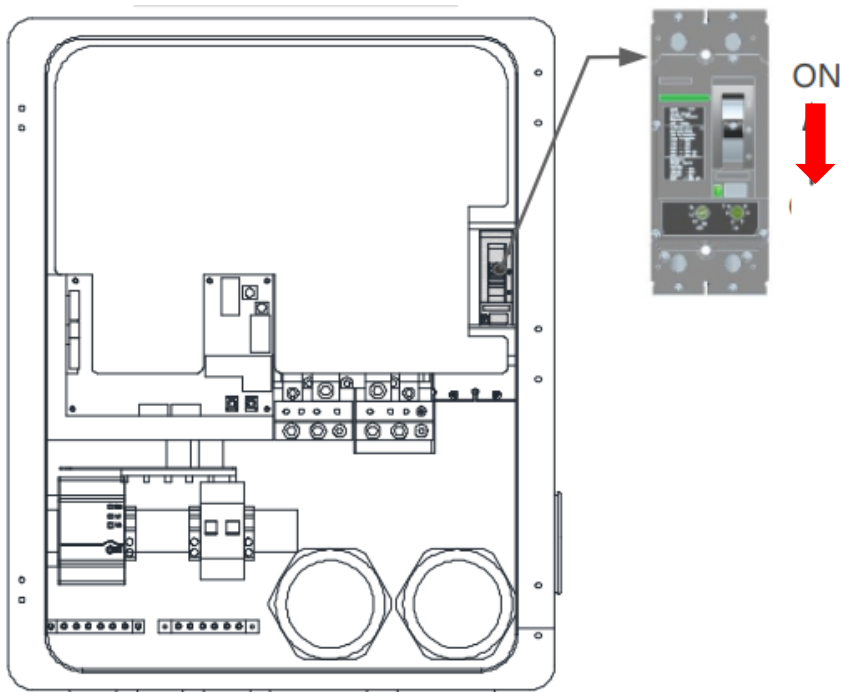

Cables prepared by the customer:

	Use	Type	Size
1	Grounding Conductors (Load/Generator/Inverters)	Yellow-green jacketed or solid bare copper	6~1/0 AWG(Load/Generator) 10~8 AWG(Inverters)
2	AC output conductors (Load/Grid)		0-4/0AWG
3	Generator Input conductors	Multi-color jacket, copper	4~0 AWG
4	Inverter Input conductors		10~6 AWG
5	12V power output conductors	Red and black multi-color copper	16~14 AWG
6	Communication cable	CAT5E suggested	/

1. Release the Allen screws of the upper cover and open the upper cover.
2. Install a conduit of the required diameter into the Grid conduit entry. Use the conduit holder to support the conduit.
3. For versions with circuit breaker. Pull down the main breaker until it shows OFF. Ensure that the main breaker is OFF, as shown

Note:

It is recommended to use two or three polychromatic multi-core copper cables for Grid/Load/ Generator/ Inverter connection. Recommended using yellow-green single multi-core cables for PE connection. Recommended using shielded twisted pair cable for RS485 connection.

Connecting the SYN 200-XH-US to the Grid

2

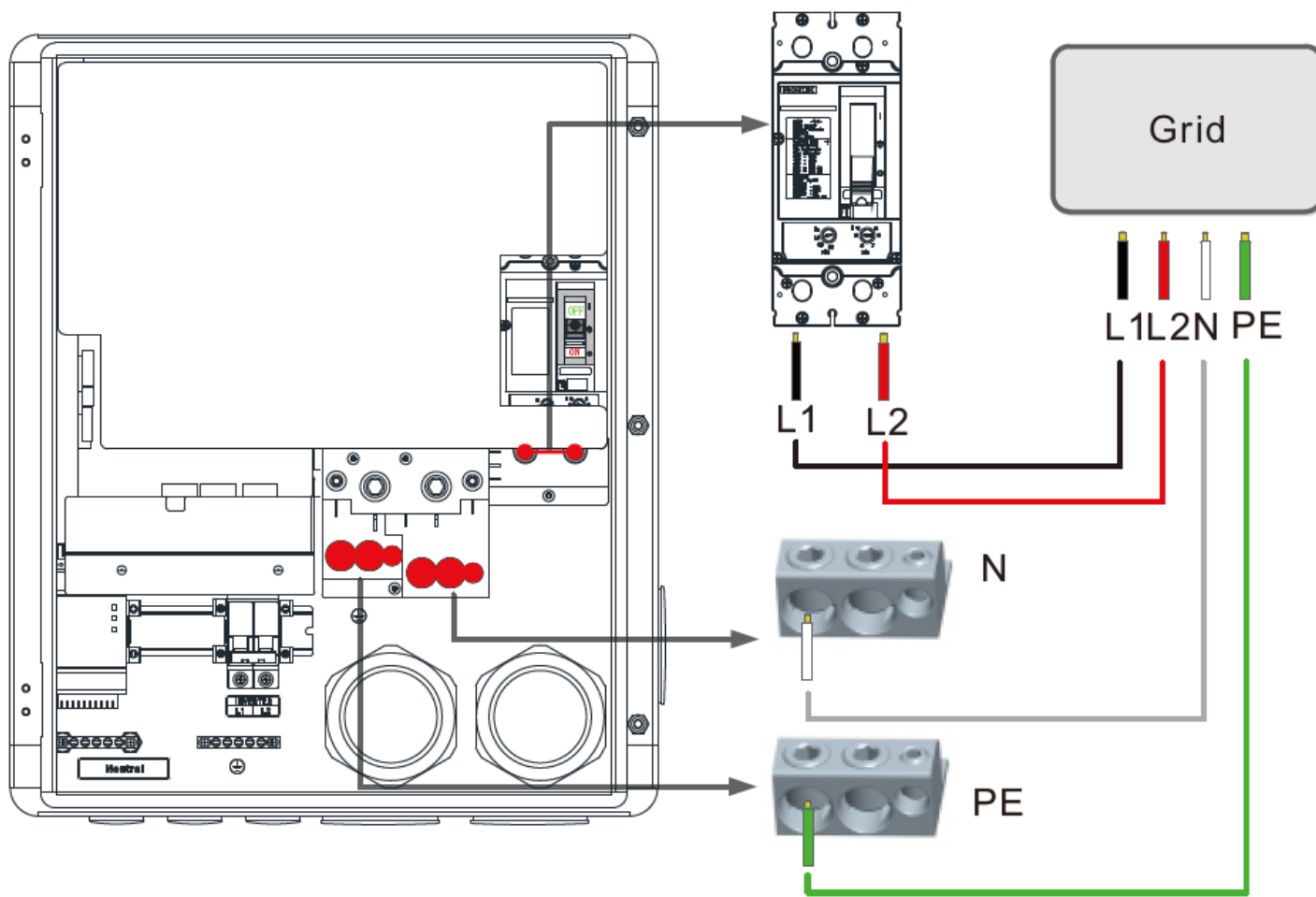

4. Pass the cable from the grid through the grid conduit to the terminals of the circuit breaker.

Tighten the terminal screws with a torque of 310 in*lbs / 35N*m.

5. Connect the neutral and grounding wires to the neutral and grounding terminals.

Tighten the terminal screws with a torque of 310in*lbs / 35N*m.

NOTE: Cable size:
L and N:0-4/0AWG, PE:6~1/0 AWG

Connecting the SYN 200-XH-US to the Load panel

2

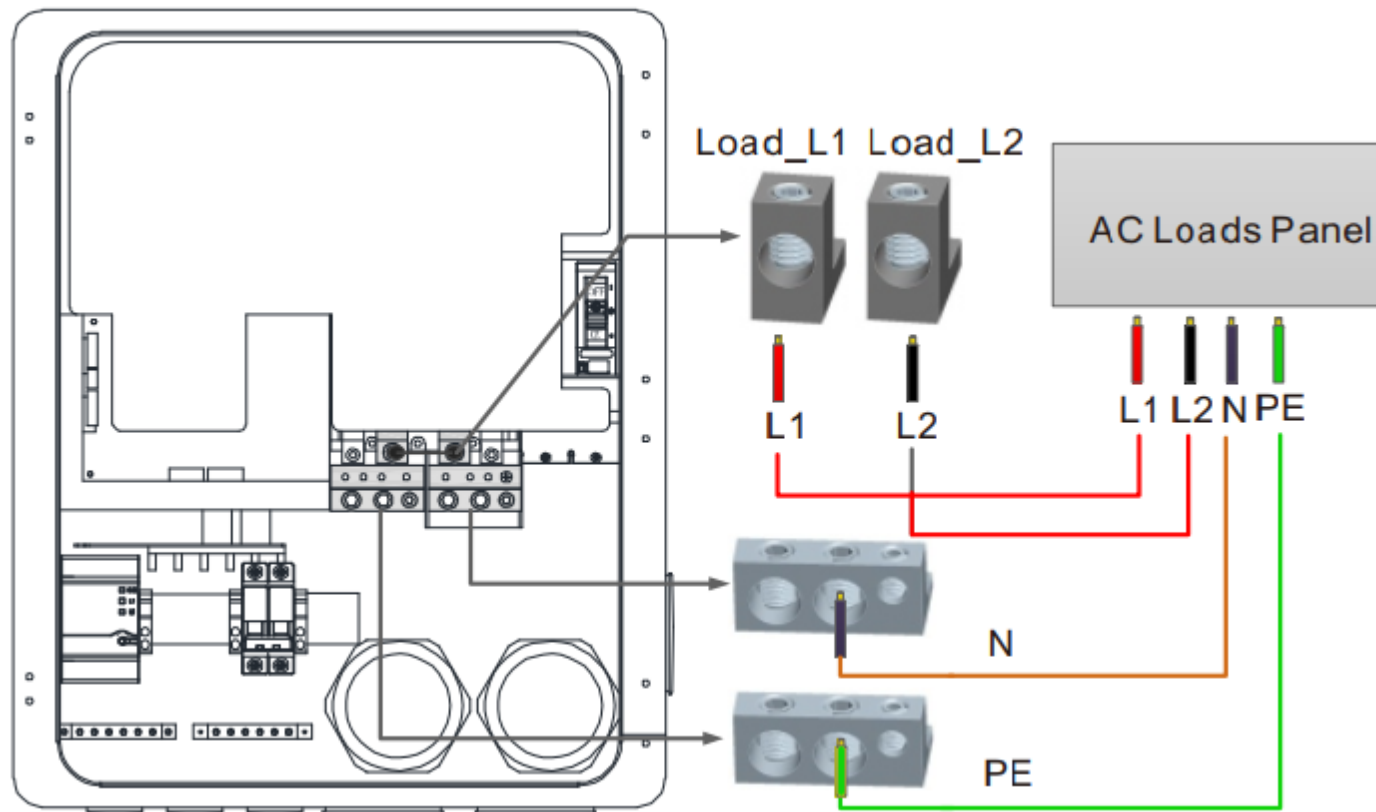

1. Install a conduit of the required diameter into the Loads conduit entry. Use the conduit holder to support the conduit.

2. Pass the cable from the AC Loads panel through the Loads conduit to the Load_L1 and Load_L2 terminals of the SYN 200-XH-US.

Tighten the terminal screws with a torque of 310in*lbs / 35N*m.

3. Connect the neutral and grounding wires to the neutral and grounding terminals.

Tighten the terminal screws with a torque of 310in*lbs / 35N*m, as shown on the right.

NOTE: Cable size:

L and N:0-4/0AWG, PE:6~1/0 AWG

Connecting the SYN 200-XH-US to the Inverter

1. Insert the cable into MIN TL-XH-US inverter RS485 connector(3 pin) and power connector(2 pin) ,as shown in follow figures.
2. Insert the cable into SYN 200-XH-US RS485 connector(CN8) and power connector(CN9) ,as described in follow figures.
3. Connect the cable from MIN TL-XH-US inverter to SYN 200-XH-US.

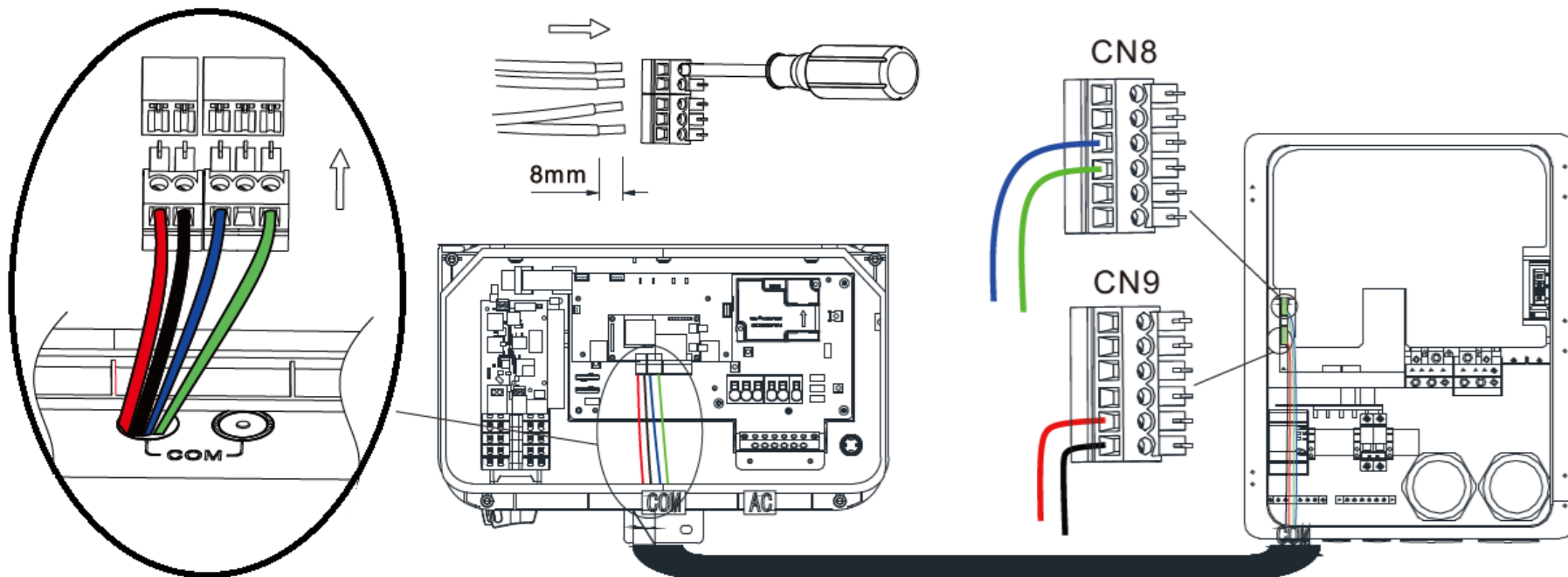

Power and Communication connection between SYN 200-XH-US and Inverter
 (Cable requirement: Shielded CAT5E suggested)

Connecting the SYN 200-XH-US to the Inverter

Installation inverter AC power cables

1. Install a conduit of the required diameter into the INV conduit entry. Use the conduit holder to support the conduit.
2. Pass the cable through the INV conduit.
3. Connect the neutral and grounding cables to the corresponding neutral and grounding terminals. Tighten the terminal screws with a torque of 18 in*lbs / 2 N*m.
4. Connect the GRID L1 and GRID L2 terminal of the MIN TL-XHUS inverter to the INV Breaker terminal of SYN 200-XH-US. Tighten the terminal screws with a torque of 18 in*lbs / 2 N*m.

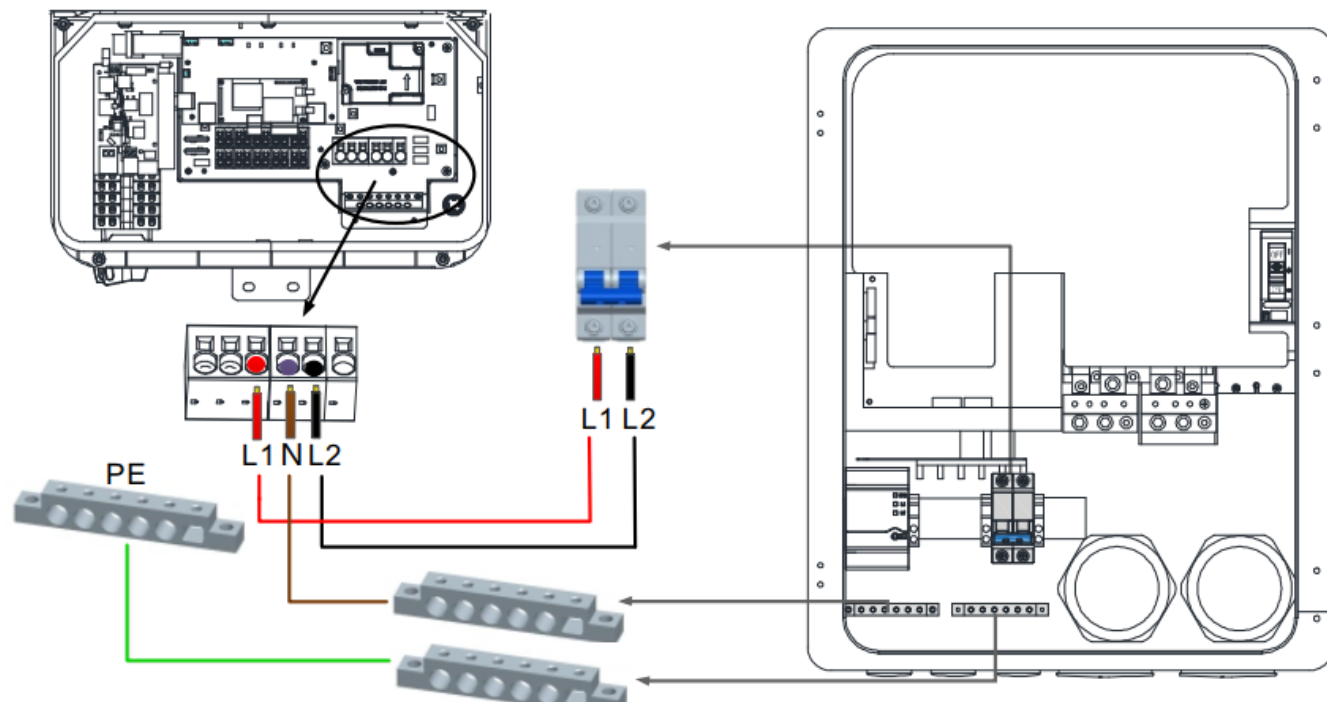

Power cable connection between SYN 200-XH-US and Inverter
(Cable size: L and N:6-5 AWG, PE:6~1/0 AWG)

Connecting the SYN 200-XH-US to Generator *

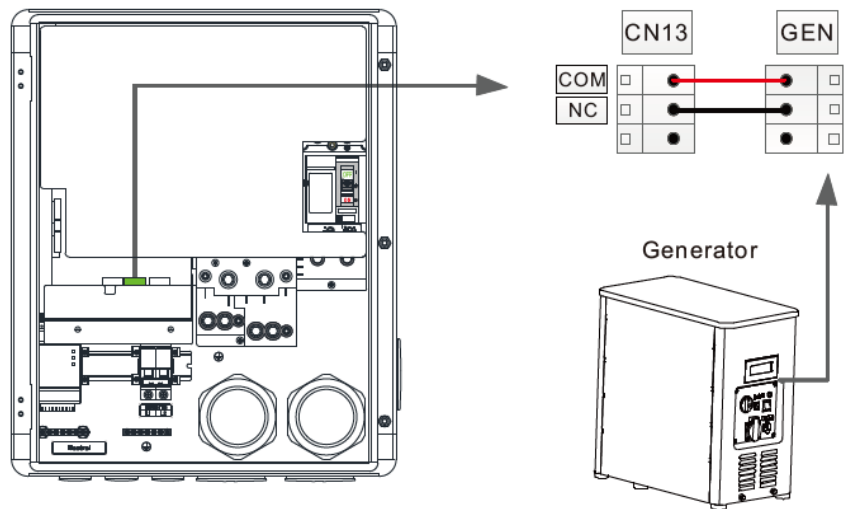

Communication connection between SYN 200-XH-US and Generator

⚠ Note:

1. The COM/NC signal of CN13 is the remote control switch signal of the generator.
2. The above only shows the wiring method of the generator with 2-wire start mode. For other types of generators, please refer to the generator wiring guide.

1, Communication connection between SYN 200-XH-US and Generator
(Cable requirement: Shielded CAT5E suggested)

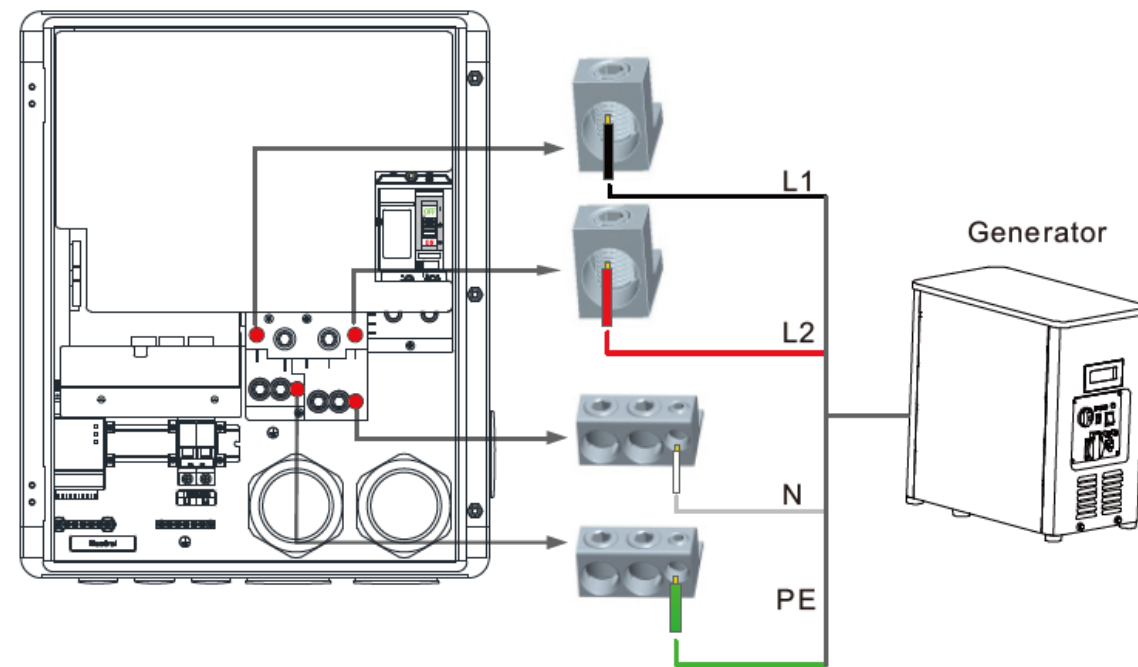

Connection to the Generator

2, Power cable connection between SYN 200-XH-US and Generator
(Cable size: L and N:4-0 AWG, PE:6~1/0 AWG)

*Generator Working Mode ETA Q4 2024

Manual Bypass Operation / Bonding Jumper

In case of the SYN 200-XH-US fault. In order to ensure household electricity, you can manually switch to the mains bypass state by performing the following operations.

1. Shutdown the entire system, please refer to section SYN quick guide 5.2.
2. Insert the 3-pin terminal with the short wire into the 3-pin interface of the SYN 200-XH-US, as shown in the right figure1.
3. Make sure that the AC circuit breaker of the grid is disconnected, and manually rotate the white switch counterclockwise to the "OFF" position, as shown in the right figure2.
4. Power up the entire system, please refer to SYN Quick Guide section 5.1.

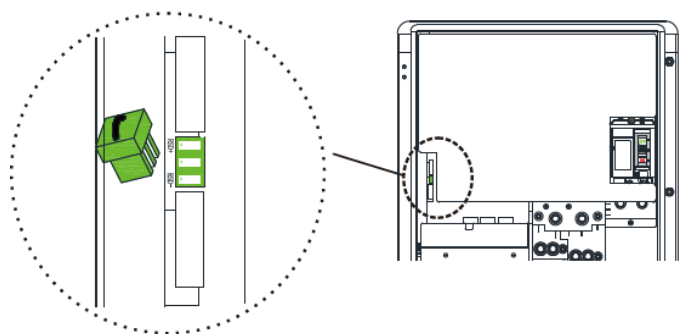

Figure1

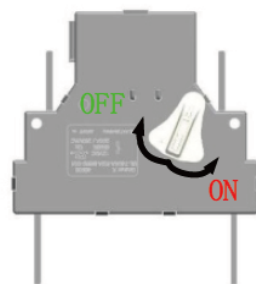
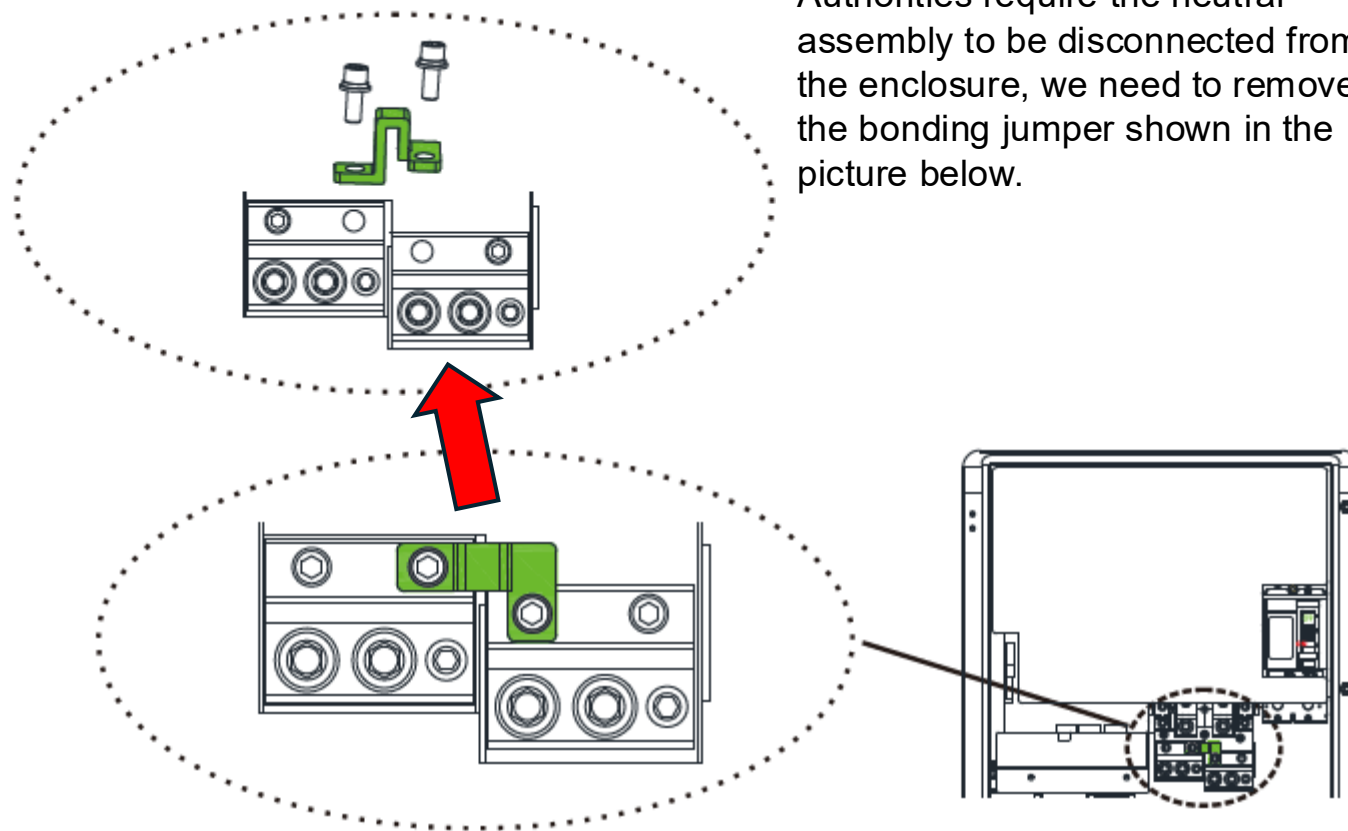

Figure2



Note: Where Electrical Inspection Authorities require the neutral assembly to be disconnected from the enclosure, we need to remove the bonding jumper shown in the picture below.

*Generator Working Mode ETA Q4 2024

APX HV Residential Battery Installation



APX Residential Battery Installation

Environment requirements



Max. +50°C (+122°F) Min. -10°C (+14°F) RH. 5%~95%



M8	2 Nm (17.6inlbs)	M6	2 Nm (17.6inlbs)
		M4	2 Nm (17.6inlbs)
		M3	1 Nm (8.8inlbs)

 Battery is heavy, handle with care.

 Internal arcing risk, do not open the module.

 Keep away from heat and have a fire extinguisher ready during install.

Installation environment requirement

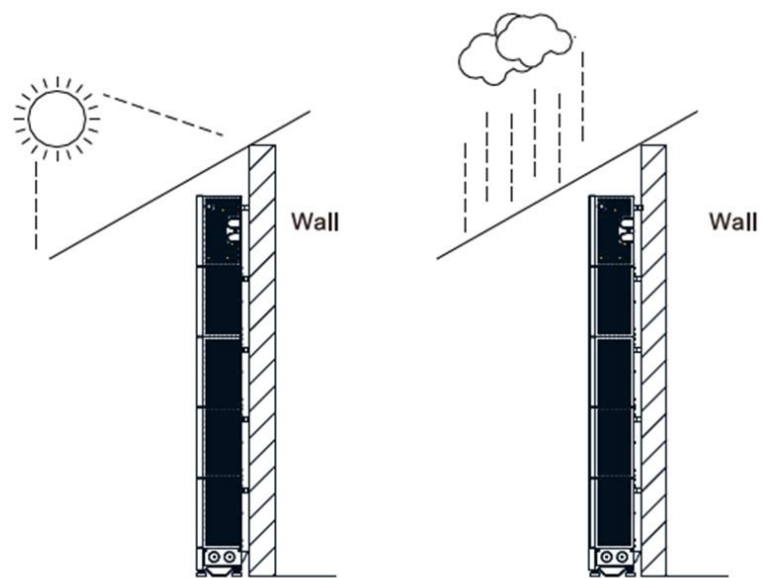

Note: When installed outdoors, build a sun/rain shelter to protect the battery system from sunlight and rain.

APX Residential Battery Installation

3. Floor-mounted installation

3-1 Installation location requirements

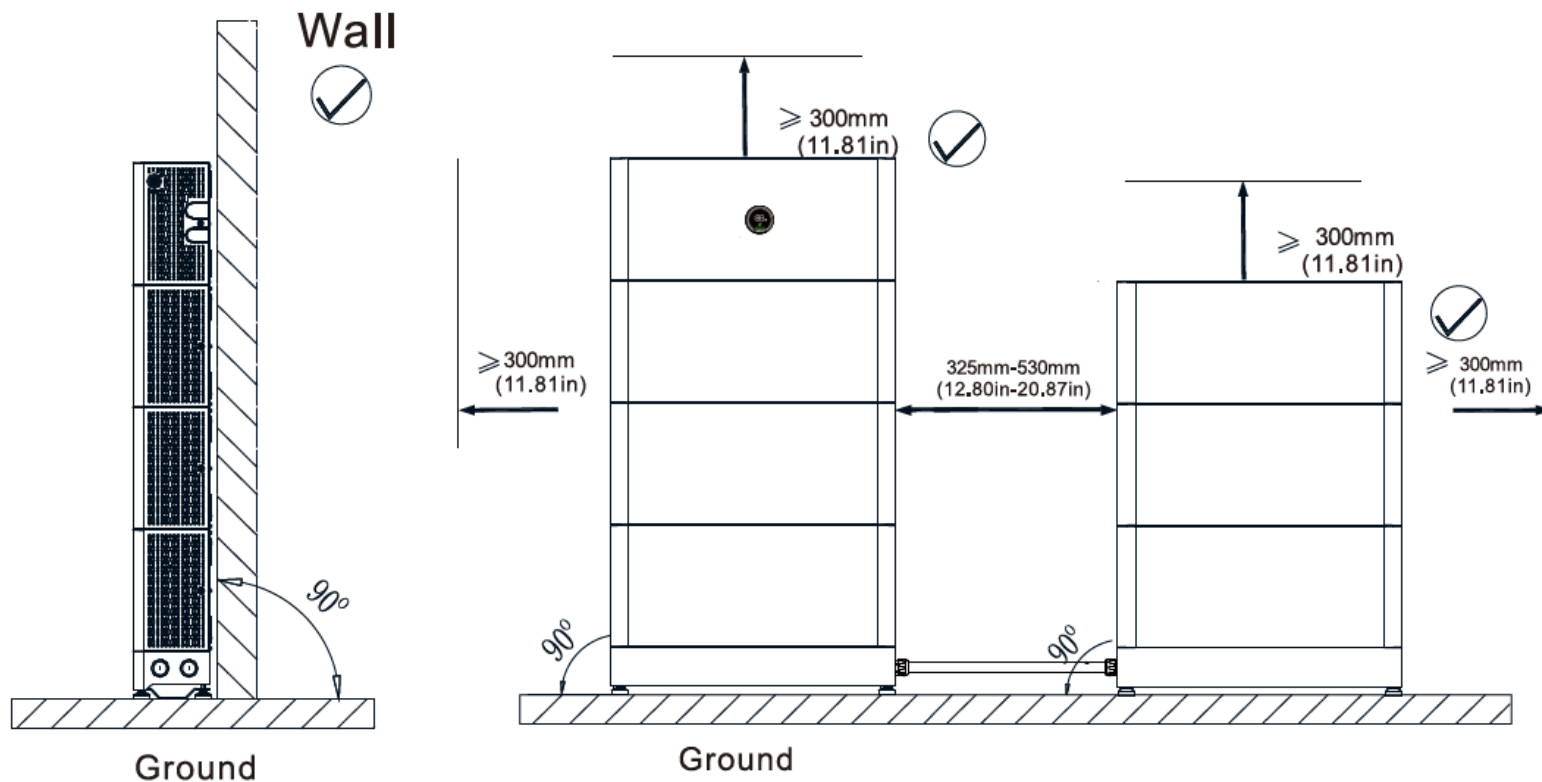

Note: For the floor-mounted installation with the base, a maximum of six battery modules can be configured. If the number of the battery modules to be installed is greater than four, you are advised to install them in 2 columns.

APX Residential Battery Installation

4. Wall-mounted installation

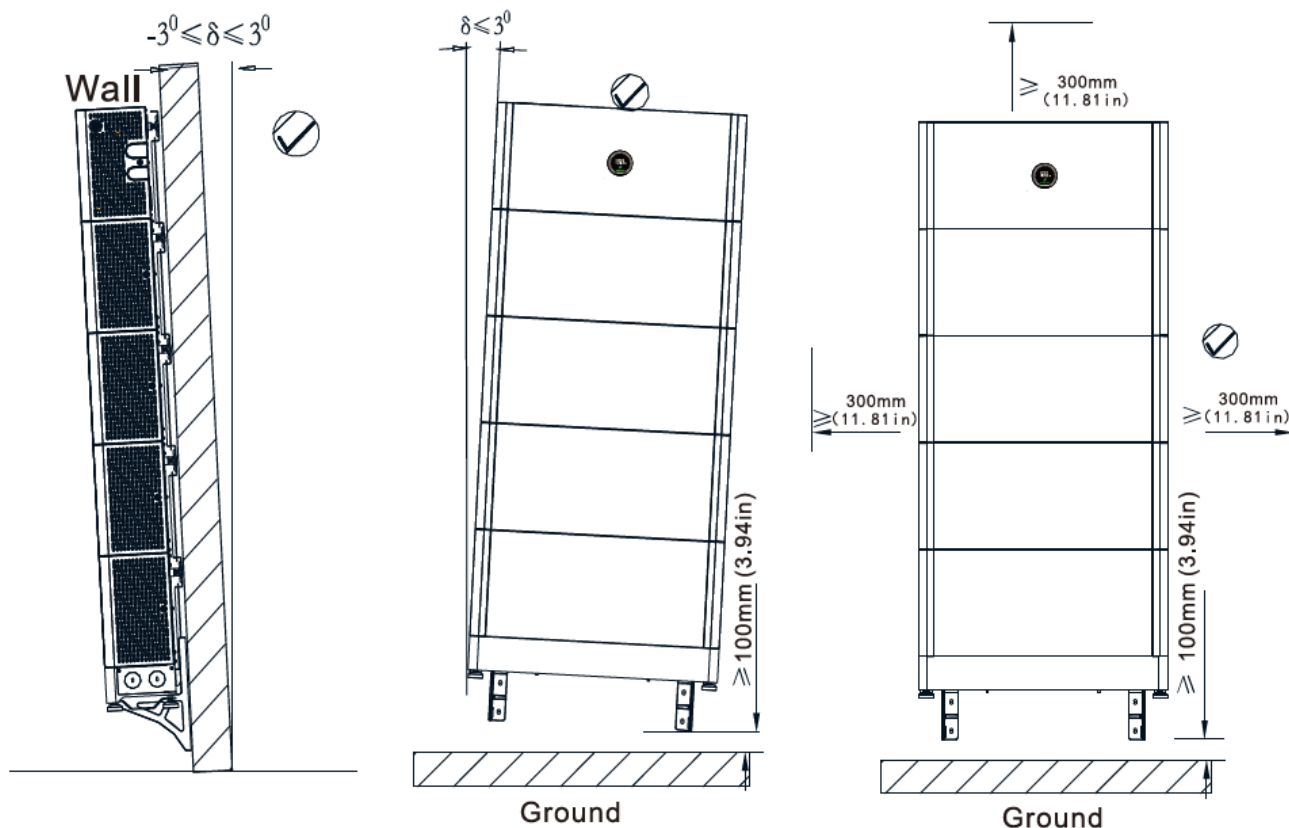

Note: When mounted on the wall, a maximum of four battery modules can be stacked. Please ensure that the load-bearing capacity of the wall exceeds 280 kg (617.29 lbs).

1 Installing the wall brackets



- 1 Stick the paper template for drilling holes onto the wall and keep it level. Please select the appropriate installation dimensions (12 in, 16 in, 20 in or 24 in), and mark the hole positions using a marker
- 2 Fix the mounting bracket to the wall using the M8*95 screws

2 Installing the base

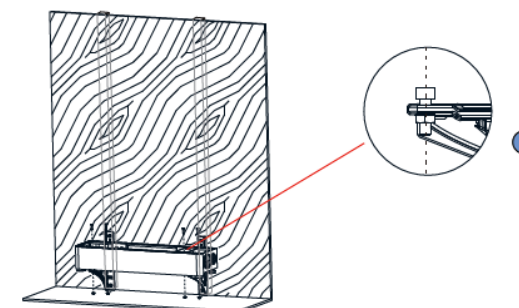

- 1 Place the base onto the mounting bracket
- 2 Insert the four M6*20 screws into the holes on the base, then tighten them with the M6*20 bolts from the bottom

APX Residential Battery Installation

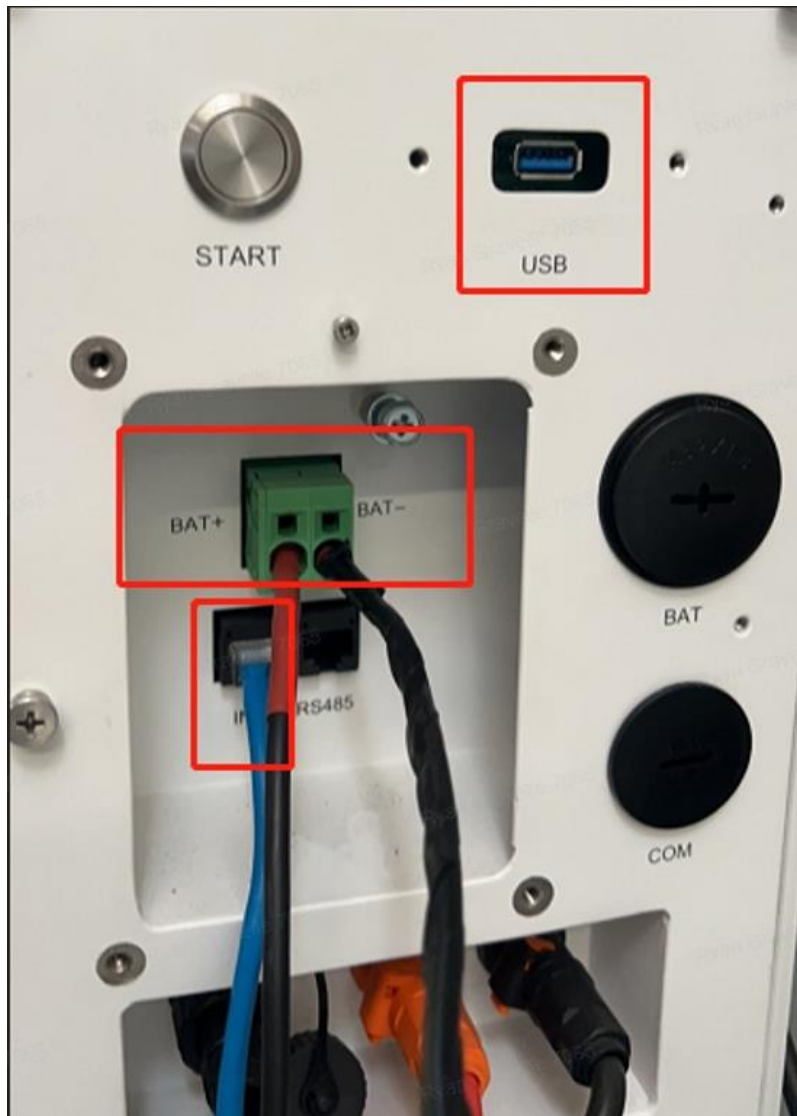

5-1 APX 55042-P0-US terminal & key description

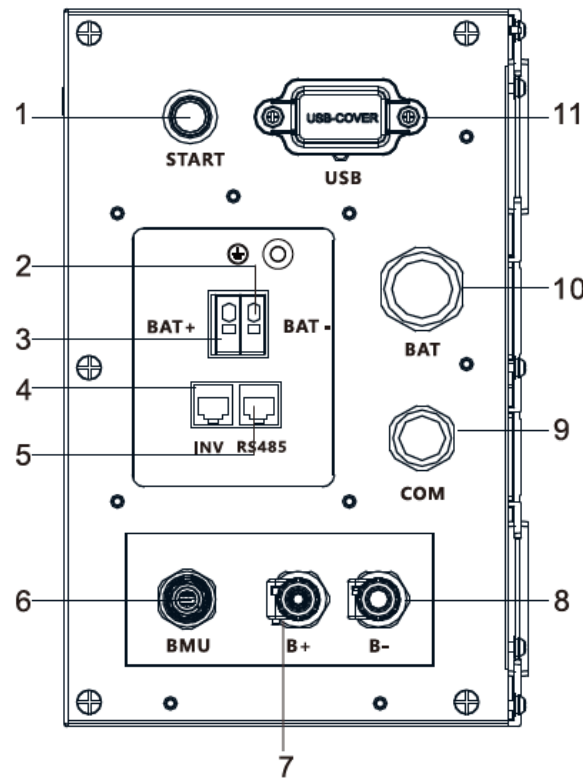

1	START	Start key
2	BAT-	Battery negative terminal connected to the INV
3	BAT+	Battery positive terminal connected to the INV
4	INV	Communication port connected to the INV
5	RS485	Communication port connected to another Power Module(RS485)
6	BMU	Communication port connected to the Battery Module(Link-in)
7	B+	Connect to the positive battery terminal of the Battery Module (B+)
8	B-	Connect to the negative battery terminal of the Battery Module (B-)
9	COM	Inverter communication cable routing hole
10	BAT	Battery positive/negative cable routing hole
11	USB	USB terminal

APX Residential Battery Installation



5-2 APX 5.0P-B1-US terminal description

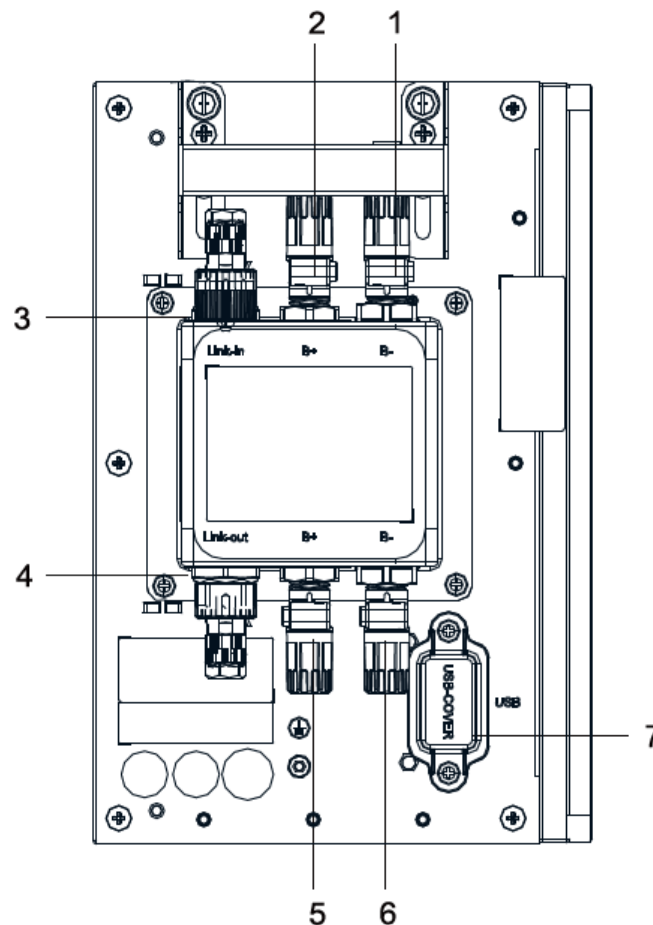

1	B-	Battery negative terminal Connect to another BM (B-) or the PM (B-)
2	B+	Battery positive terminal Connect to another BM (B+) or the PM (B+)
3	Link-in	Communication terminal Connect to another BM (Link-out) or the PM (BMU)
4	Link-out	Communication terminal Connect to another BM (Link-in)
5	B+	Battery positive terminal Connect to another BM (B+)
6	B-	Battery negative terminal Connect to another BM (B-)
7	USB	USB terminal

APX Residential Battery Installation

Battery Capacity Description

The battery supports power and capacity expansion.

One power control module supports a maximum of **six** battery expansion modules.

Each battery module allows for an additional 2.5kW discharge up to 12kW with the MIN TL-XH-US 11.4kW inverter.

Configuration	PM	BM	Max kW	Total kWh
Single	1	1	2.5	5
Single	1	2	5	10
Single	1	3	7.5	15
Single	1	4	10	20
Single	1	5	12	25
Single	1	6	12	30

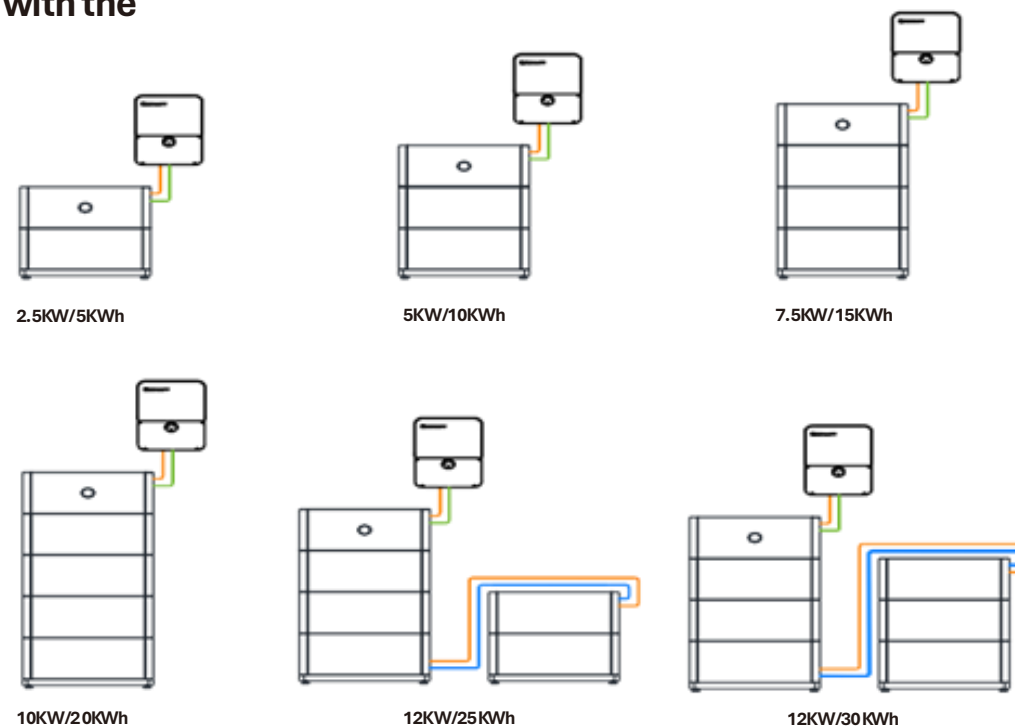

Communication cable
DC input cable
Signal cable

APX Residential Battery Installation

5-4 System wiring diagram

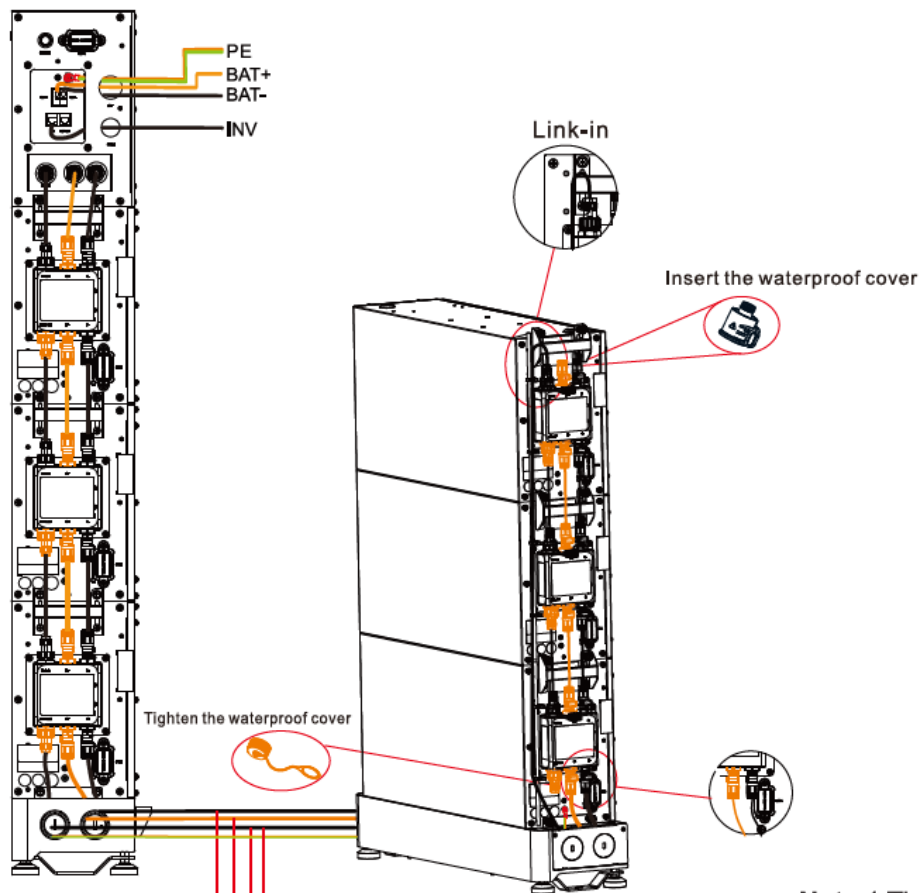

APX 5.0P-B1-US Parallel extension cable

wiring sequence:

Grounding cable ⇨ Communication cable ⇨ Power cable

Power terminal

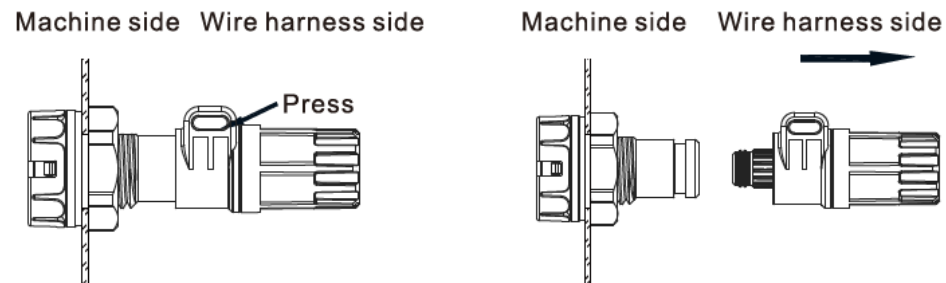

Note: Press the position indicated in the figure above before disconnecting the power terminal.



Note: 1. The RJ45 connector (in orange) of the communication cable is to be connected to the Link-out port (in orange) on the battery module.

2. When wiring the communication cable, remember to tighten the protective cover of the communication cable; otherwise it might undermine the waterproof performance. (Water penetration caused by failure to do so is beyond the scope of warranty.)

APX Residential Battery Installation

5-6 Connecting to the inverter

Note: Please be careful with the components inside the inverter during drilling

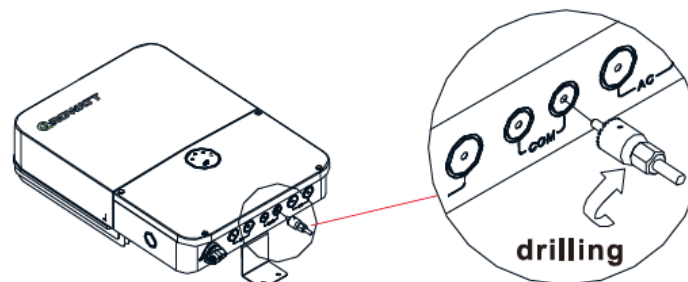
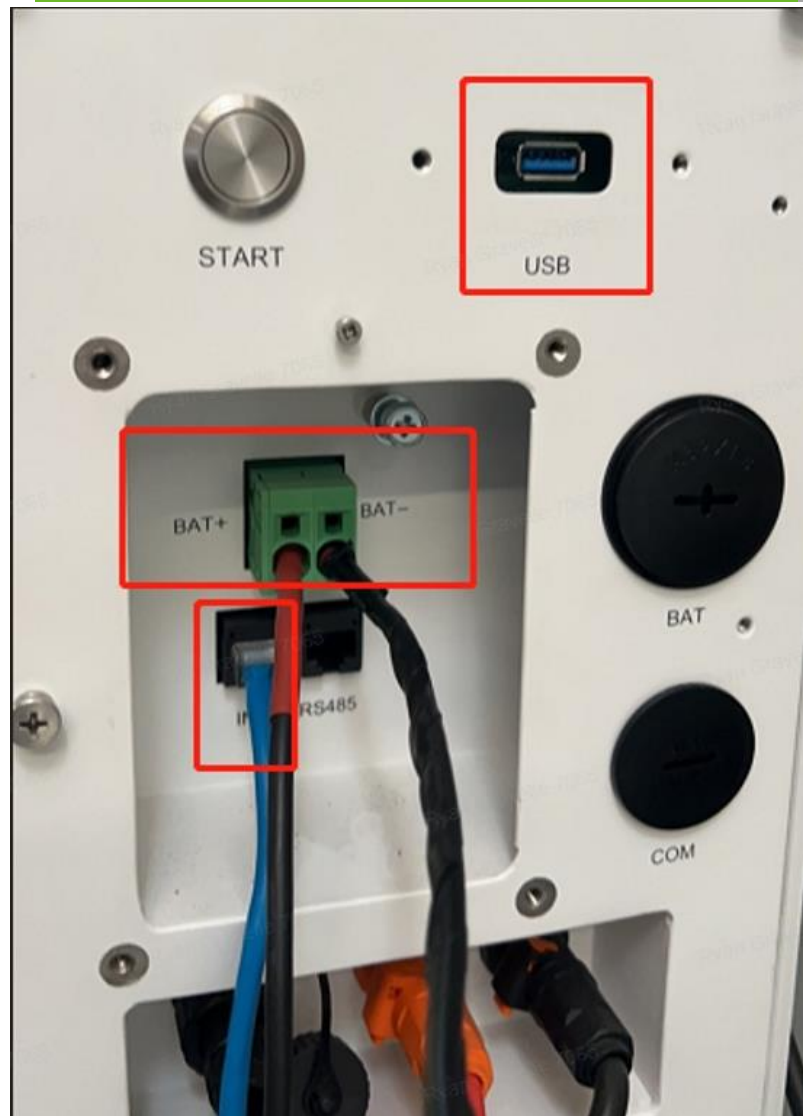

MIN 3-11. 4K TL-XH-US

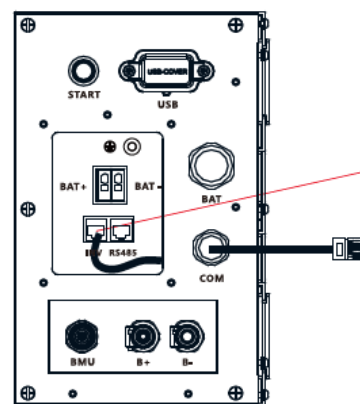
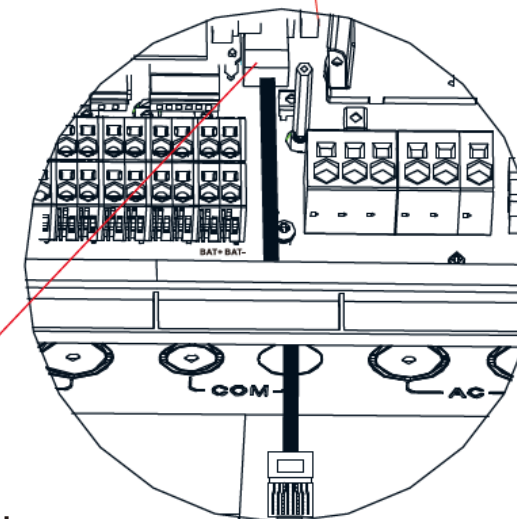
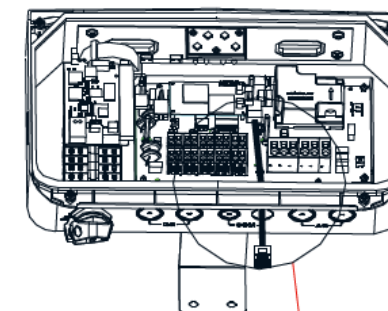

Communication cable

APX Residential Battery Installation

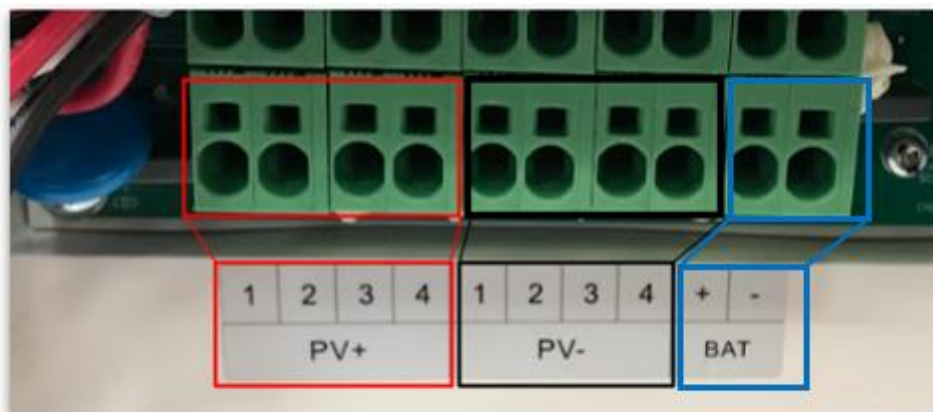

Inverter PV DC terminal blocks

Note: Please be careful with the components inside the inverter during drilling

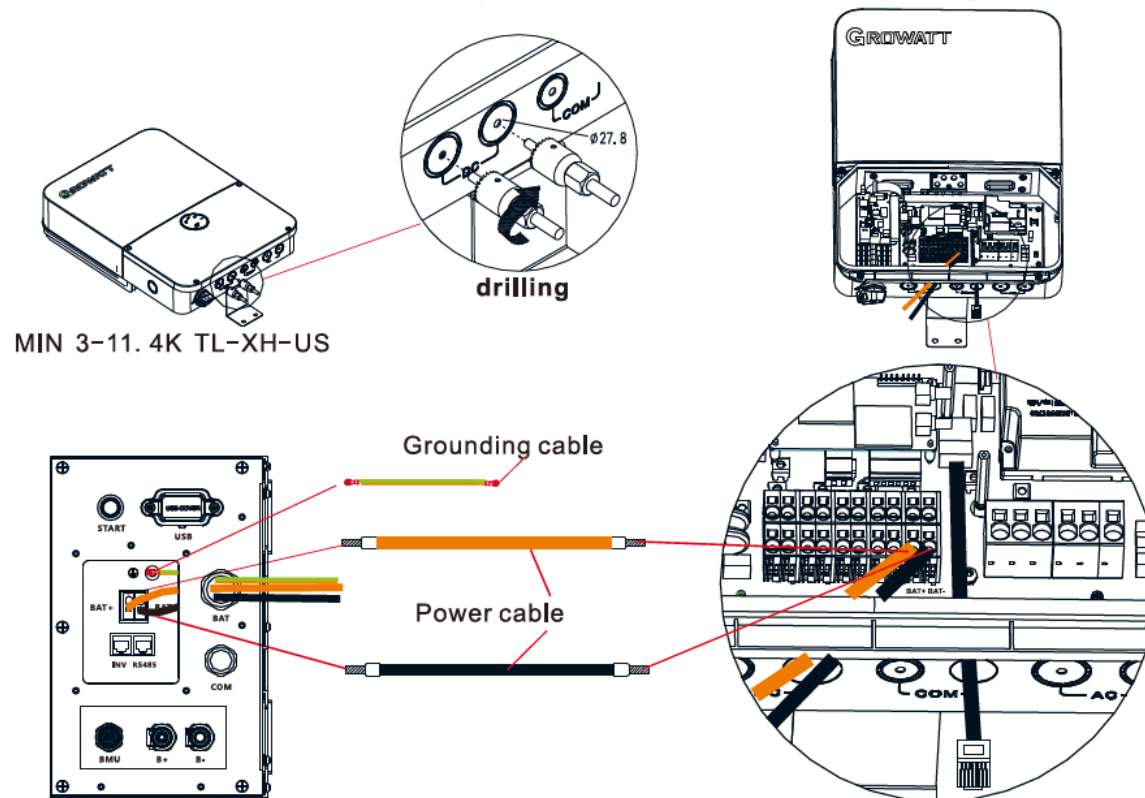

Please prepare the cables listed below before electrical connections (recommended cable length < 3m / 118.1in)

No.	Cable name	Type	Recommended specification
1	Grounding cable	One yellow and green multi-core copper cable	AWG10≤Wire diameter≤AWG8
2	Power cable	Red and black multi-core copper cables	AWG10≤Wire diameter≤AWG8
3	Communication cable	CAT5E suggested	/

APX Residential Battery Installation

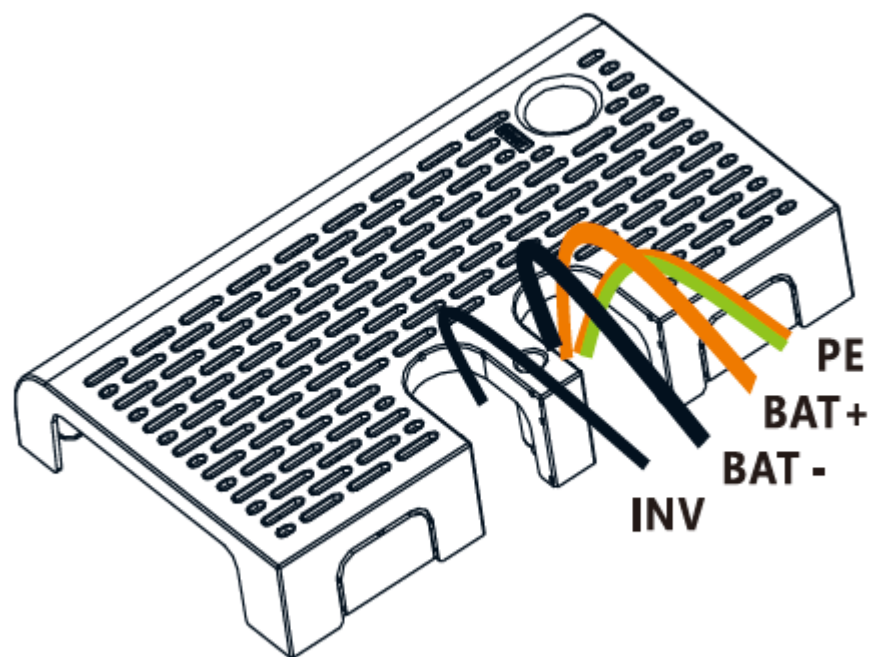
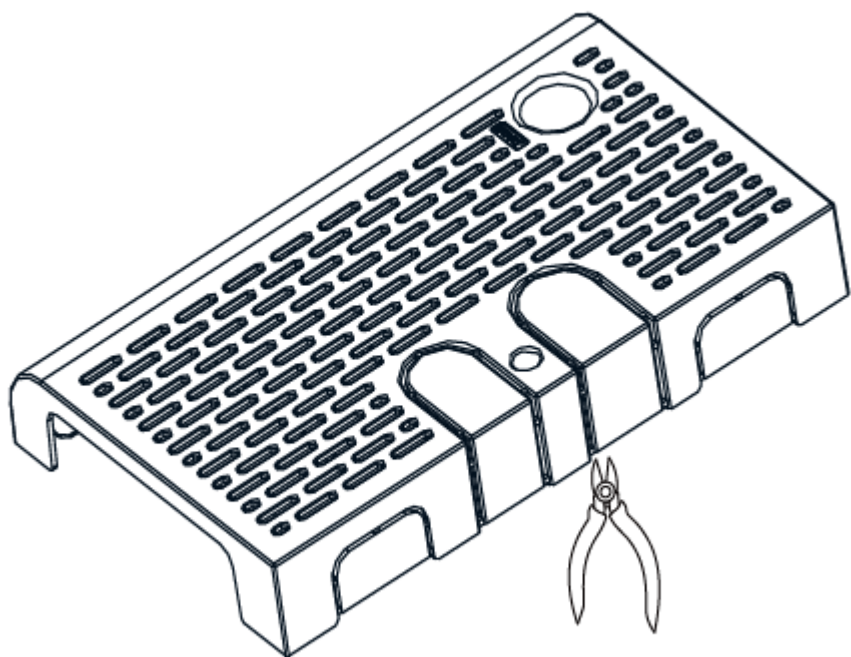

Routing cables out of the cable hole



APX 55042-P0-US Right trim-cover

APX Residential Battery Installation

7. Powering on/off the battery system

<p>Power on</p>	<p>1. Turn on the DC Switch 2. Press the Start key for more than 5S</p>	
<p>Power off</p>	<p>Turn off the DC Switch (wait for over 90S)</p>	

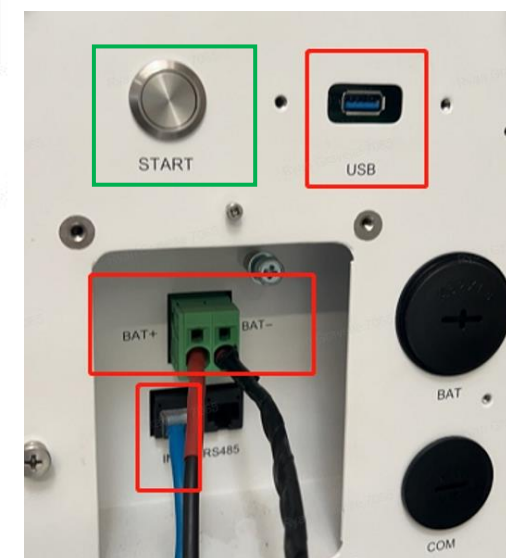
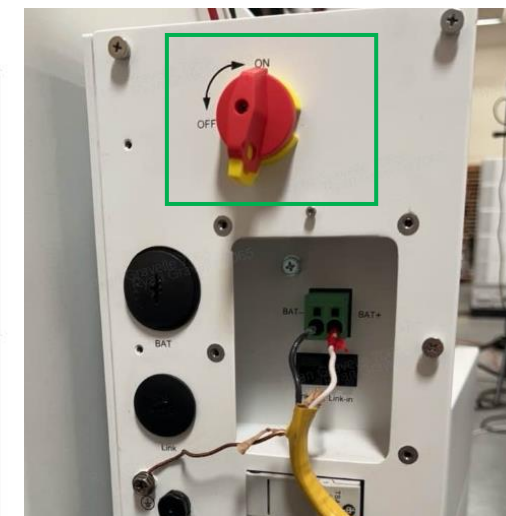

Note: 1. Before performing maintenance and repair work, ensure that the AC circuit breaker, DC switch of the INV, and DC switch of the APX Power module are in the OFF position. **Wait for 15 minutes after the system is powered OFF and make sure that the LOGO (GROWATT) indicator on the APX is off.** Do not perform any operations until the system has completely shut down.

2. The content of this document is continually reviewed and amended, where necessary. Growatt reserves the right to make changes to the material at any time and without notice. Unless otherwise agreed, this document is for quick installation guidance only. All information and suggestions in this document do not constitute a warranty of any kind, express or implied. Growatt reserves all rights for final interpretation.

APX Residential Battery Installation

Installing the trim-cover

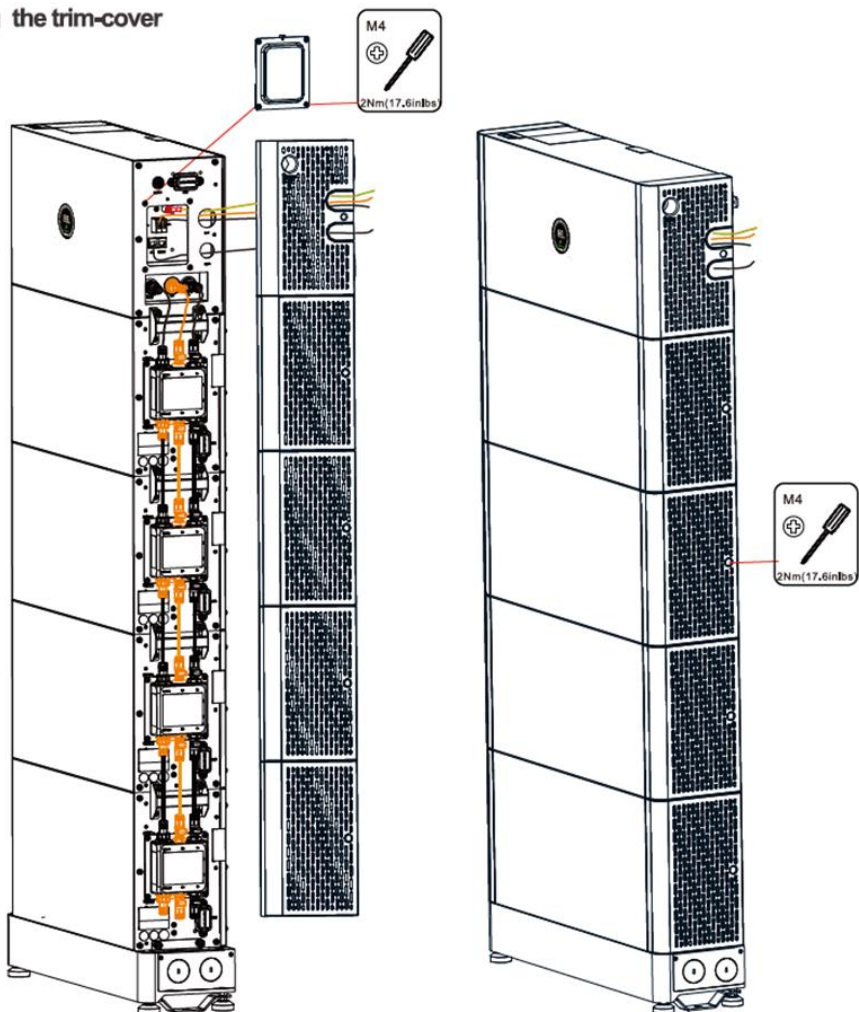

Wire connection sequence:

1. Ground Cable
2. Communication Cable
3. Power Cable

APX Battery Modules inbuilt with module-level optimizer SHALL Be externally paralleled together.

Which means **Battery Module+ connect Battery Module+**
Battery Module- connect Battery Module-

Note: It is not recommended to install a DC circuit breaker between the battery system and the PCS, If you want to install a DC circuit breaker with rated working voltage greater than 1000V and rated working current greater than 63A, do not operate the DC circuit breaker with power on, otherwise the machine may be damaged.

System Startup

Before power on, please make sure all the voltage and current are in the range of specification of hybrid inverter. Otherwise, it will be damage to hybrid inverter.

Follow are the steps of turn on actions:

1. Turn on the switch between Grid and hybrid inverter.
2. Turn on battery and the switch between battery and hybrid inverter.
3. Turn on PV switch. And then turn on switch between PV and hybrid inverter. **Please don't turn on PV switch of inverter under PV voltage, that can damage the inverter.**
4. If need to setup hybrid inverter. Please turn to user manual of hybrid inverter for detail description.
5. The shutdown steps are opposite to the above order.



SPH 10000TL-HU-US



SHENZHEN GROWATT NEW ENERGY CO.,LTD

GROWATT

Residential Whole Home Backup

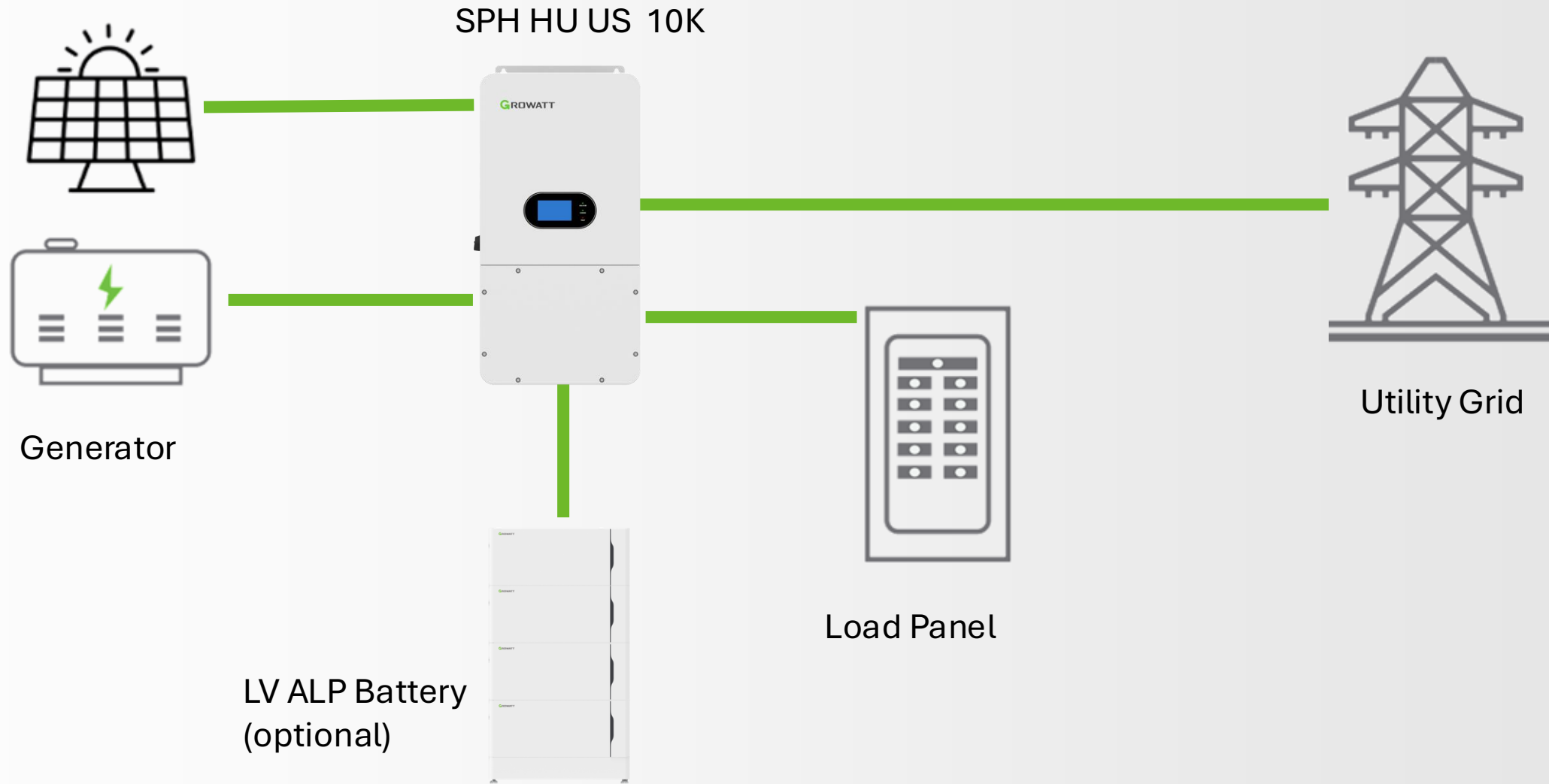

Product Overview-SPH 8000-16000TL-HU-US



SPH 10000TL-HU-US

General

- Output Power:10000W
- Support 120V/208V& 240V split phase output
- UPS <10ms switch to off-grid
- Built in transfer switch
- 3 MPPT'S

Protection

- NEMA 4/IP65 rating. Dustproof & Waterproof
- 10-year product warranty

Leading Features

- Parallel 6 inverters
- Supports Direct Generator Input
- 1.5 DC/AC ratio
- Remote monitoring via WiFi or Ethernet
- Built in LAN, WiFi and 4G
- Interface with low voltage batteries

Compatible Battery



Battery Module
ALP 5.0L-E2-US

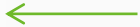

ALP Low Voltage Battery System

- UL9540 certification
- (IP66,NEMA 4X)
- 5.0kWh / Module
- Flexible capacity : 5.0kWh ~ 320kWh
- Excellent safety of cobalt free LiFePO4 battery
- Up to 220A per string, no need for combiner box
- Option for wall mount brackets
- Operating temp. range: -10C to 50C



Supports multiple Operating Modes

- Self-consumption + zero-export mode (requires CTs)
- Battery first
- Peak shaving (requires CTs)
- TOU schedules

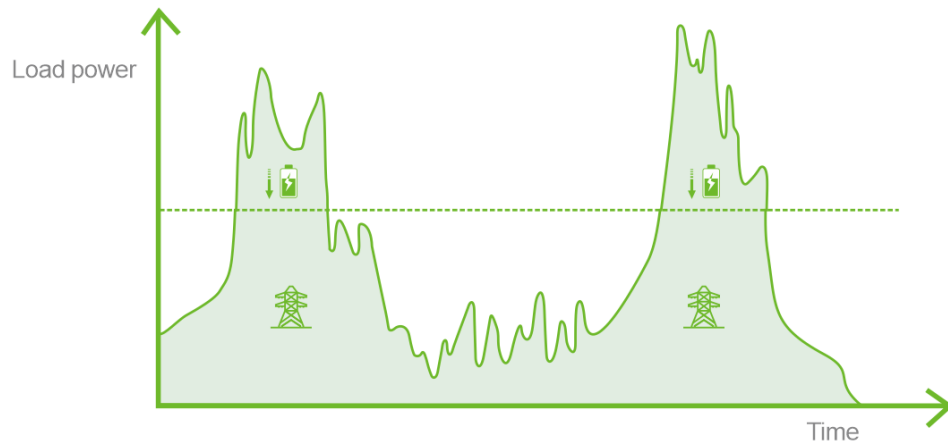

Operating Modes

ON Grid Mode

Self-consumption Mode PV Sell

Zero Export Limit PV Sell

Max Sell Power 10000 W

PV Priority Battery First Load First

Grid Peak Shaving 10000 W Power

1/2

System Work Mode

Time Of Use

Grid Charge	Gen	Time	Power	Battery
<input checked="" type="checkbox"/>	<input type="checkbox"/>	09:00 18:00	10000	<input type="checkbox"/>
<input checked="" type="checkbox"/>	<input type="checkbox"/>	18:00 09:00	10000	<input type="checkbox"/>
<input type="checkbox"/>	<input type="checkbox"/>	00:00 00:00	0	<input type="checkbox"/>
<input type="checkbox"/>	<input type="checkbox"/>	00:00 00:00	0	<input type="checkbox"/>
<input type="checkbox"/>	<input type="checkbox"/>	00:00 00:00	0	<input type="checkbox"/>
<input type="checkbox"/>	<input type="checkbox"/>	00:00 00:00	0	<input type="checkbox"/>

2/2

SPH DC/AC Ratio 1.5

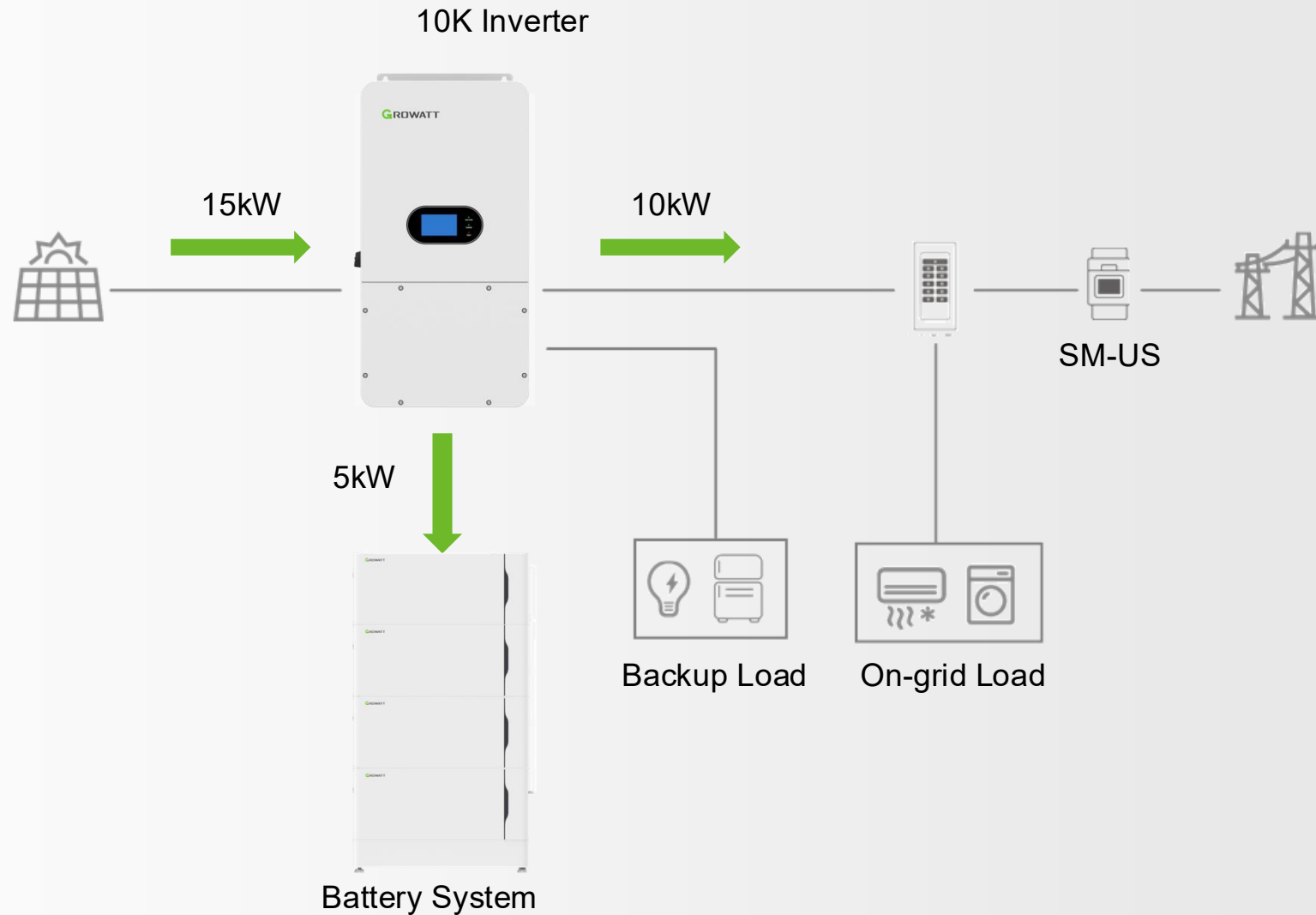

Suitable for commercial applications

SPH 10000TL-HU-US supports up to 6 connected in parallel (120/240 or 120/208) to expand the system power to 60kW

Parallel in 120/208 V three phase

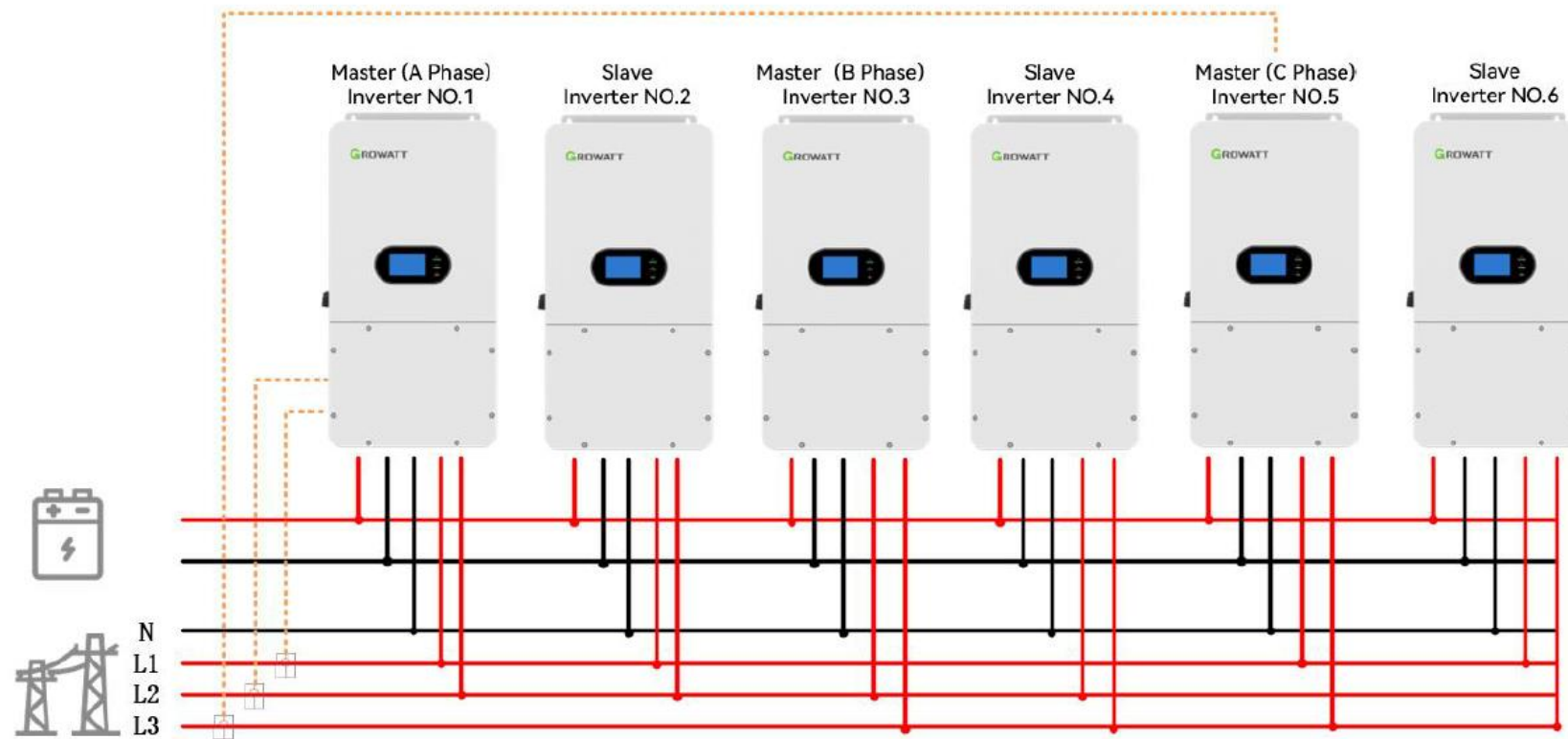

Six inverters in parallel

Load Shedding function

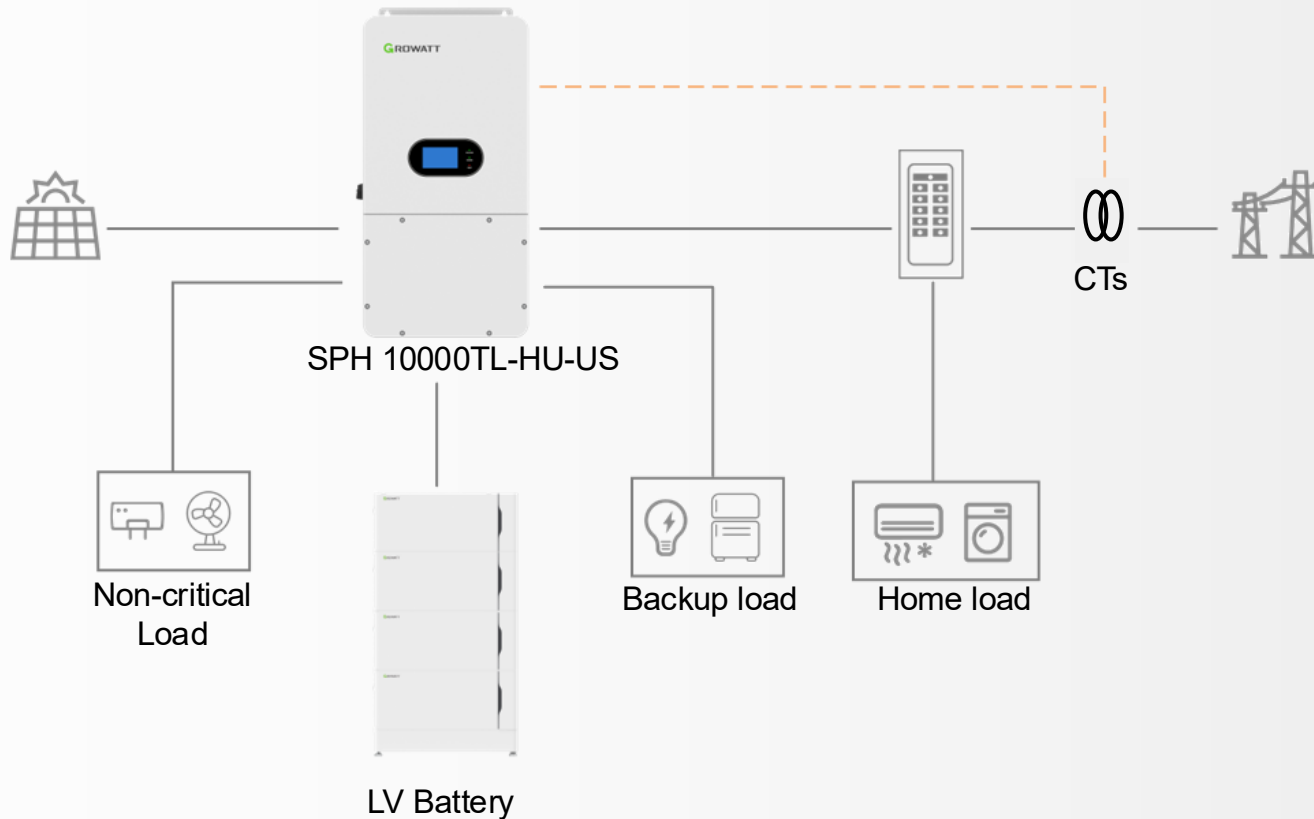

Gen Port is Used for Load Shedding/Smart Load Function

Allows users to prioritize home loads by connecting non-critical loads to the GEN port. The system powers the non-critical loads on and off based on the battery's state of charge (SOC), ensuring optimal energy management.

SPH AC-Coupled Solution

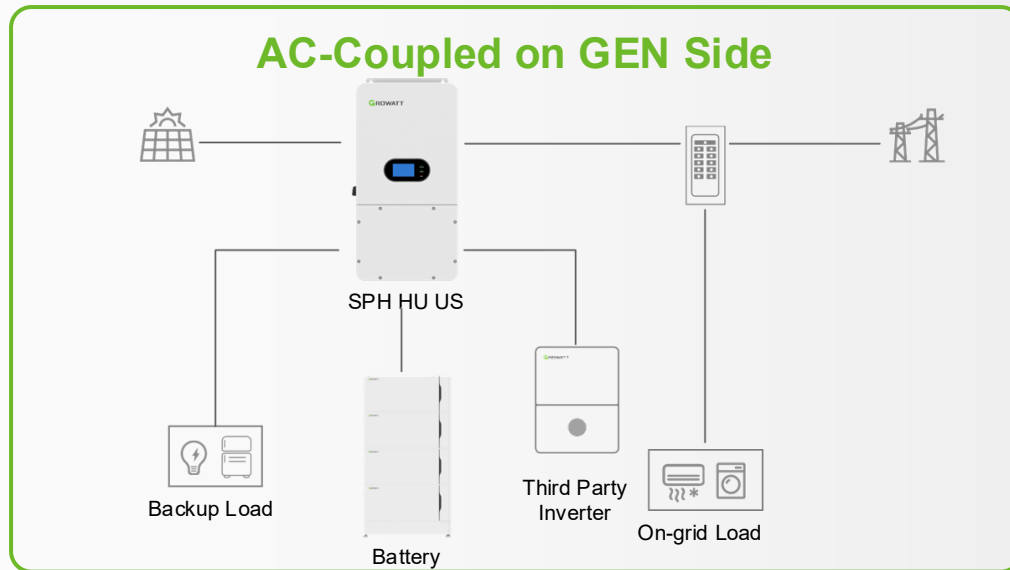

SPH-HU-US AC-Coupled Solutions

The SPH HU US allows easy integration of batteries into existing PV only systems and is perfect for AC retrofitting.

Compatible Battery

Battery Flexibility

In addition to Growatt-branded batteries, the SPH HU US is also compatible with various third-party batteries. Updated list include battery models is available at:

https://us.growatt.com/upload/file/Growatt_Approved_LV_Battery_List.pdf

SACOLAR

TOPBAND
BATTERY

Pytes

PYLONTECH

DYNNESS

EnerSys

RAYSTECH

ZETARA

SOLUNA™



BRIGGS & STRATTON
ENERGY SOLUTIONS

Dual Battery Input Port

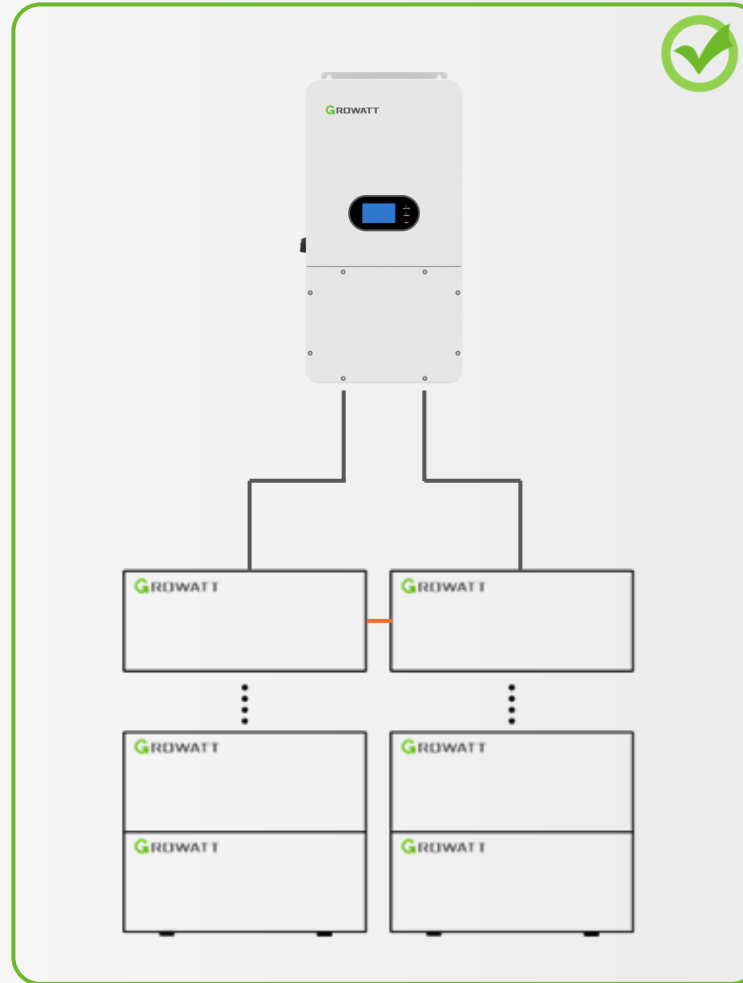
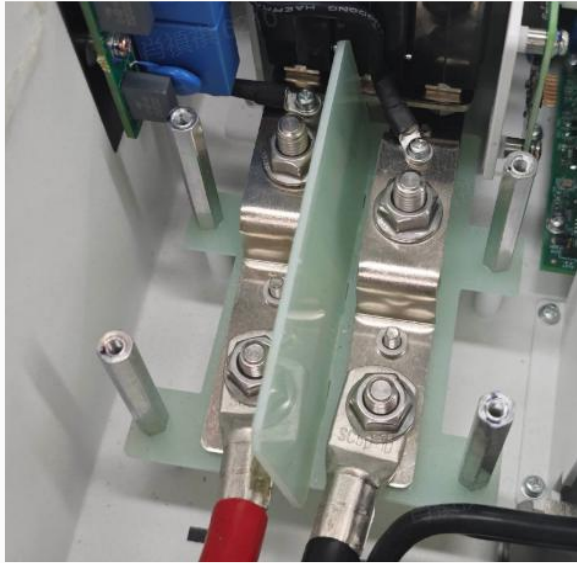

Dual Battery Input Port for Two Cluster of Battery in Parallel

With the dual battery input port, clients can easily expand battery capacity or increase output power. This eliminates the need for an additional battery combiner box, simplifying the installation process and reducing costs

SPH Inverter Installation



Quick Guide / Manuals / White Papers / Powerpoints

US.Growatt.com/support/download

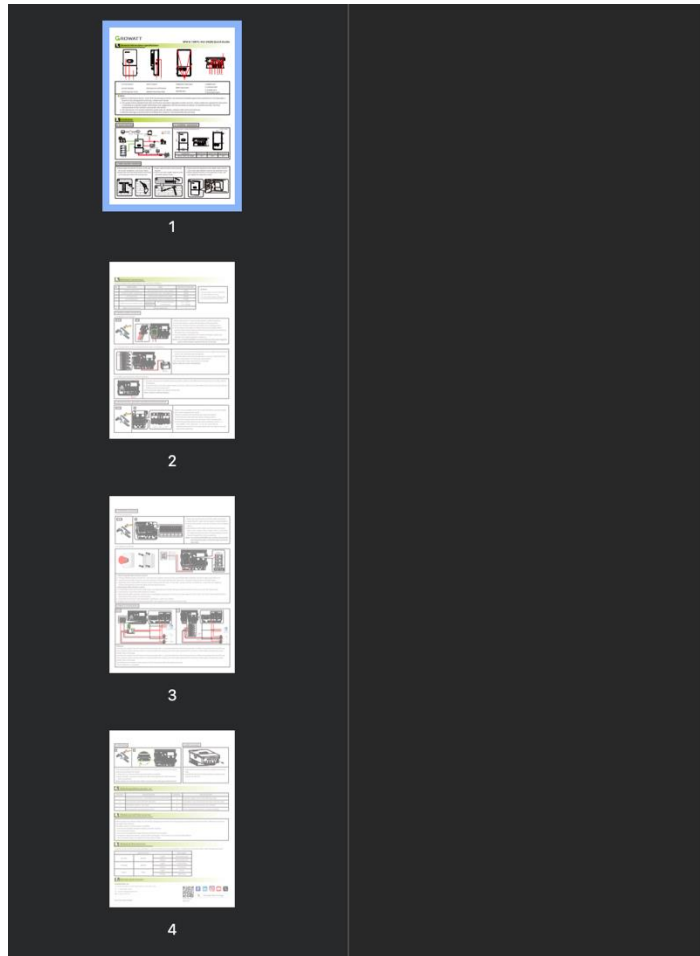

SPH 8-10KTL-HU-US(B) Quick Guide

1. General information-specification

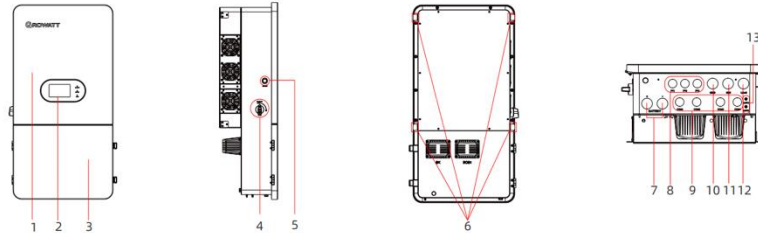

(1) Host panel	(4) PV switch	(7) Battery input port	(10) GEN port
(2) LCD display	(5) Power on/off button	(8) PV input port	(11) LOAD COM
(3) Wiring box cover	(6) Wall mounting hole	(9) COM port	(12) GRID port
			(13) Antenna port

⚠ Note:

- Before installing the device, check that the package contents are intact and complete against the packing list if any damage is found or any component is missing, contact your dealer.
- This guide will be updated from time to time due to product upgrades or other reasons. Unless otherwise agreed this document is intended as a guide only. All information and suggestions do not constitute an express or implied warranty. The final interpretation of the contents is at Growatt's discretion.
- This document is for quick installation guide only. For details, please refer to the User Manual.
- Machine damage caused by failure to follow the content is not covered by the warranty.

2. Installation

2.1 System Overview

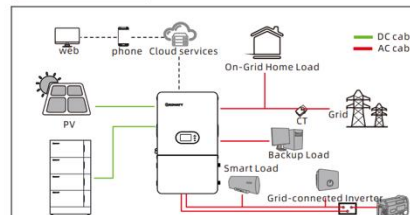

2.2 Installation requirements

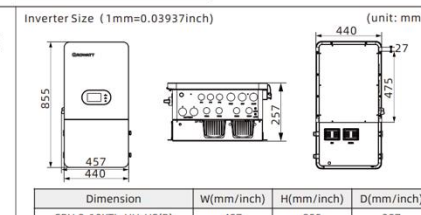

Interface Introduction

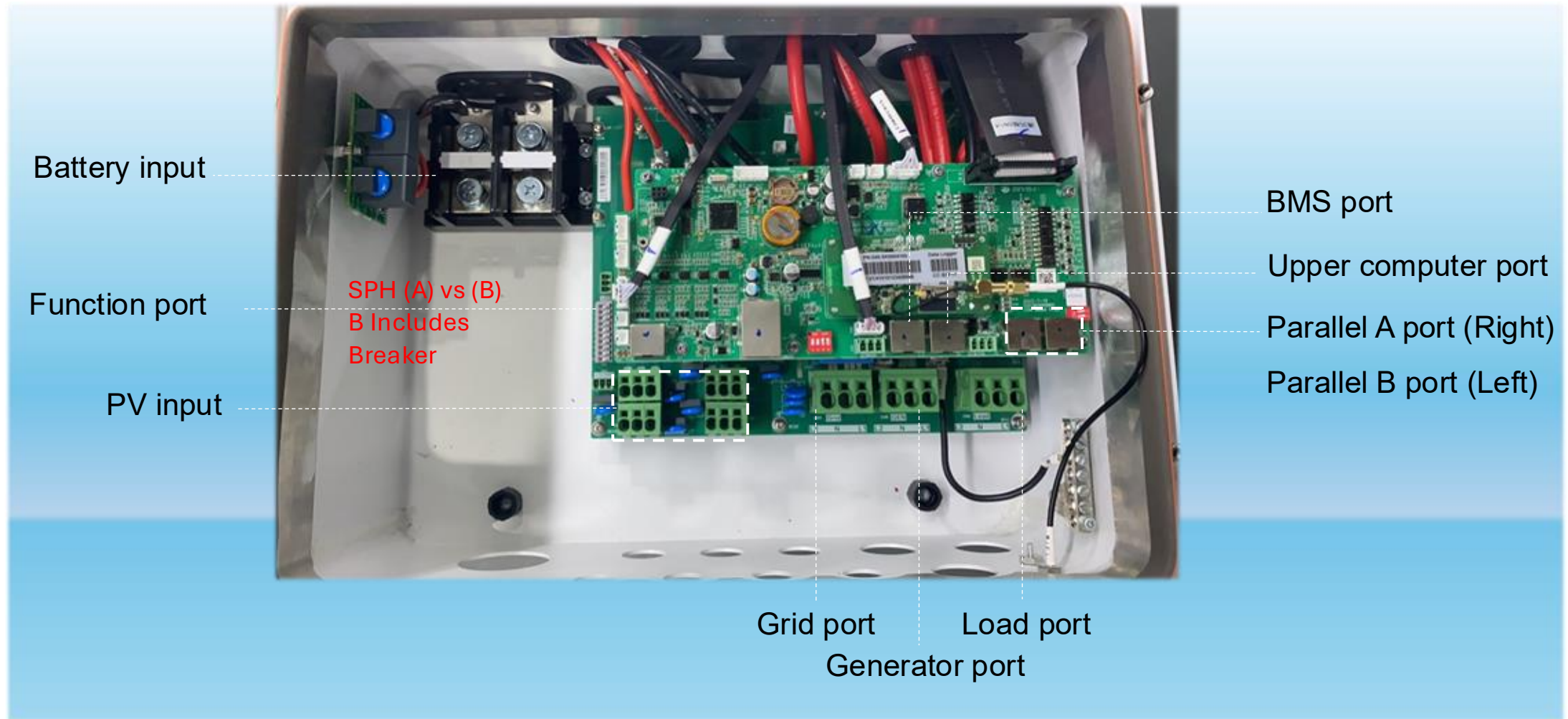

Battery input

Function port

PV input

SPH (A) vs (B)
B Includes
Breaker

BMS port

Upper computer port

Parallel A port (Right)

Parallel B port (Left)

Grid port

Load port

Generator port

Function Port Introduction

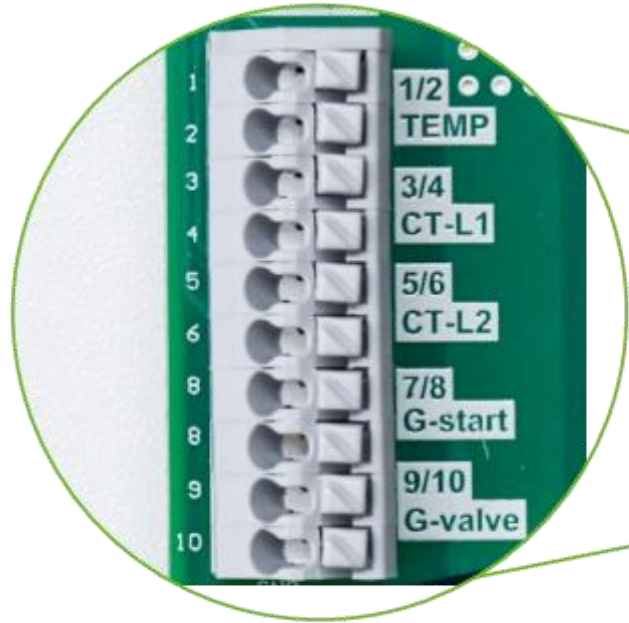

PV Connection

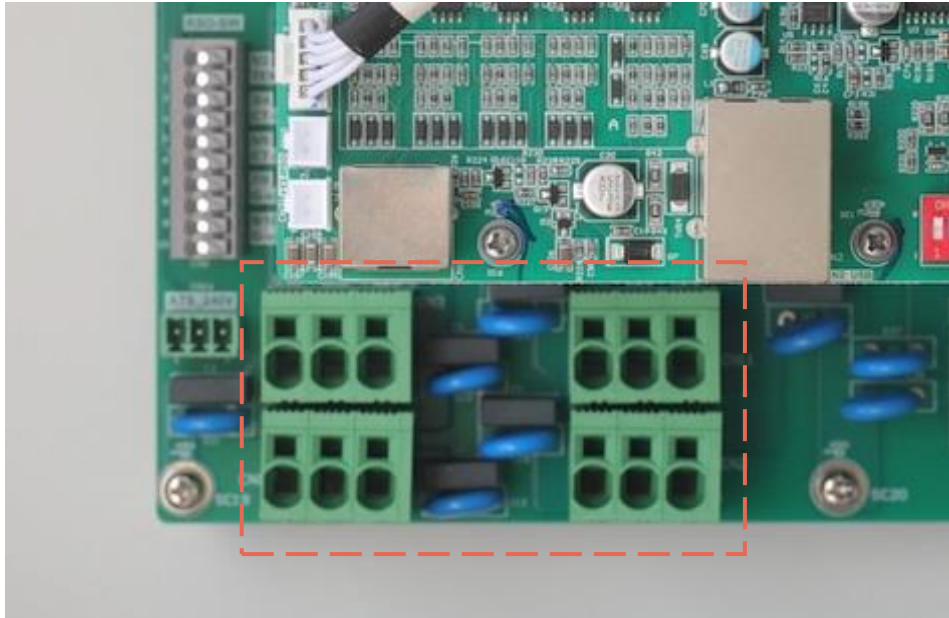

Strip the cable insulation 0.3 inches, then press the connector. Use crimping pliers to firmly press the cable to the tubular terminal in the accessories bag to ensure a secure quadrangle. Insert PV panel positive and negative cables into the relative terminal of SPH 10000TL-HU-US

Limit:

Max. PV voltage: 525V

Full load MPPT range: 150V-450V

Max. PV input current: 22A

Max. PV input power per string: 9.9kW

It is suggested that you use 12 AWG cable to connect

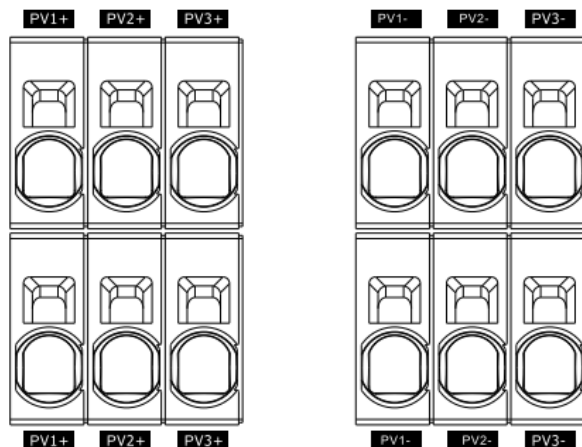

Battery Connection



Please connect battery cables with SC95-12 ring terminal for battery connection. Unscrew the bolts and fit ring terminal in. Fasten the bolt. Make sure the connection is firmly.

limit:

Battery voltage: 40~60V

Max. charging and discharging current: 200A

Max. battery charge/discharge power: 10KW

Ring Terminal: SC95-12

It is suggested that you use 2/0AWG or 4/0AWG cable to connect

AC Connection

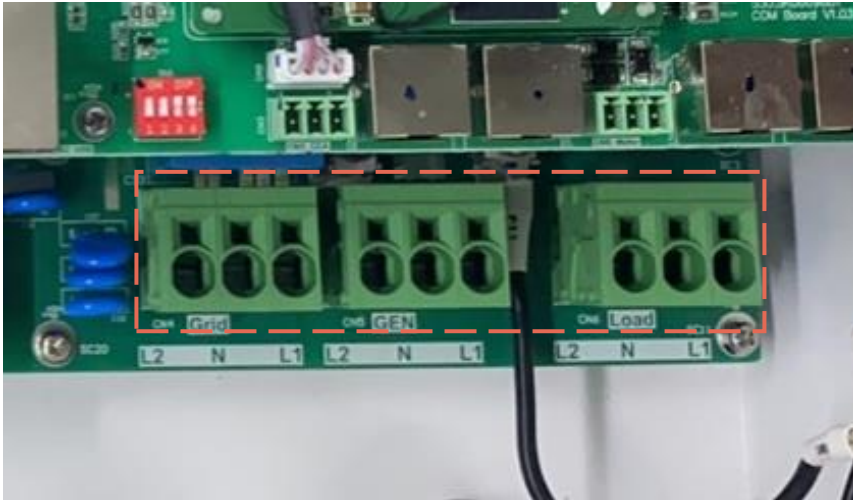

SPH 10000TL-HU-US has three AC ports for Grid, Generator and backup load connection.

Strip the cable insulation 0.3 inches, then press the connector. Use crimping pliers to firmly press the cable to the tubular terminal in the accessories bag to ensure a secure quadrangle. Insert the positive and negative cables into the relative terminal according to the silk screen on the SPH 10000TL-HU-US

It is suggested that you use the 6AWG cable to connect.

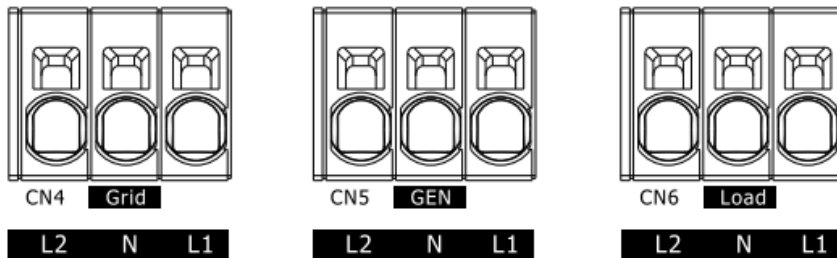

Battery Communication Connection

Lithium Battery Communication Port



If lithium battery is used, please connect the battery communication cable to the BMS port.

Lead-acid Battery Temperature Sensor Port

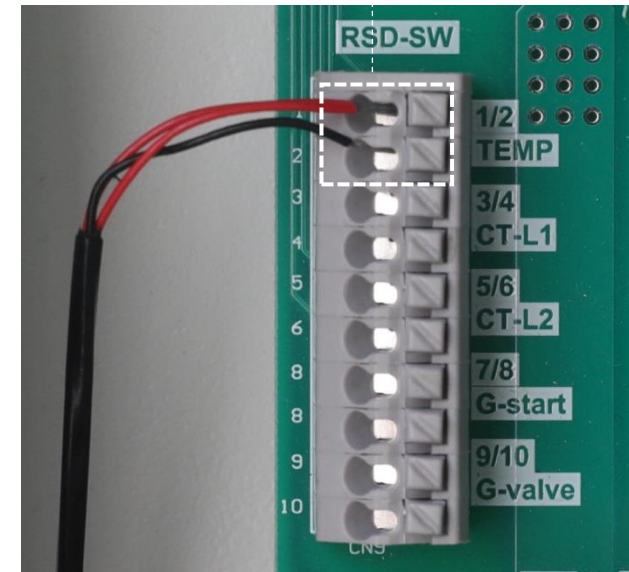

If Lead-acid battery is used, please attach the temperature sensor in the accessory bag to the lead-acid battery. And connect two red wire to the port 1 of functional ports, and black wire to the port 2 of functional ports.

Meter Communication Connection

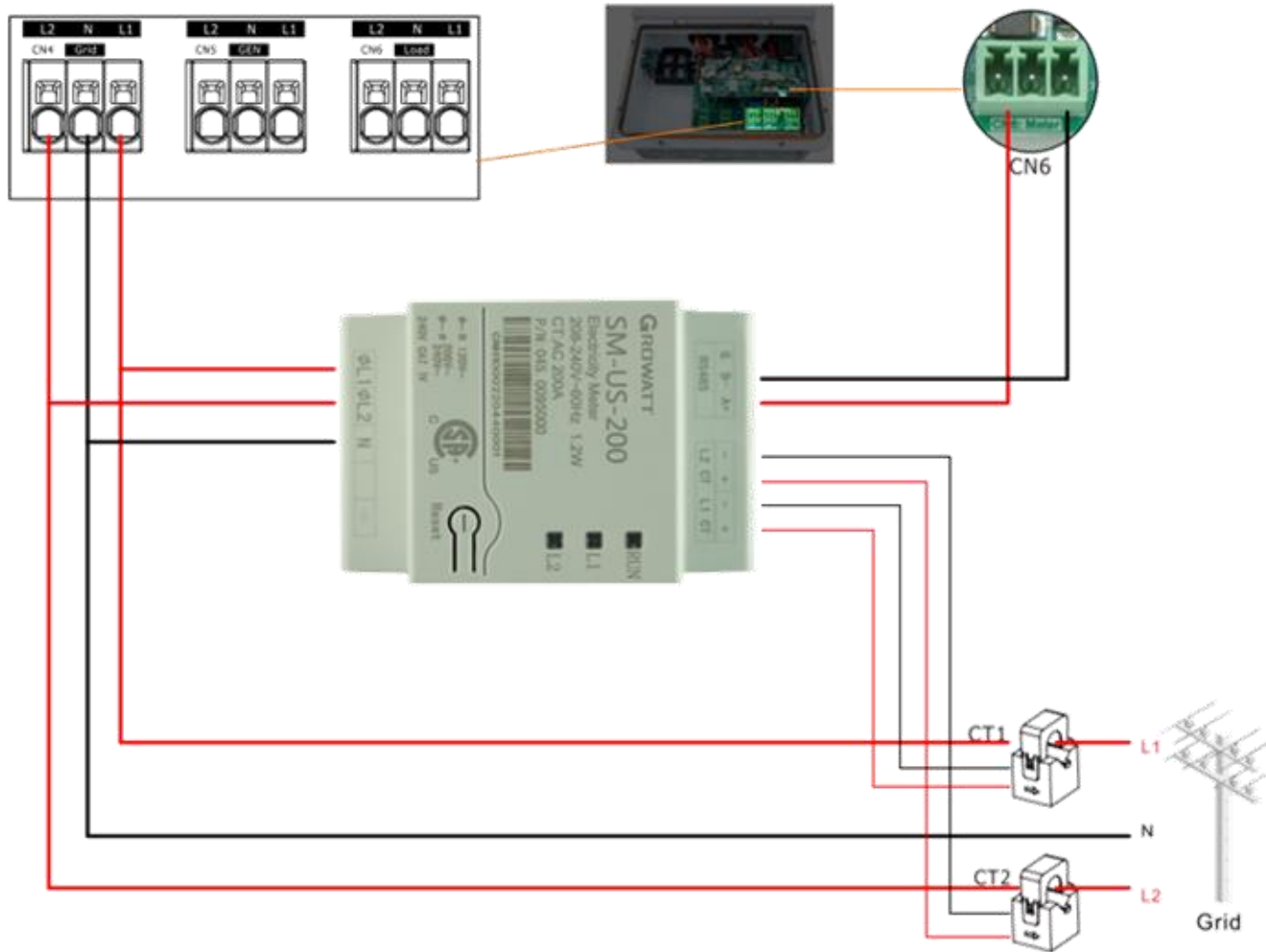

Meter Connection

Cable	Meter	Inverter	Type	Conductor cross-sectional area range
AC wire-L1	ΦL1	n/a	solid or stranded	6AWG
AC wire-L2	ΦL2		wire but not fine	
AC wire-N	N		stranded wire	

If SM-US-200 is used, please install two CT on the accordingly phase, make sure the arrow on the CT points from **load to grid**.

Check the Ex_Meter For CT on the screen.

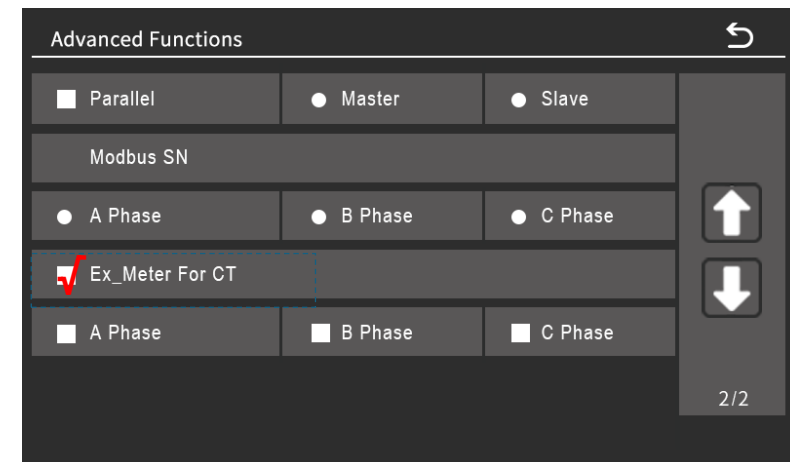

CT Communication Connection

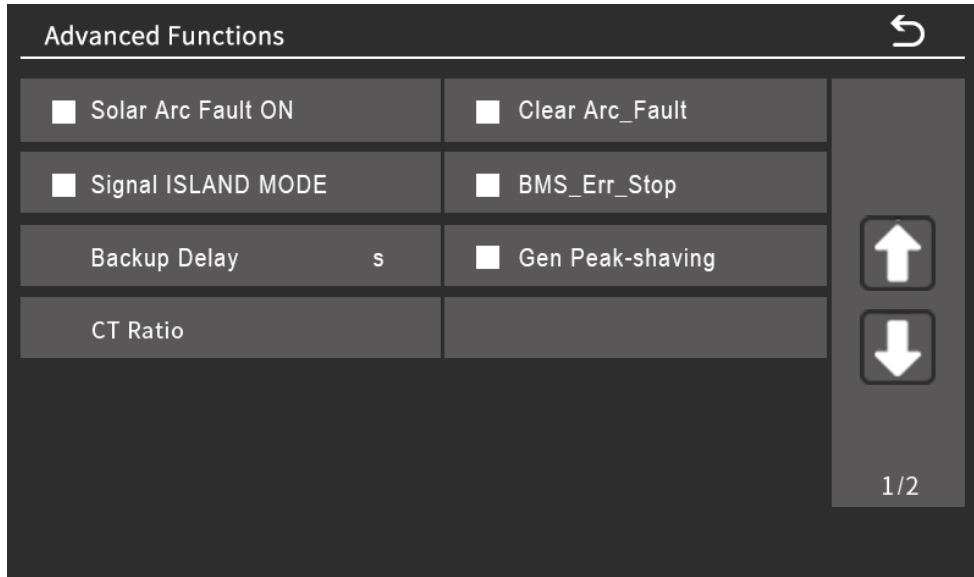

If uses CT to do the power flow monitoring, please install the CT on the right phase and connect the wires as shown on the right.

When installing CT, please make sure the CT direction is correct. The arrow on the CT should point from **load to grid**.

After CT is installed, please set the ratio of CT on the inverter screen.

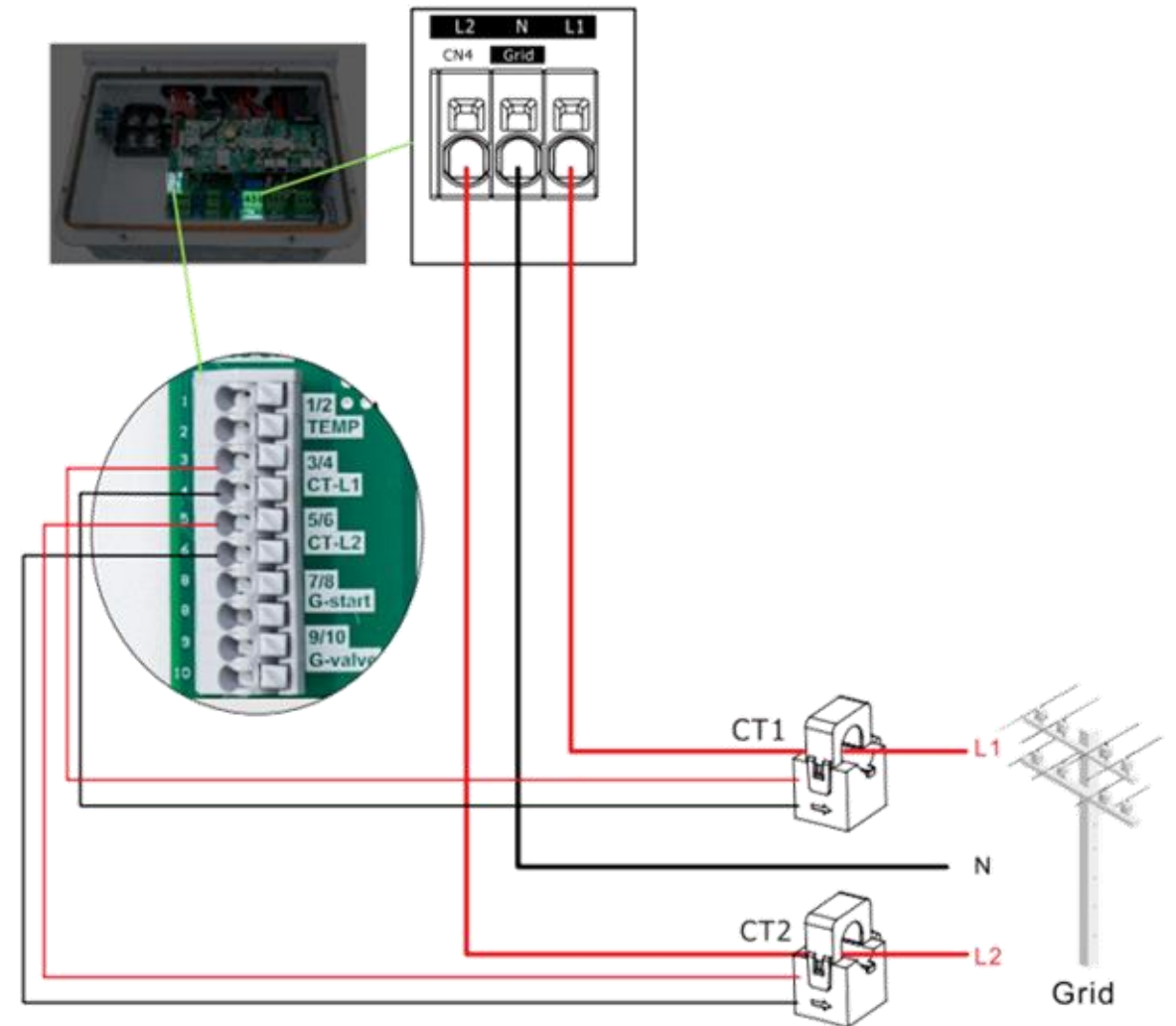

System Startup

Before power on, please make sure all the voltage and current are in the range of specification of hybrid inverter. Otherwise, it will be damage to hybrid inverter.

Follow are the steps of turn on actions:

1. Turn on the switch between Grid and hybrid inverter.
2. Turn on battery and the switch between battery and hybrid inverter.
3. Turn on PV switch. And then turn on switch between PV and hybrid inverter. **Please don't turn on PV switch of inverter under PV voltage, that can damage the inverter.**
4. If need to setup hybrid inverter. Please turn to user manual of hybrid inverter for detail description.
5. The shutdown steps are opposite to the above order.

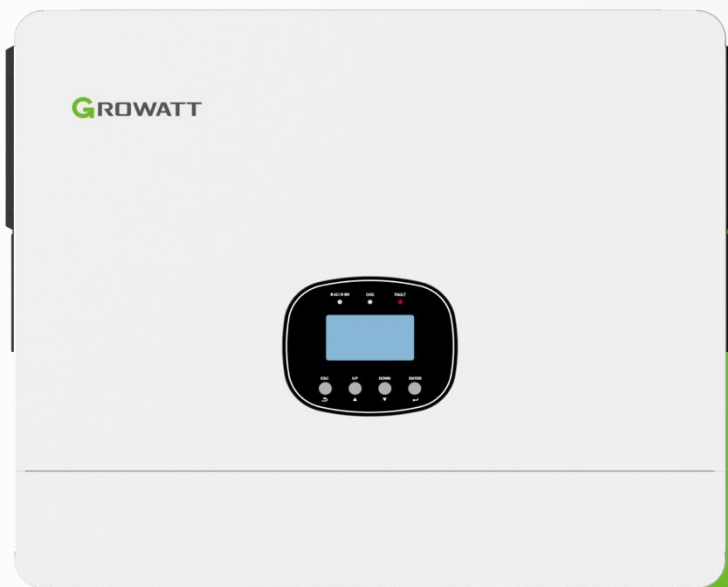

SPE 8000-12000



SHENZHEN GROWATT NEW ENERGY CO.,LTD

GROWATT

Product Overview-SPE 8000-12000TL-HU-US



SPE 8000-12000 US

General

- Off-grid inverter
- Output Power:12000W
- Built in transfer switch
- Two AC input terminals with integrated transfer switch
- 15,000W PV input voltage - 550VDC, 54A, (27/27)
- Dual MPPT trackers

Protection

- IP20 indoor rating
- 5-year product warranty

Leading Features

- Cost effective & Upgrade from the popular SPF models
- Parallel 9 inverters
- Up to 320+kWh of LV batteries per inverter
- Three phase & commercial applications
- Supports Direct Generator Input
- Interface with low voltage batteries

Compatible Battery



Battery Module
ALP 5.0L-E2-US

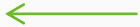

ALP Low Voltage Battery System

- UL9540 certification
- (IP66,NEMA 4X)
- 5.0kWh / Module
- Flexible capacity : 5.0kWh ~ 320kWh
- Excellent safety of cobalt free LiFePO4 battery
- Up to 220A per string, no need for combiner box
- Option for wall mount brackets
- Operating temp. range: -10C to 50C



Key Advantages



Model	SPF 3000-5000 ES	SPE 3500-6000TL HVM-G2	SPE 12000US	Benefits
Parameters				
Maximum PV array open circuit voltage	450V	500V	550V	Each string can be connected to more modules,PV input power up to 18000W
No. of MPP trackers	1	2	2	PV module strings can be installed at different orientations
Max. PV input current	22A	32A(16/16)	54A(27/27)	More PV strings can be connected to increase input capacity, compatible with 500+ PV module
AC input source	Utility power or generator	Utility power and generator	Utility power and generator	No need for the extra ATS device to connect between inverter and the AC source
Air flow	Without filter	Without filter	Dust-proof design	Prevent inverter faults caused by the excessive dust and easy for maintenance
Parallel capacity	6	9	9	The system output power is increased to meet the needs of customers with larger loads.
Generator control	NO	Yes	Yes	Customers can control the working time and current of the DG according to the actual needs to save the fuel costs.
BLVD function	NO	Smart load (3.5-4.5K) Yes (6K)	Yes	Customers can adjust the working hours of non-essential loads according to actual needs

System Startup

Before power on, please make sure all the voltage and current are in the range of specification of hybrid inverter. Otherwise, it will be damage to hybrid inverter.

Follow are the steps of turn on actions:

1. Turn on the switch between Grid and hybrid inverter.
2. Turn on battery and the switch between battery and hybrid inverter.
3. Turn on PV switch. And then turn on switch between PV and hybrid inverter. **Please don't turn on PV switch of inverter under PV voltage, that can damage the inverter.**
4. If need to setup hybrid inverter. Please turn to user manual of hybrid inverter for detail description.
5. The shutdown steps are opposite to the above order.



7-12K AC EV Charger



SHENZHEN GROWATT NEW ENERGY CO.,LTD

GROWATT

Product Overview-AC EV Charger



THOR 07/09/12AS-P US

THOR EV Charger US

THOR 07/09/12AS-P US

240V 7-12kW Level 2 Residential Fast Charger
Single J1772(Type 1) output plug

IP65 NEMA 4X outdoor rated -22°F~122°F

Charging time 4-7 hours

System Overview

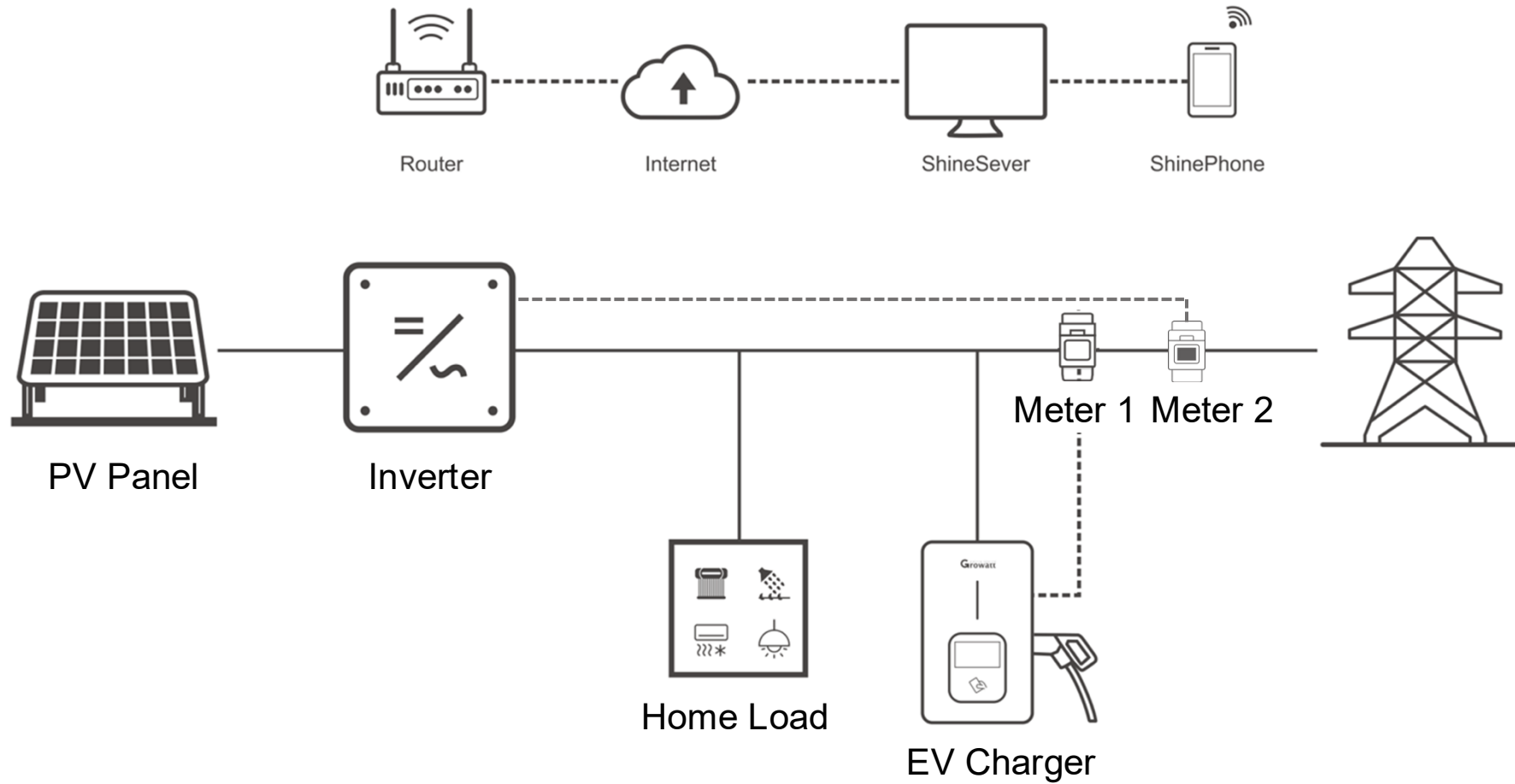

*Note: To use the PV-linkage mode and Load balance function, users will need to connect an additional meter with EV charger.

Smart Meter Products



Single Phase Meter



Three Phase Meter

Products	Model Name	Meter Name
THOR 07AS-S/P-V1 THOR 07AD-PE/PEW/SE/PEW	SPM-CT-E	Eastron SDM 120 MID
	/	CHNT DDSU666
	SPM-E	Eastron SDM230-Modbus
THOR 11~22AS-S/P-V1 THOR 11~22AD-SE/PE/SEW/PEW THOR 20DS-P THOR 40DS/DD-P	TPM-E	SDM630-Modbus V3
	TPM-CT-E	SDM630MCT-Modbus V2
	TPM-CT-C	CHNT DTSU666
THOR 7~12AS-P US	SM-US-200	SM-US-200

*Note: If users need PV Linkage mode or Load Balance function, then this extra smart meter is needed

THOR AC EV Charger Introduction

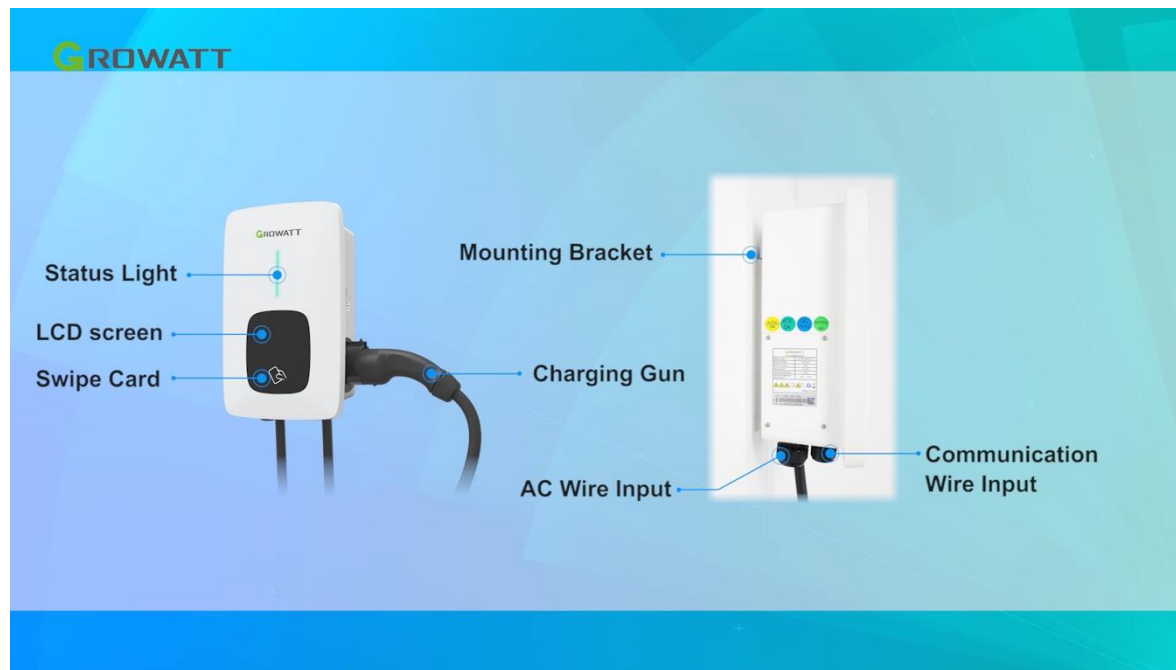

- Status light
- LCD Screen for three phase EV chargers
- RFID swipe area
- Mounting bracket
- Charging gun for -P version
- AC wire input
- Communication wire input



THOR EV Charger

Installation & Commissioning Guidelines



AC Input Connection - AC EV Charger



Open the side wiring box. Insert the power cable into the connection box. Connect the power cable to the corresponding terminal and fasten them.

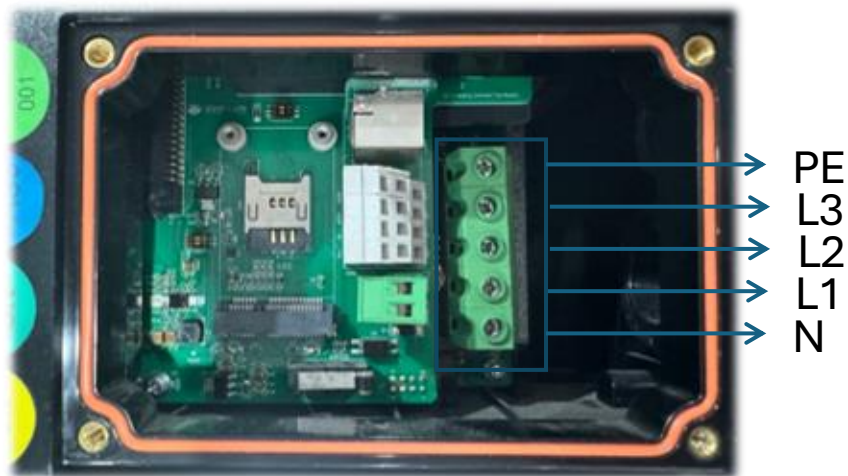

Terminal Model	L1	L2	L3	N	PE
7k	9AWG	/	/	9AWG	9AWG
11k	12AWG	12AWG	12AWG	12AWG	12AWG
22	9AWG	9AWG	9AWG	9AWG	9AWG

Communication Wiring

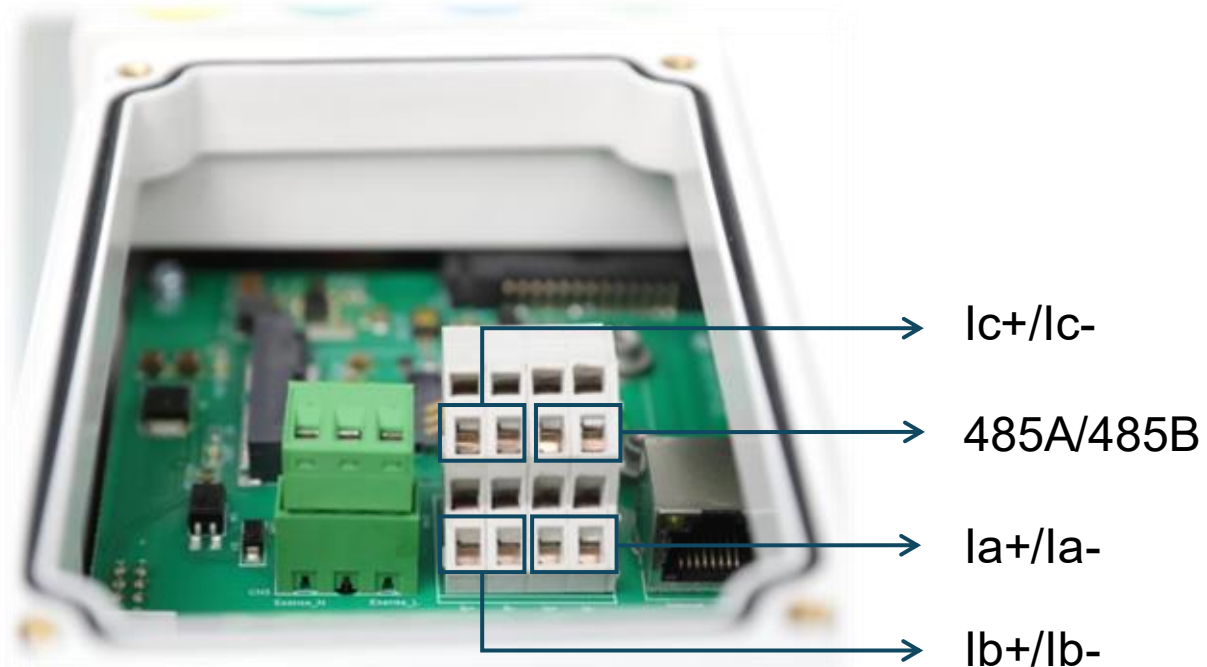

To use the PV-linkage mode and load balance function, an additional Meter is needed.

Open the terminal by inserting the screwdriver into the conductor port above it. Insert the communication cable. Pull out the screwdriver and the cable will be clamped by the plug-in terminals.

- 485A,485B is RS485 terminal to connect to the communication wire of energy meter
- Ia+/Ia-, Ib+/Ib-, Ic+/Ic- are for CT connection.
- For single phase EV charger, please connect Ia+/Ia- if CT is used.

SPM-CT-E Connection

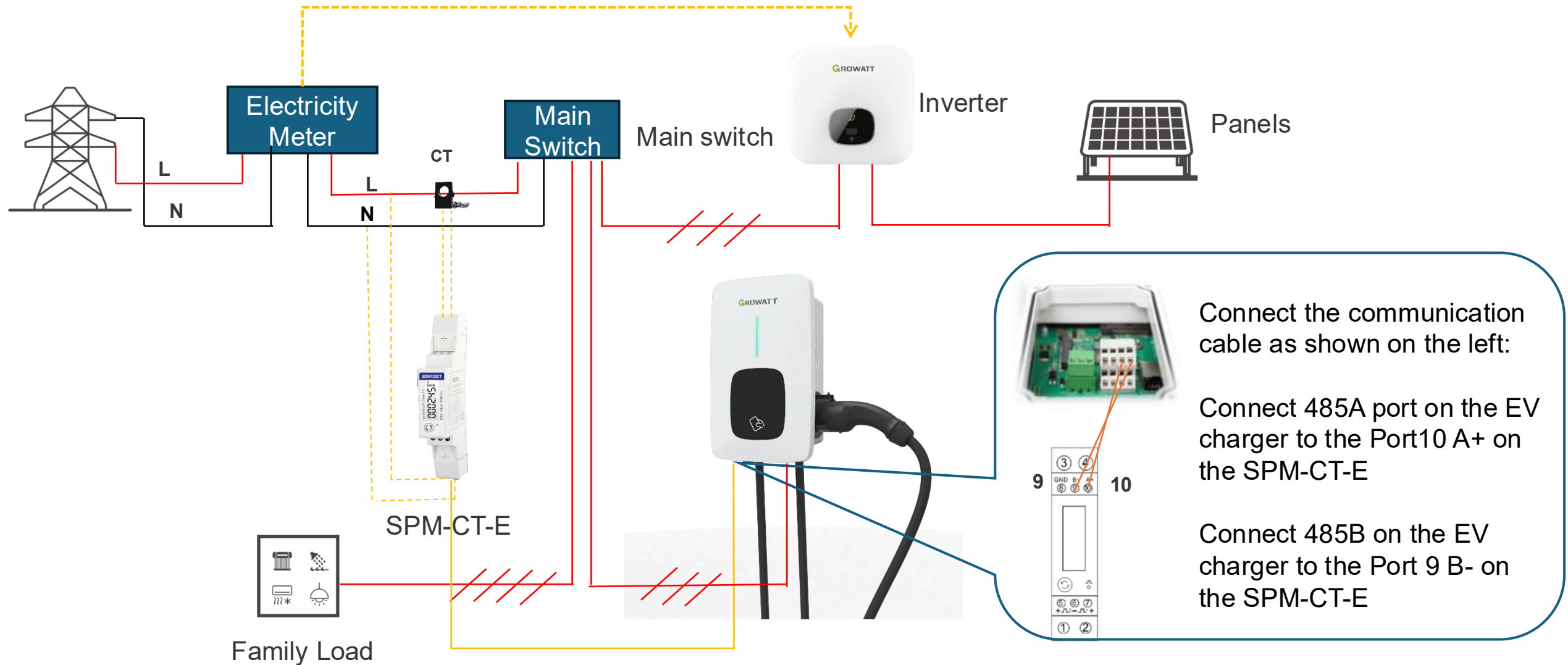

*Note: When installing CT, please make sure that the arrow on the CT points from grid to EV charger

SPM-E Connection

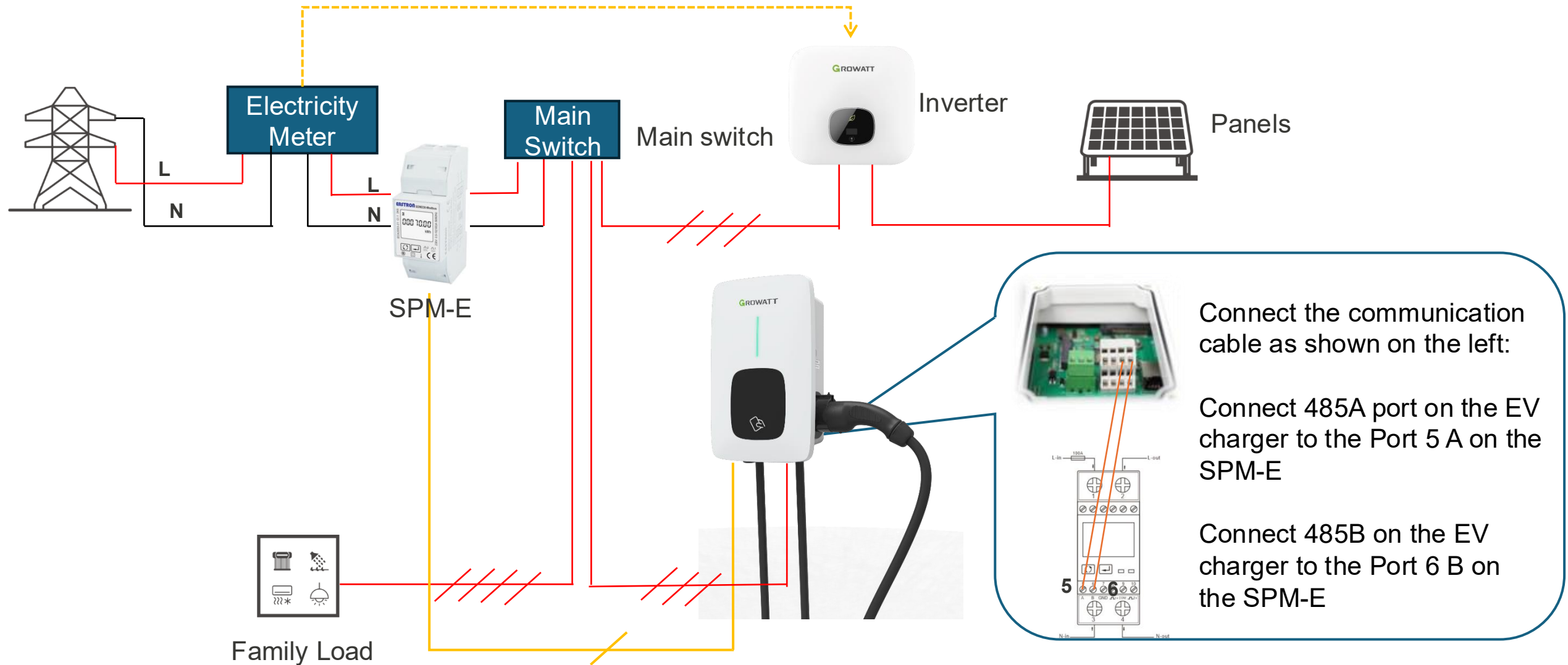

TPM-CT-E Connection

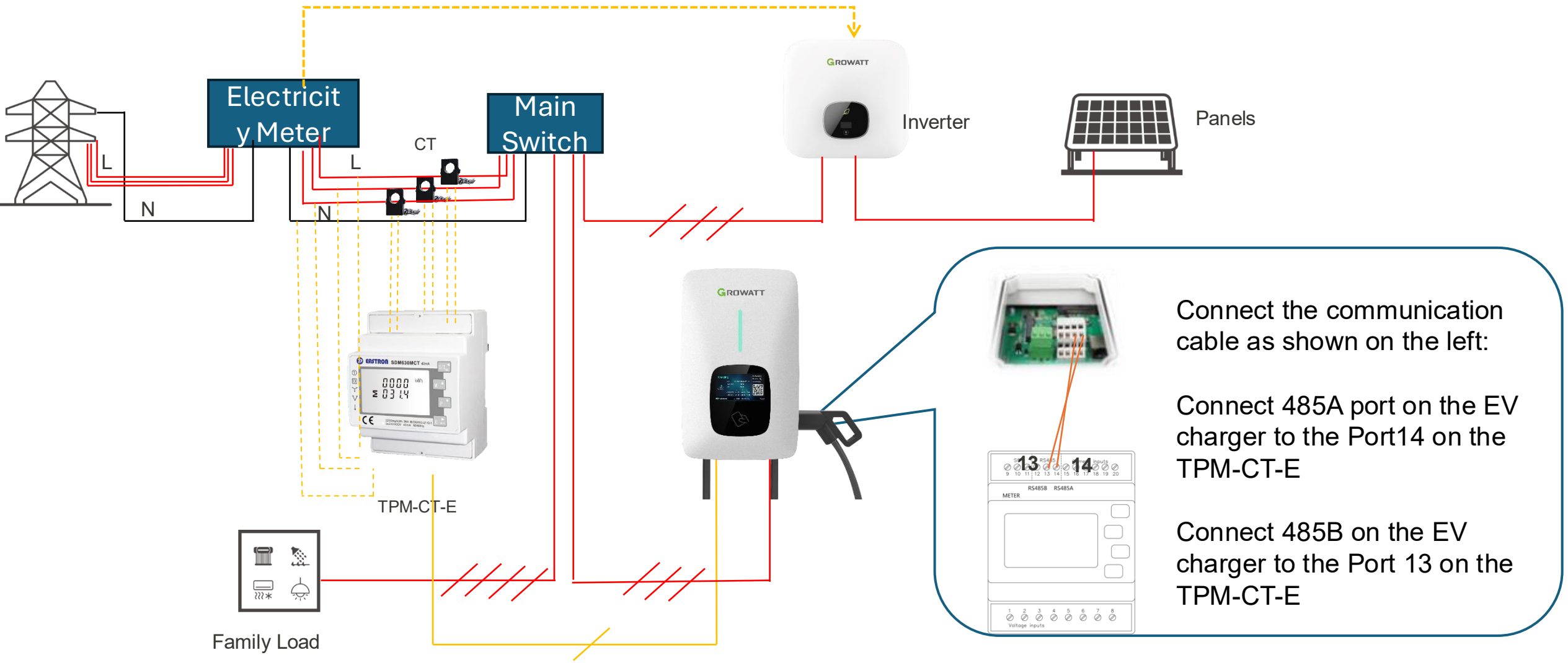

*Note: When installing CT, please make sure that the arrow on the CT points from grid to EV charger

TPM-E Connection

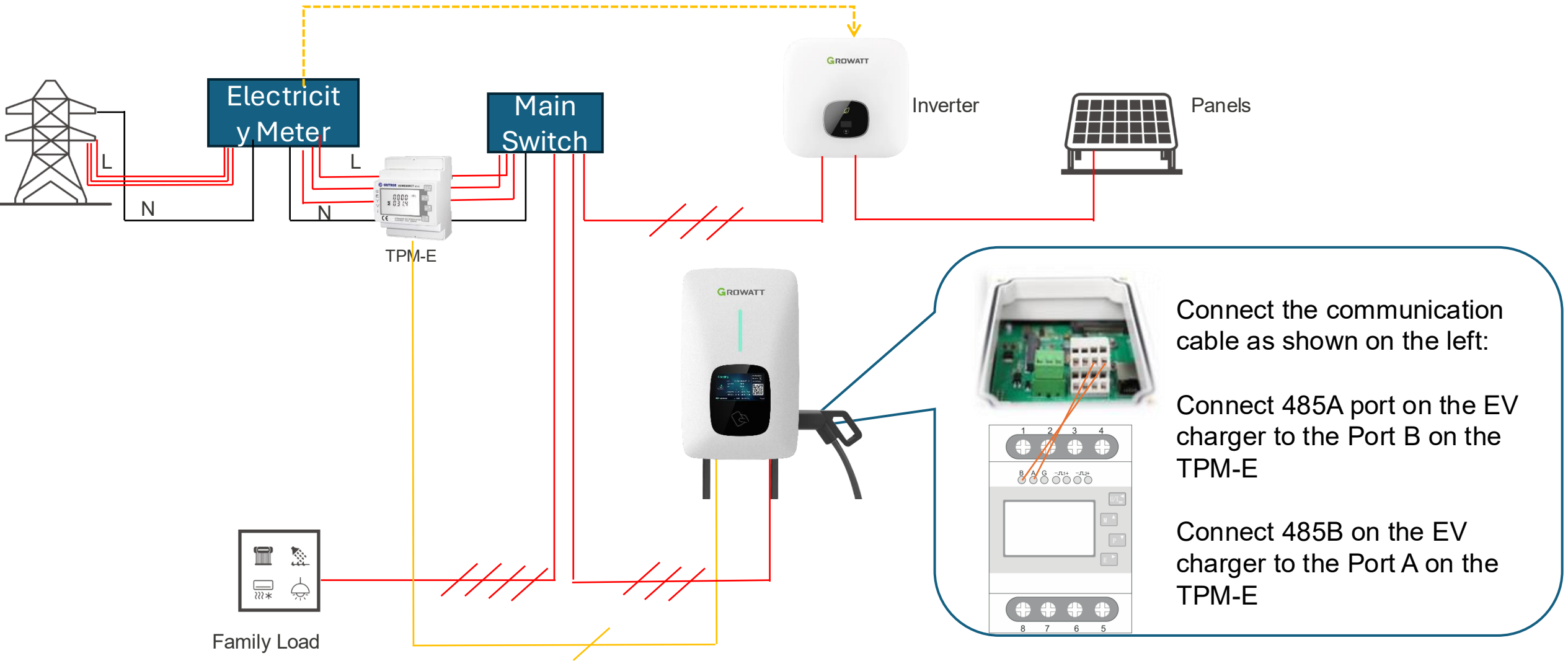

Communication by LAN or 4G

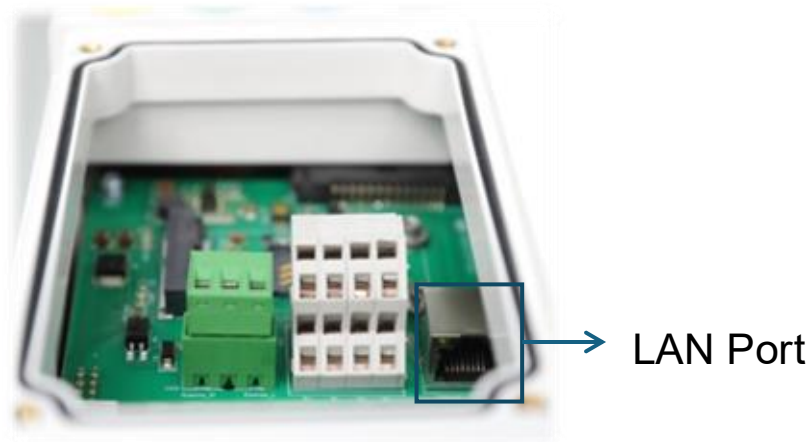

If uses Ethernet to do the communication. Please insert the network cable through the communication hole and connect it to the LAN port.



Place to add 4G module



4G module

If uses cellular to do the communication. Please purchase an extra GW 4G module and install it to EV Charger to add the 4G function. Install a local sim card to use cellular to do the communication.

→ [Go to APP Configuration](#)
→ [Go to EV Charger Settings](#)

Shine Phone APP Settings Guide for EV Charger

Step 1: Download & Install the ShineTools APP from Android or iOS App Store

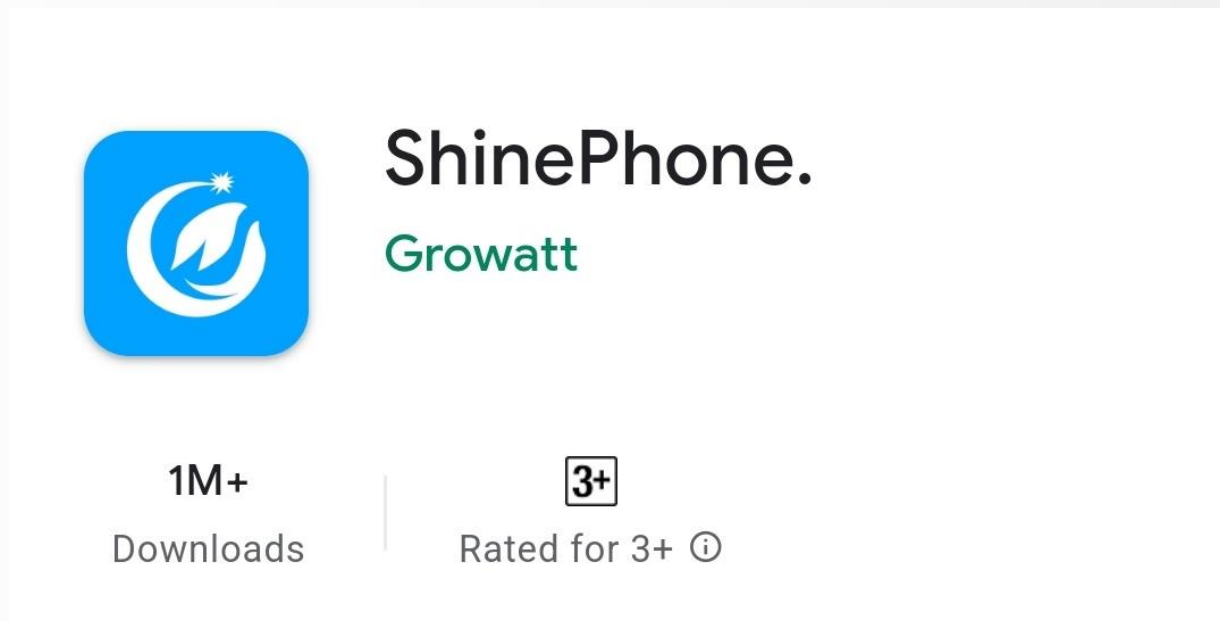

**Shine Phone For Installer commissioning
&
Residential end user monitoring and use**

APP Configuration - Register and Add Plant

If you do not have Shinephone account and never used Shinephone before. Please follow the instruction below. If you already have a Shinephone account with a charging plant, please skip the instruction on this page.

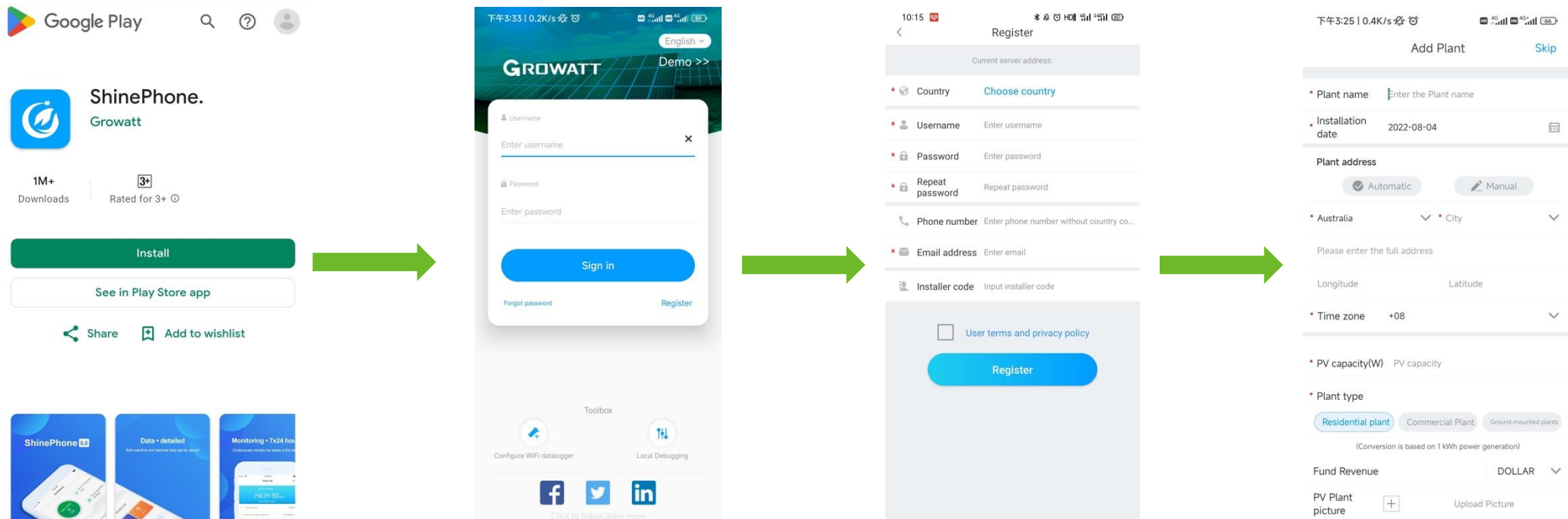

- Please download Growatt Shinephone app from Google play or Apple store.
- Click the 'register' and fill in the needed information.
- After registration, please build a plant for adding EV charger.

APP Configuration - Add EV Charger

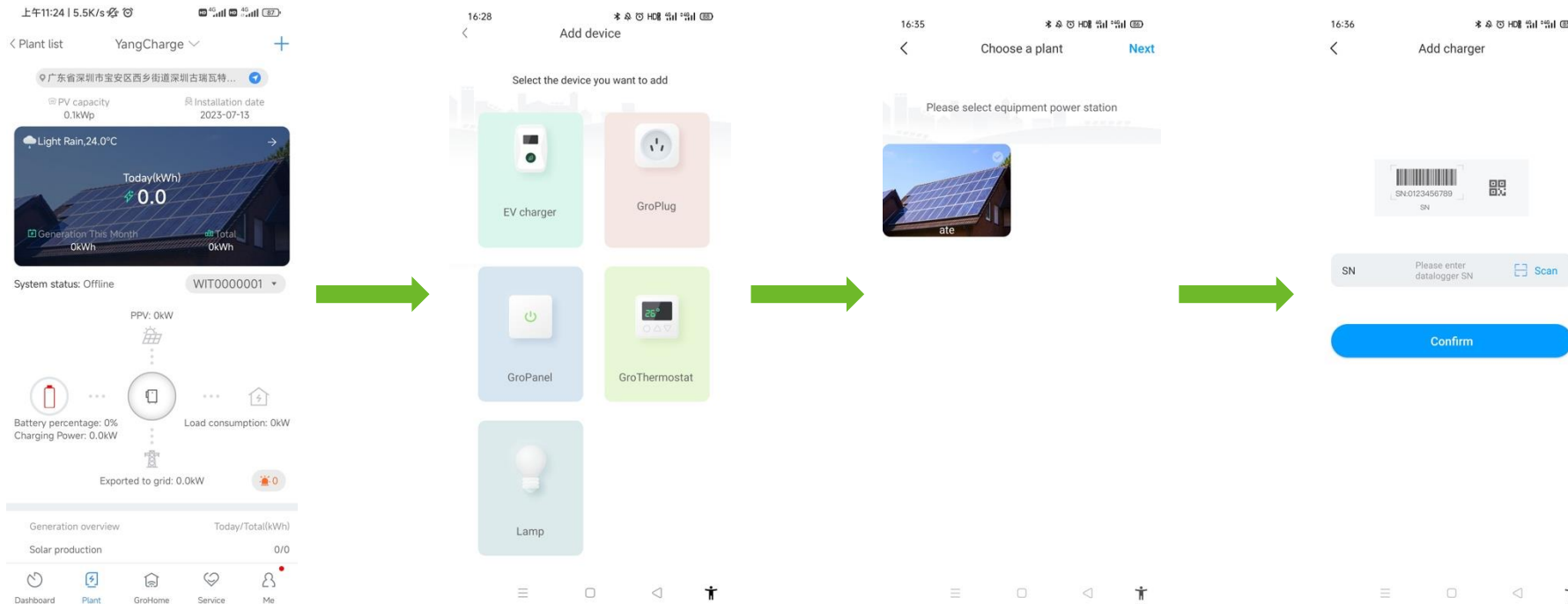

- Go to the Plant page, and click the + icon on the upper right.
- Select EV Charger
- Choose a plant where you want to add your EV charger
- Scan the SN bar code on the EV charger or manually input the SN of the EV charger.

APP Configuration - Network Connection 4G and WiFi

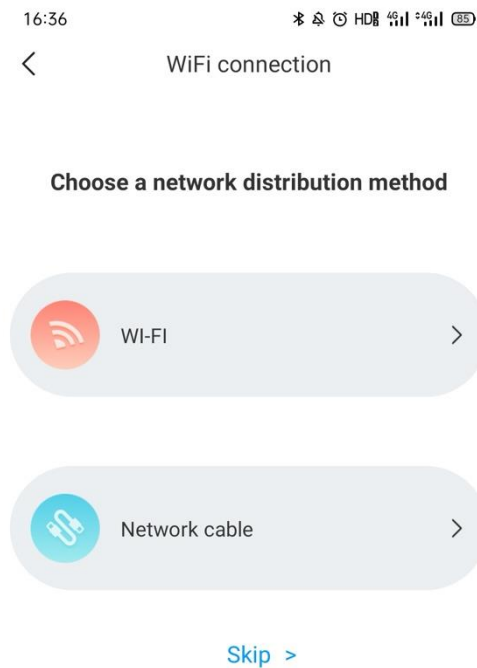

4G: If EV charger uses cellular to do the communication, please click 'Skip'. Please make sure that 4G module and sim card are installed.

WiFi: If you want to use WiFi to do the network communication. Please click 'WI-Fi'. And follow the steps on the next page.

APP Configuration - Network Connection LAN

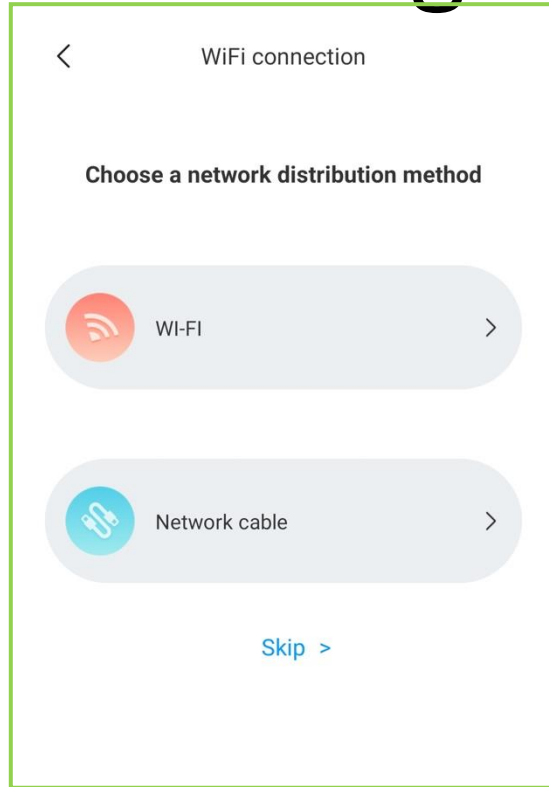

Please make sure that your internet cable is plugged in and select 'Network cable' if you want to use Ethernet to connect to network.

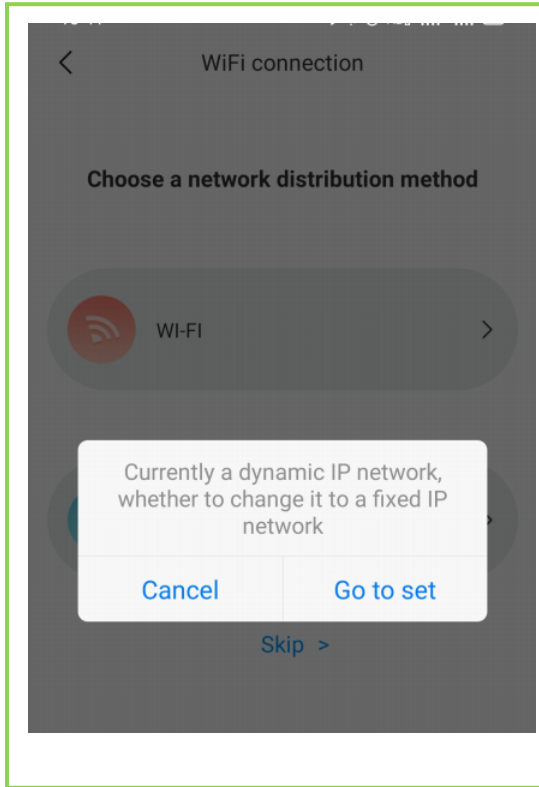

Click Cancel if you want to use dynamic IP. Please wait for 2~5 minutes to see if the communication is successful.

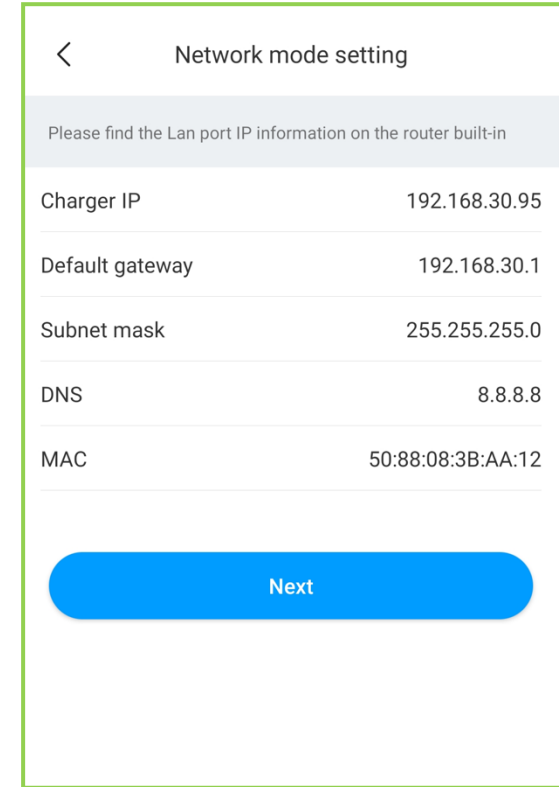

Click Go to set if you want to use fixed IP. You could set a fixed IP in this page

APP Configuration - WiFi Configuration

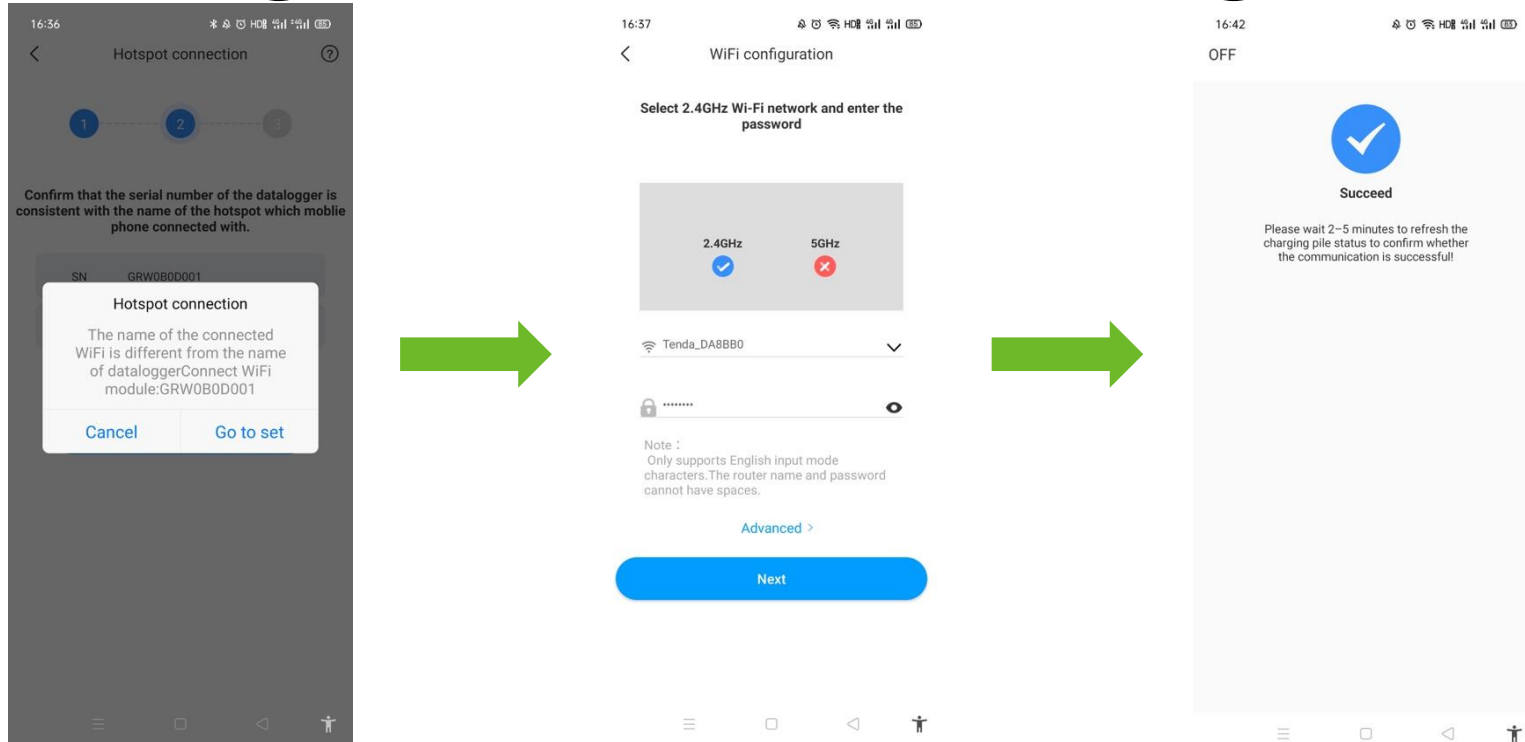

- Step 1. Please go to the WiFi setting page on your phone and enable the WiFi function.
- Step 2. Connect your phone to EV chargers. Connect to the hotspot shared by the EV charger. Its name is consistent with the SN. The default password of the hotspot is 12345678.
- Step 3. Connect EV charger to WiFi. Go back to the Shinephone and choose the WiFi you want to connect to. And enter its password.
- Step 4. Click 'Next' and wait for 2~5 minutes to see if the connection is successful.

Meter Setting

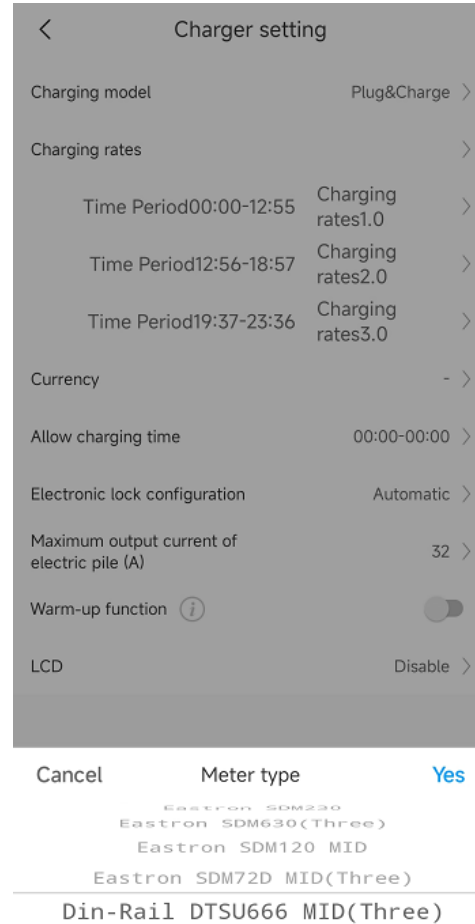
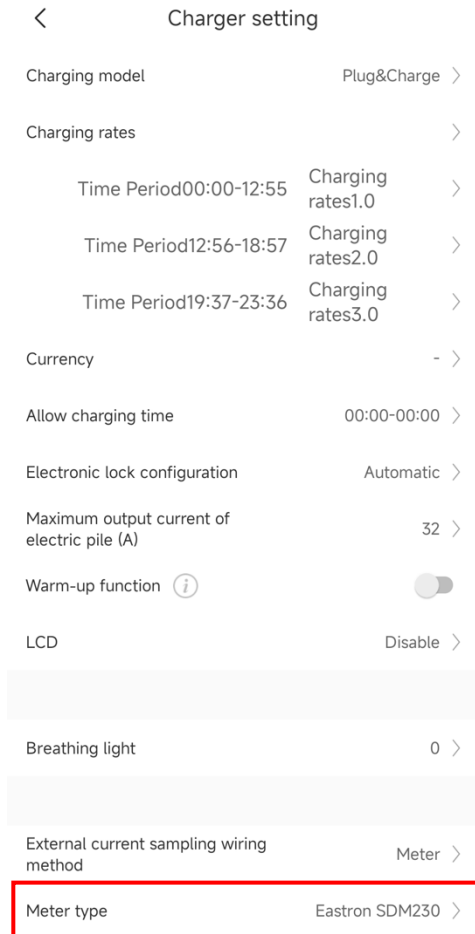

After the CT or energy meter is installed, please choose the external current sampling method under the charger setting page and choose the corresponding CT or energy meter.

Working Mode

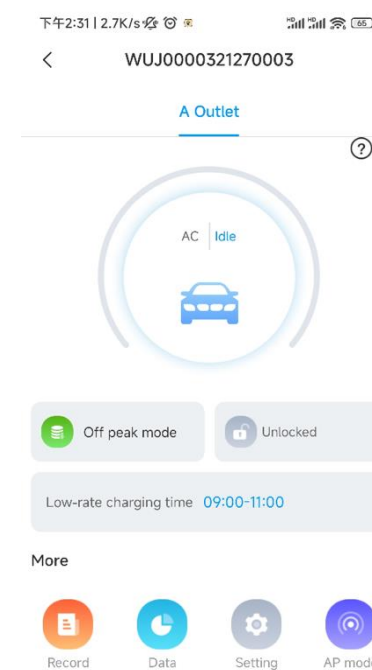
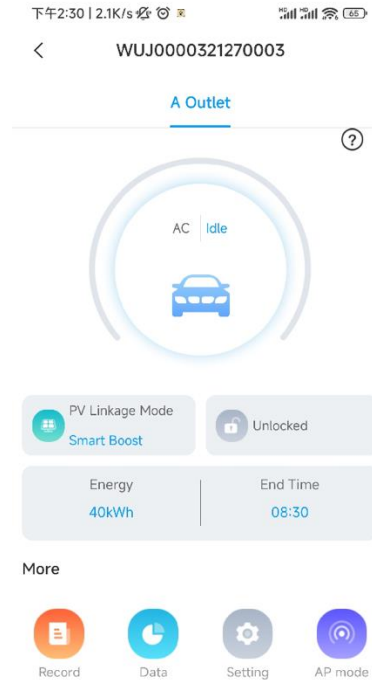
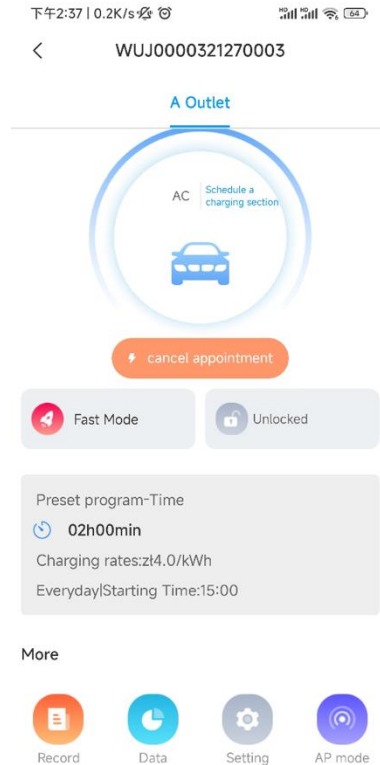

There are 3 mode you could choose: Fast Mode, PV Linkage Mode and Off Peak Mode. Click the current working mode to change it.

- Fast Mode: Always charge your car with its maximum charging power.
- PV Linkage Mode: Always charge your car with excess solar power.
- Off Peak Mode: Always charge your car when the electricity price is low.

Working Modes

Fast Mode

The EV will be charged at maximum power coming from a renewable energy source or simply from the grid, especially for quick charging if you're in a hurry, and support multiple control strategies of timer, charging capacity, charging budget

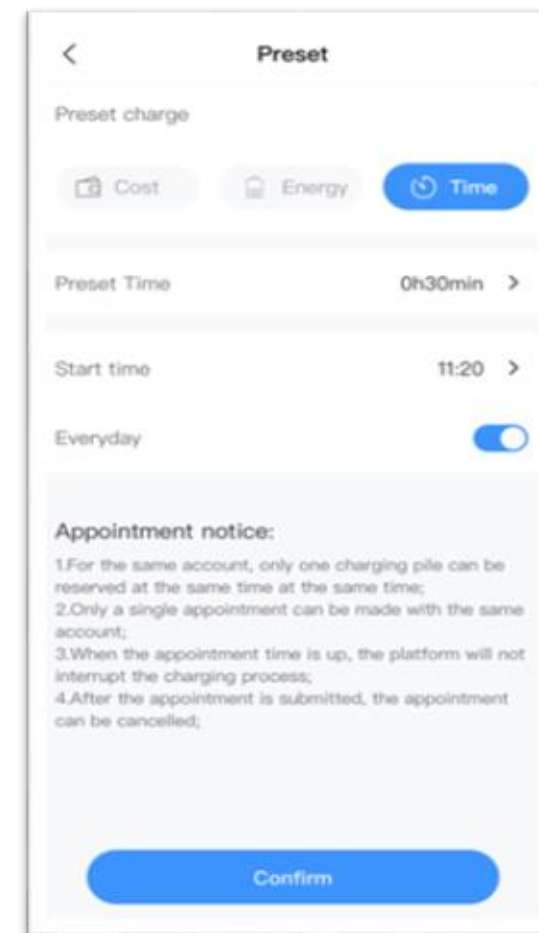
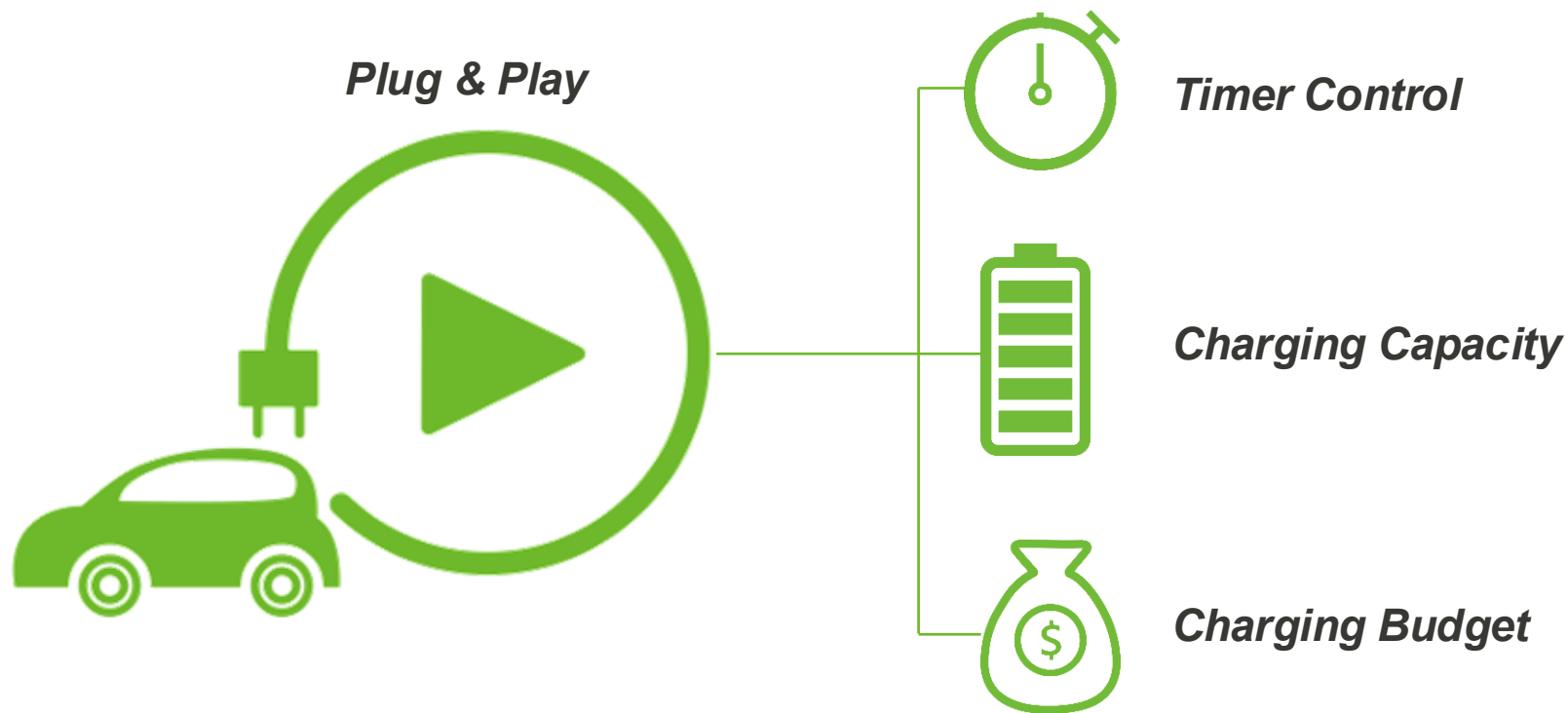

Working Modes

Off-Peak Mode

Once enable the Off-Peak mode, the EV charger will automatically charge the EV when it's at off-peak time to reduce the electricity bills.

LOWEST COST
 IDEAL CHARGING TIMES: 11PM-7AM

HIGHER COST
 AVOLD CHARGING : 7AM-11PM

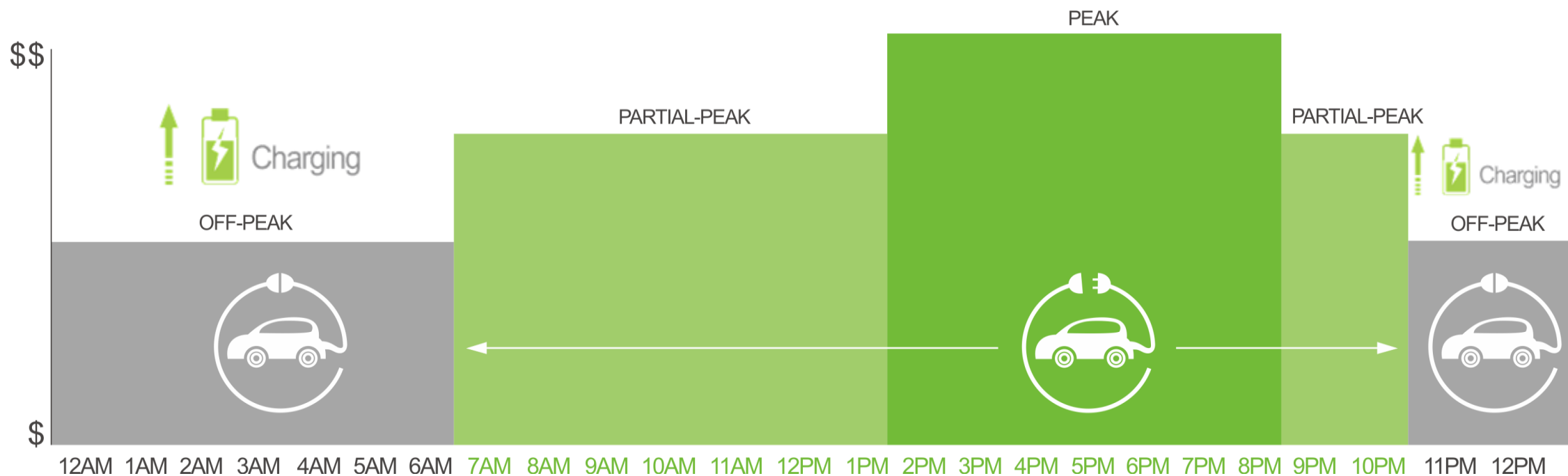

* Customer is required to input all their electricity fees manually

Working Modes

Off-Peak Mode

Once enable the Off-Peak mode, the EV charger will automatically charge the EV when it's at off-peak time to reduce the electricity bills.

■ **LOWEST COST**
IDEAL CHARGING TIMES: 11PM-7AM

■ **HIGHER COST**
AVOID CHARGING : 7AM-11PM

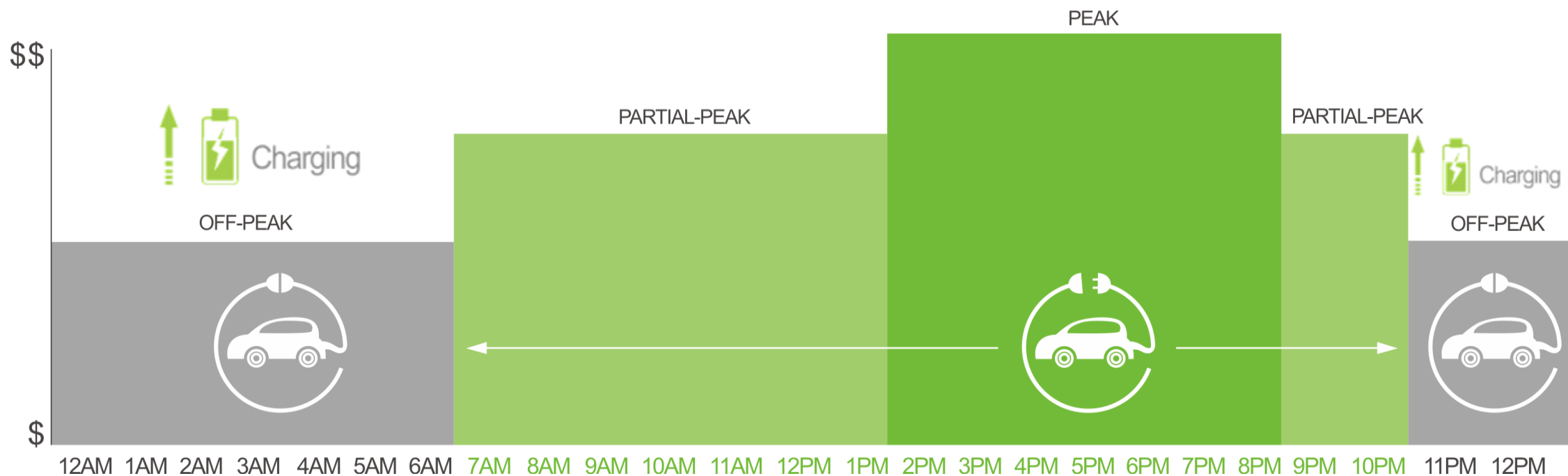

* Customer is required to input all their electricity fees manually

Working Mode Setting - Off-peak Mode

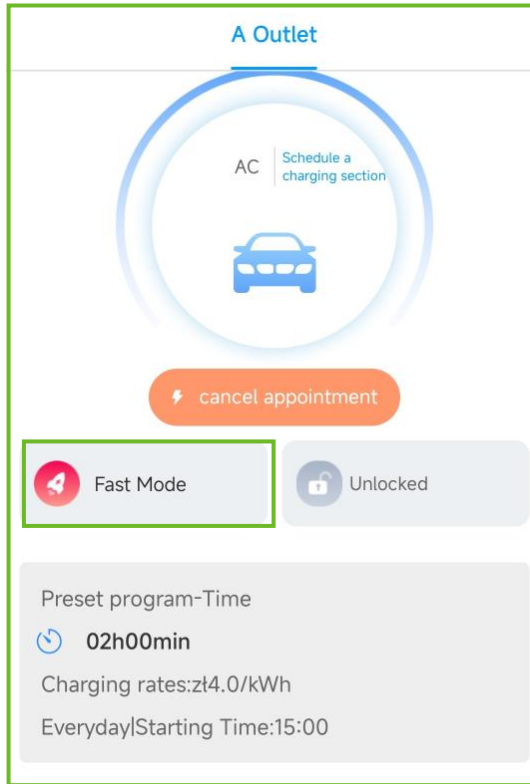

Click here to change the working mode.

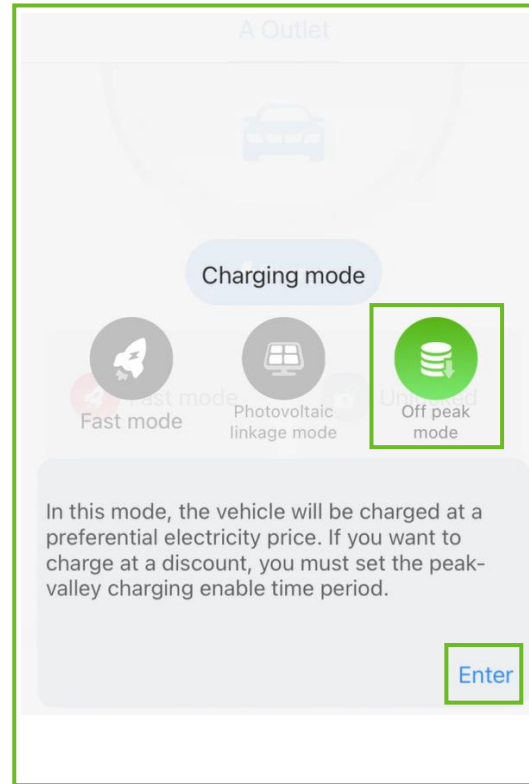

Choose Off-peak mode and click Enter to enter the setting page.

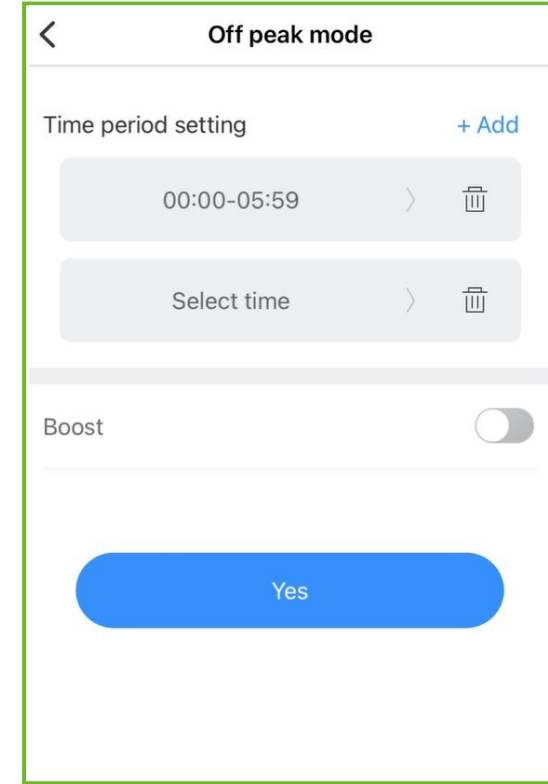

Fill in the time period when electricity is cheap

Working Modes

PV Linkage Mode

Driven by solar, charge your car with 100% renewable energy, the EV will be charged by the surplus solar power dynamically, combining PV and EV charger together to maximize the solar self-consumption rate and cut your bill.

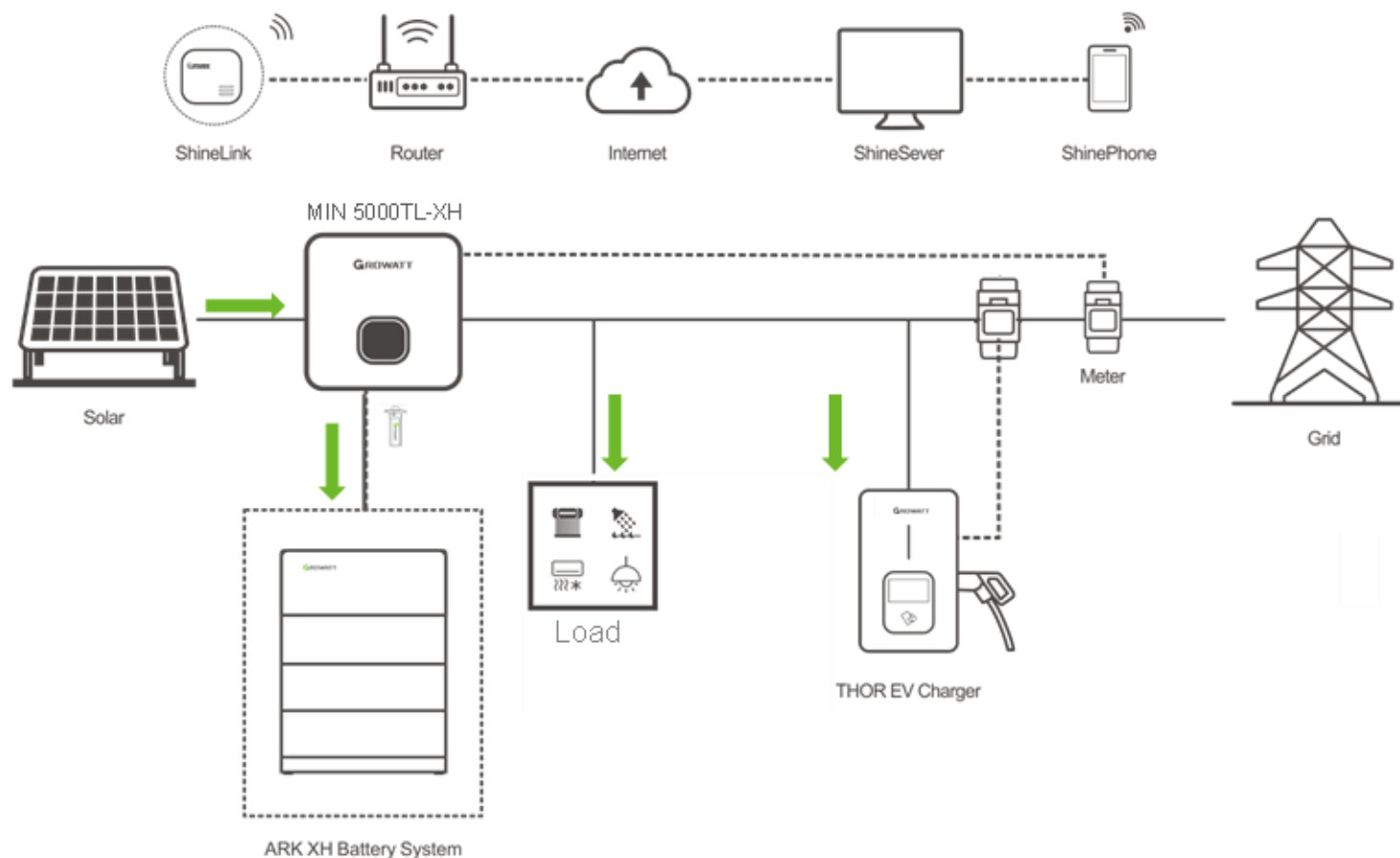

*The solar system cannot enable the zero export limitation function if enabling the PV linkage mode of EV charger

Working Mode Setting - PV Linkage Mode

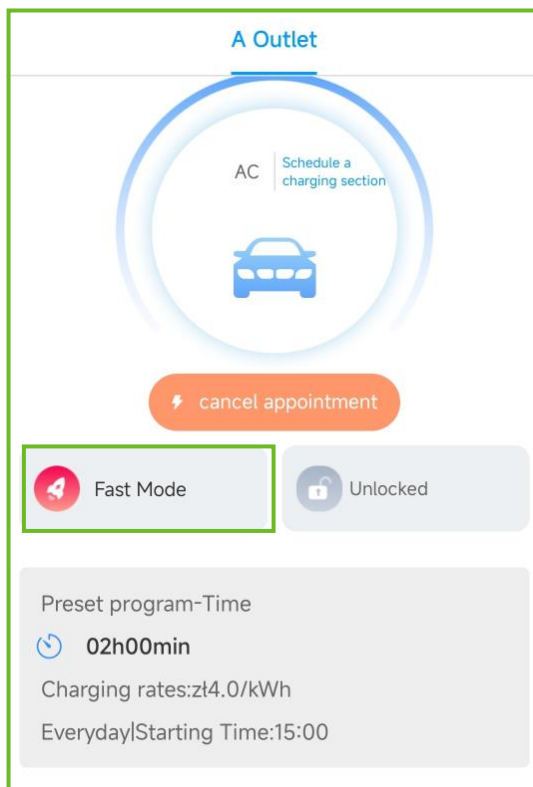

Click here to change the working mode.

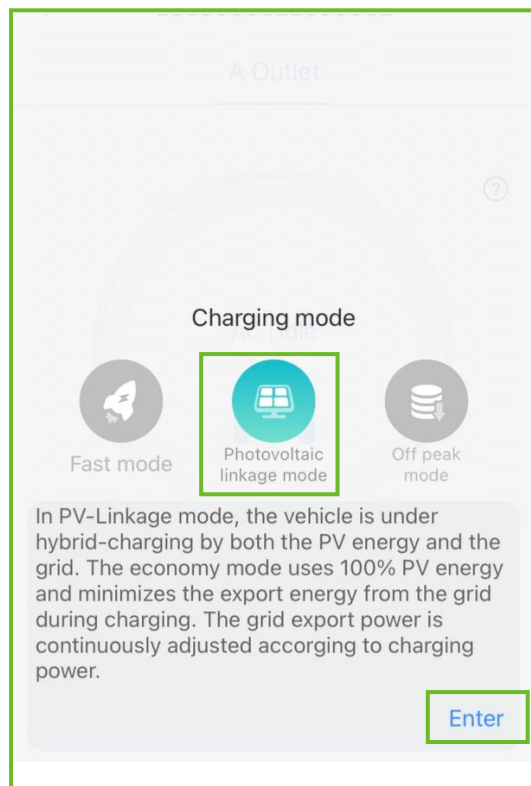

Choose PV linkage mode and click Enter to enter the setting page.

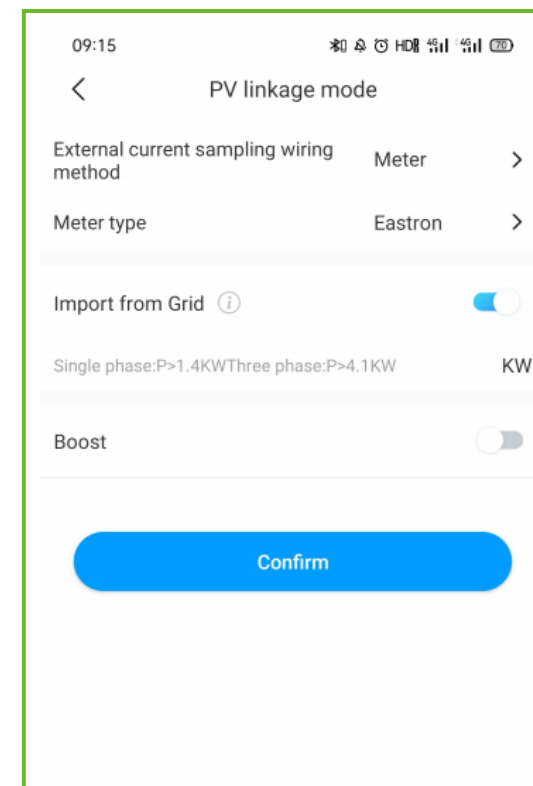

Select the current spamling device type and choose if you want to enable power from the grid if excess PV power is lower than the Min. operation power

Working Modes

Load Balancing

The EV Charger offers power balancing function at home, the EV charger can read the incoming power to the house with an additional CT. Then the EV charger will adjust its charging power dynamically according to the home power to avoid exceeding the limited point, always charge your car at its maximum charging speed without triggering the limited value

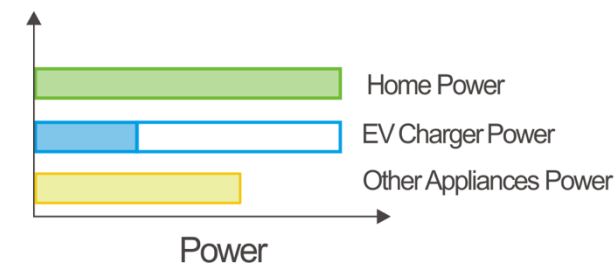
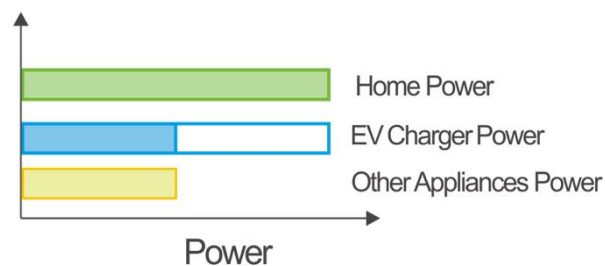
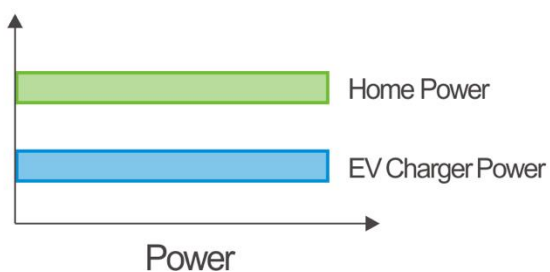

Function Setting - Load balance

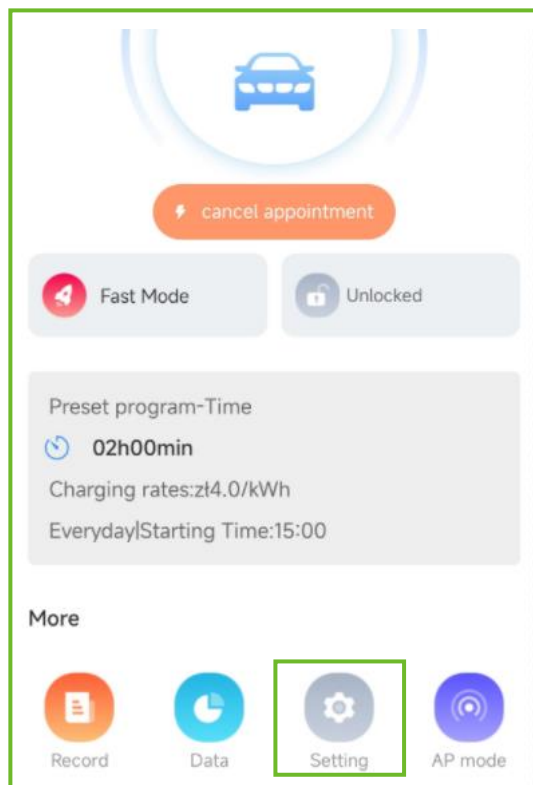

Scroll down and click Setting to enter the setting page.

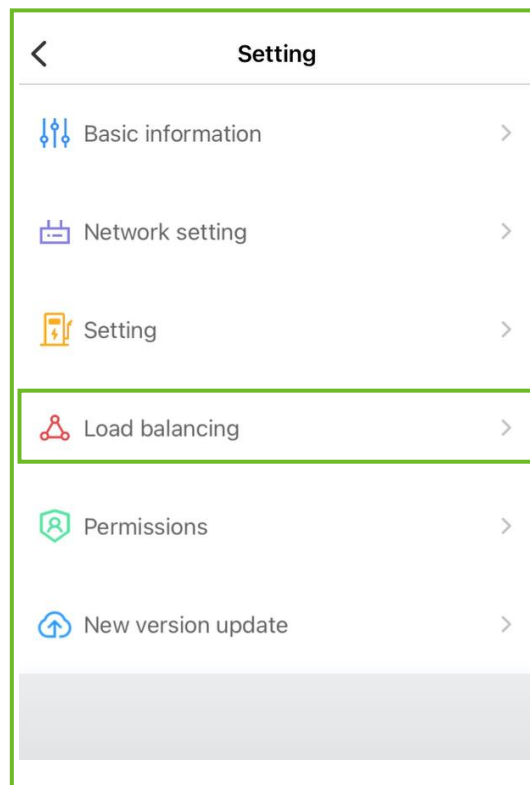

Choose Load balancing

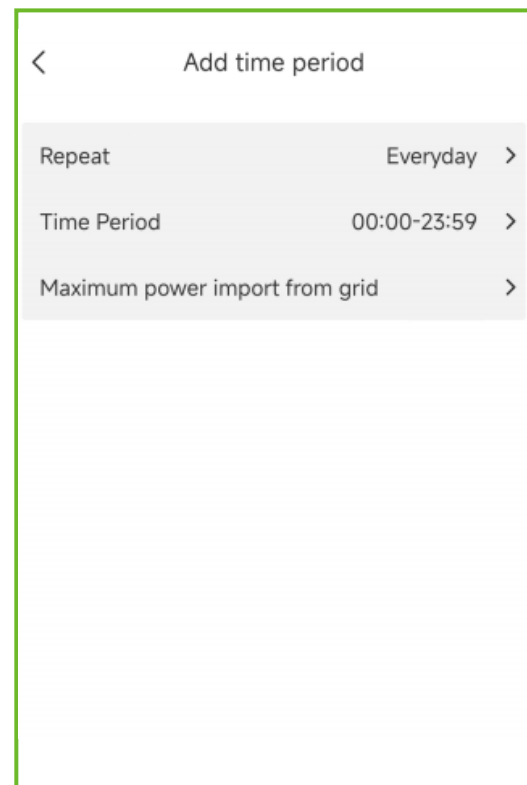

Select the time period and set the Max. power your main panel could bear

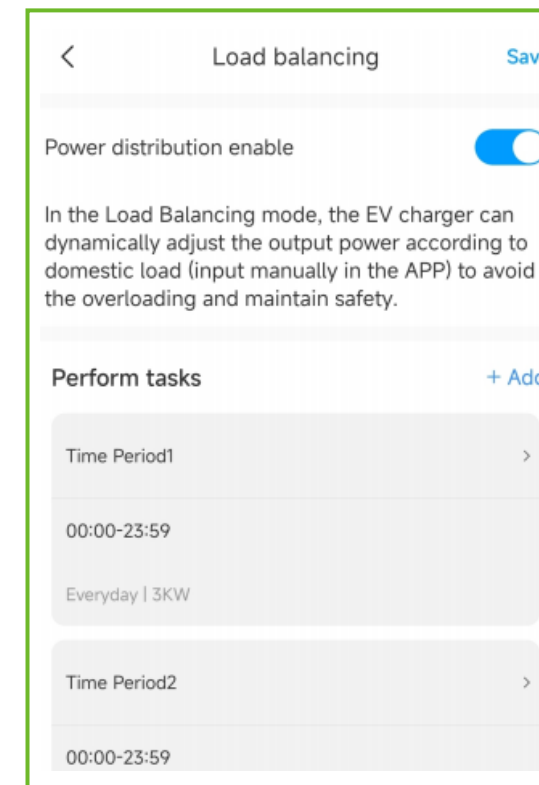

Please note, the load balance function is **not available** in PV linkage mode.

Leading Features – Full Flexibility

Supports three different ways of charging activation, users can define freely for different scenarios. Change the activation way in the Charger setting page.

Plug and Play



Mobile APP



RFID Card



Leading Features – Full Flexibility

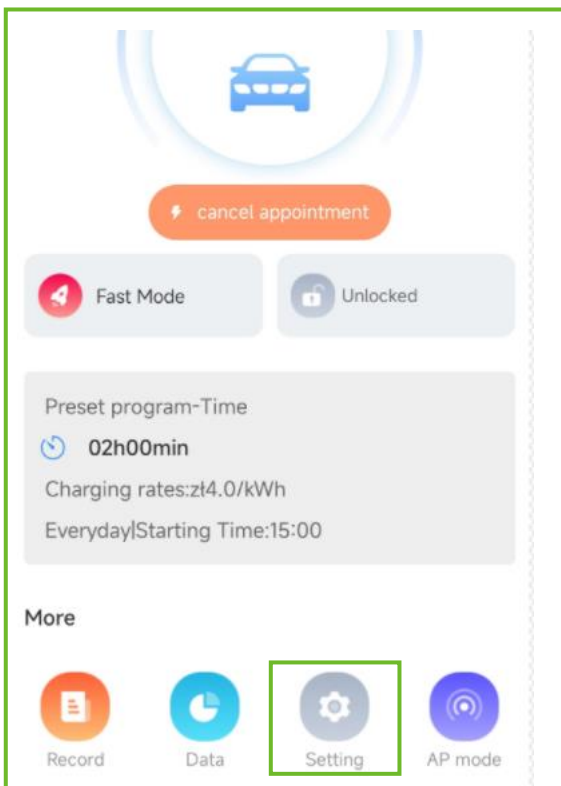

Scroll down and click Setting to enter the setting page.

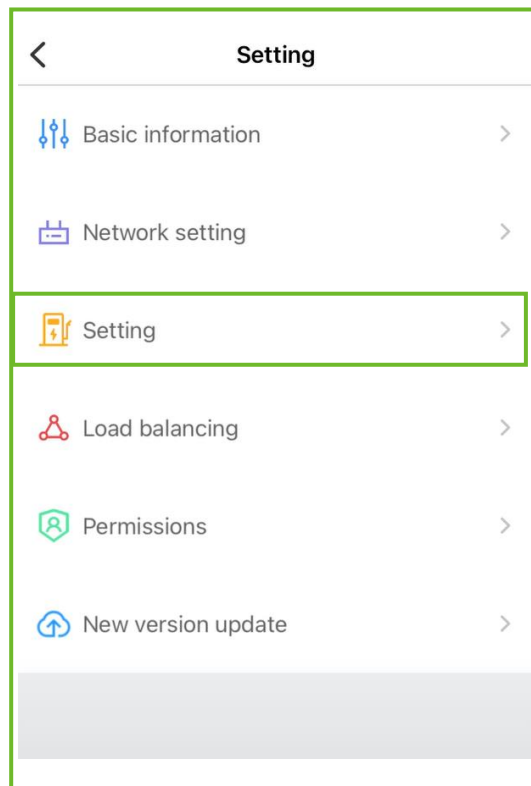

Choose Load balancing

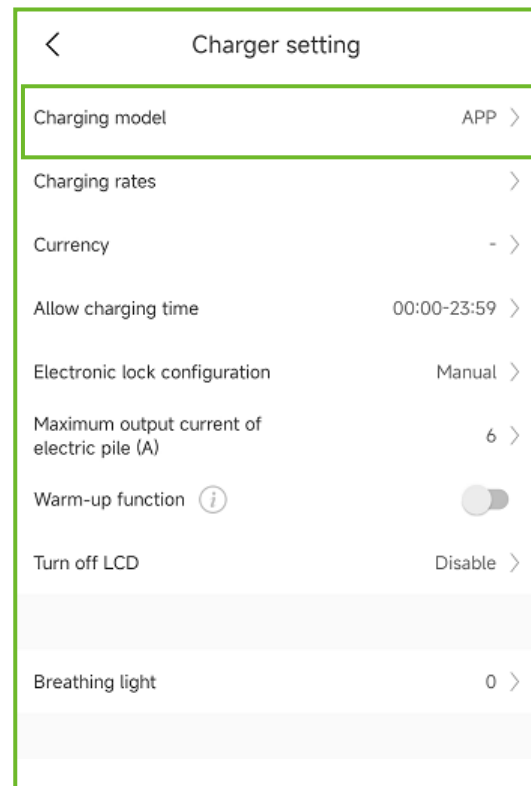

Choose Charge mode

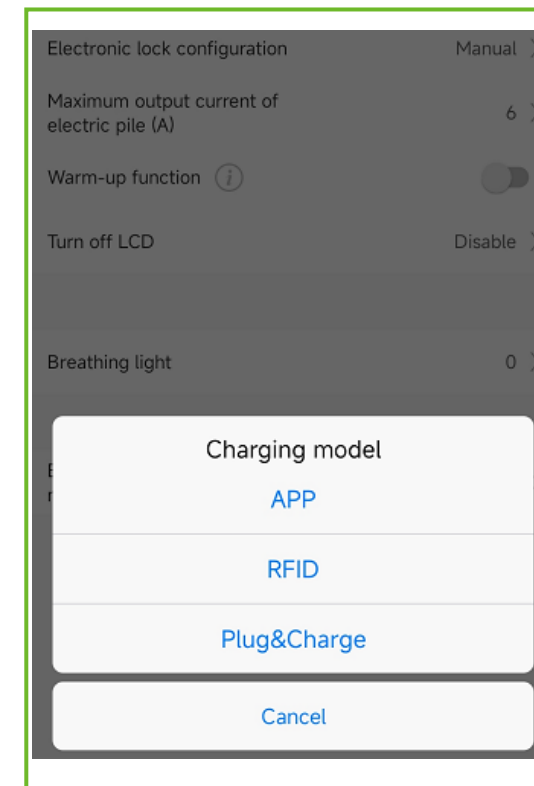

Choose the activation method you want

Other functions

Charger setting	
Charging model	APP >
Charging rates	>
Currency	- >
Allow charging time	00:00-23:59 >
Electronic lock configuration	Manual >
Maximum output current of electric pile (A)	6 >
Warm-up function 	<input type="checkbox"/>
Turn off LCD	Disable >
Breathing light	
	0 >
External current sampling wiring method	
	CT2000 >

- **Charging model:** Change it to change the activation way.
- **Charging rates:** Set it to change the charging rules.
- **Currency:** Set the currency to calculate the charging budget.
- **Allow charging time:** Use it to limit the charging time.
- **Maximum output current of EV charger:** Limit the output power of EV charger.
- **Warm-up function:** Preheat the EV charger when to reduce the battery consumption under the extremely cold whether.

Troubleshooting - No Hotspot Signal

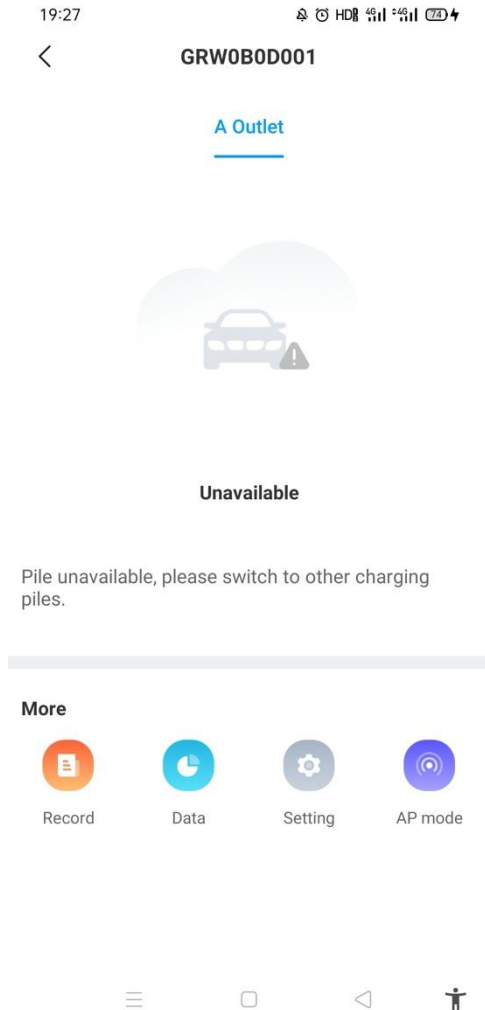

If Shinephone shows that your EV charger is not available and you can not find the Hotspot shared by your EV charger, please power off your EV charger and restart the EV charger.

The Hotspot signal will last a few minutes after you power it on again.

Troubleshooting - Offline

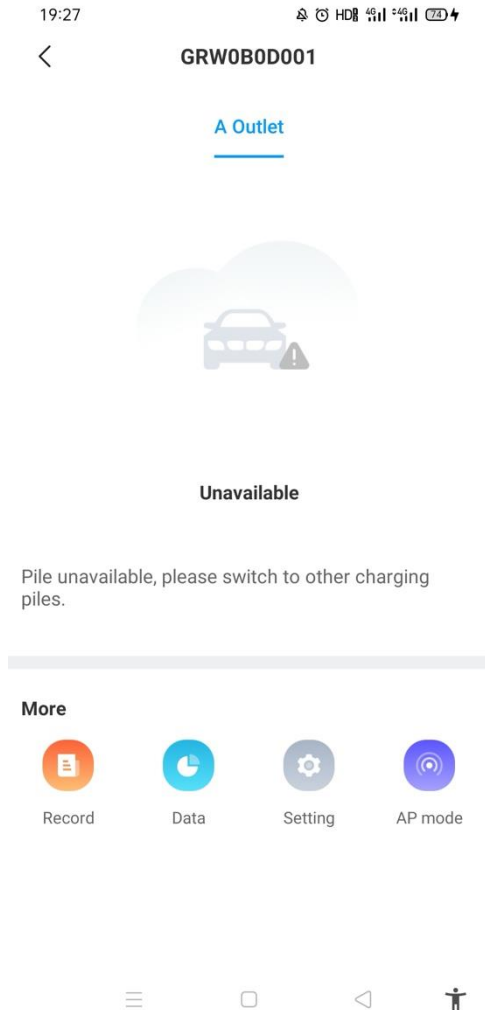

If Shinephone shows that your EV charger is not available, it means that your EV is offline and need to be reconnected to internet.

- Please click the AP mode.
- Connect your phone to the hotspot whose name is consistent with the EV charger's SN.
- Enter the name and password of your router.
- Wait for 2~5 minutes to see if the network connection is successful.

System Startup

Before power on, please make sure all the voltage and current are in the range of specification of hybrid inverter. Otherwise, it will be damage to hybrid inverter.

Follow are the steps of turn on actions:

1. Turn on the switch between Grid and hybrid inverter.
2. Turn on battery and the switch between battery and hybrid inverter.
3. Turn on PV switch. And then turn on switch between PV and hybrid inverter. **Please don't turn on PV switch of inverter under PV voltage, that can damage the inverter.**
4. If need to setup hybrid inverter. Please turn to user manual of hybrid inverter for detail description.
5. The shutdown steps are opposite to the above order.

Commercial WIT 28-55K & 50-100K





WIT 28-55K-US L2
WIT 50-100K-US

WIT+APX System

- **Nominal Output Power:**
 - 28-55kW (208Vac)
 - 50-100kW (480Vac)
 - **Nominal AC Frequency:** 60Hz
 - **Battery Energy:** 86-200kWh
 - **PV Energy:** 2x Output Power – Up to 10 MPPTs, 2 Strings/MPPT
 - **AC Grid Connection Type:** 3P3W+PE / 3P4W+PE
 - **Ingress Protection:** IP66
 - **Working Modes:** On-grid & Off-Grid
 - **On/Off Switching Time:** < 20ms(HU/AU Model)
 - **Installation Method**
 - Floor (Inverter)
 - Stacked (battery)
 - **Parallel System :**
 - 6 sets (On-Grid mode)
 - 3 sets(Off-Grid mode)
 - **Warranty:** 10-year standard (Inv. 15/20 yr. options)
-
- **Certifications**
 - UL1741 (SA/SB)
 - UL9540A
 - UL9540
 - CSA C22.2 107.1
 - CSA 22.3 No 9 (In progress)

System Composition

1. Hybrid/storage Inverter
2. Battery system
- 3.AC Combiner Box
4. SEM-X(Smart Manager Center) / Datalogger
- 5.Solar panel

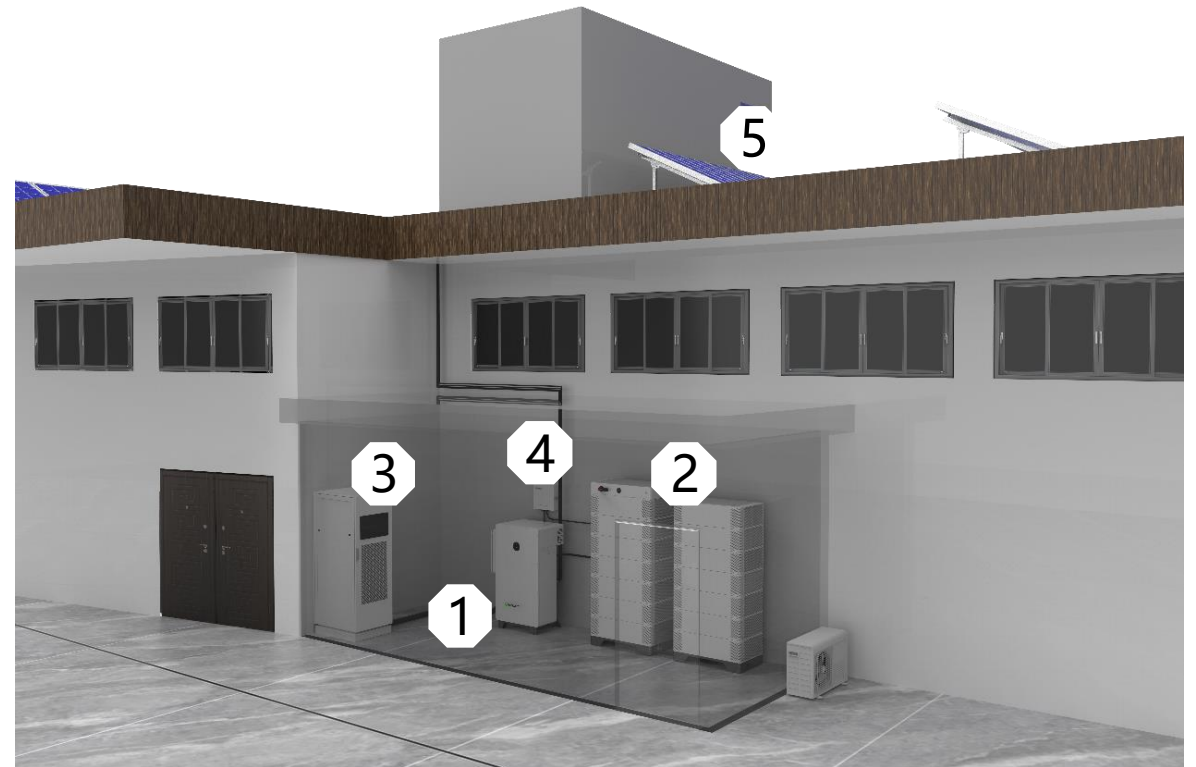
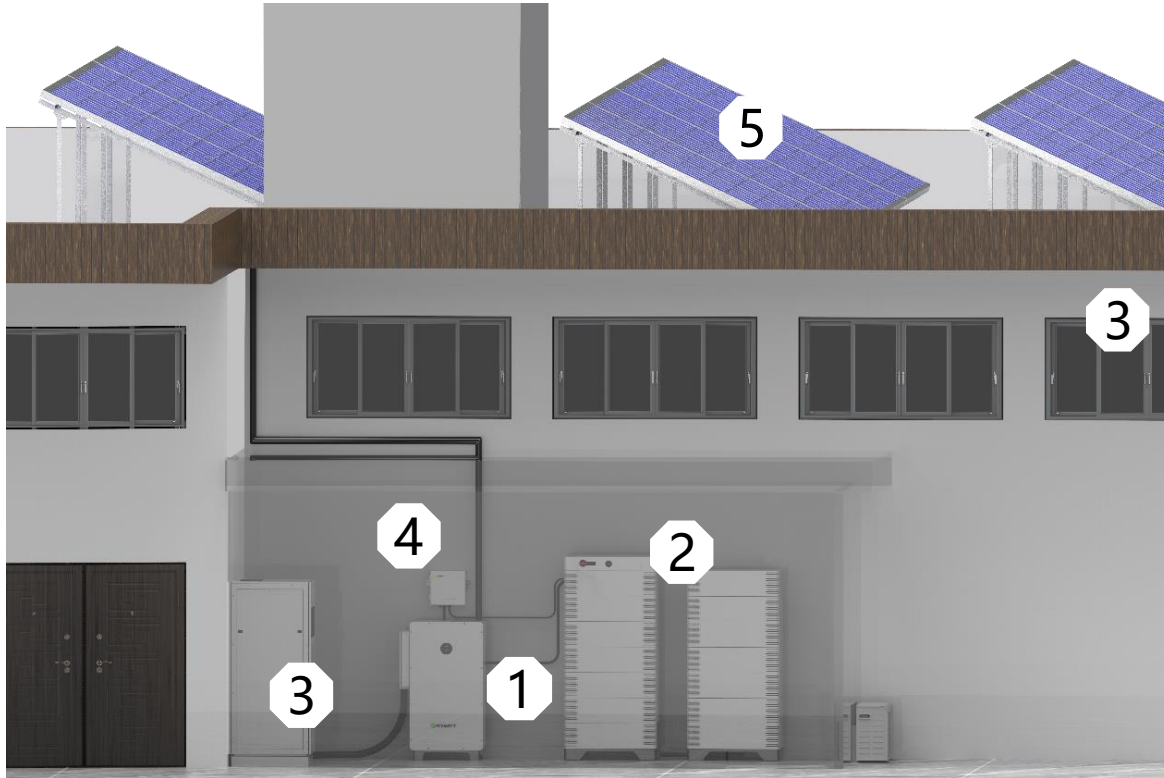

The system supports indoor and outdoor installation, outdoor installation requires adding sunshades to avoid direct sunlight.

A mild environment helps extend the lifespan of the system, when the ambient temperature exceeds **30°C**, the discharge time will be limited at full power output.

- **Self-Consumption:** Storing the surplus solar power into the battery during the day and using it at night, which maximizes the solar energy self-consumption rate.

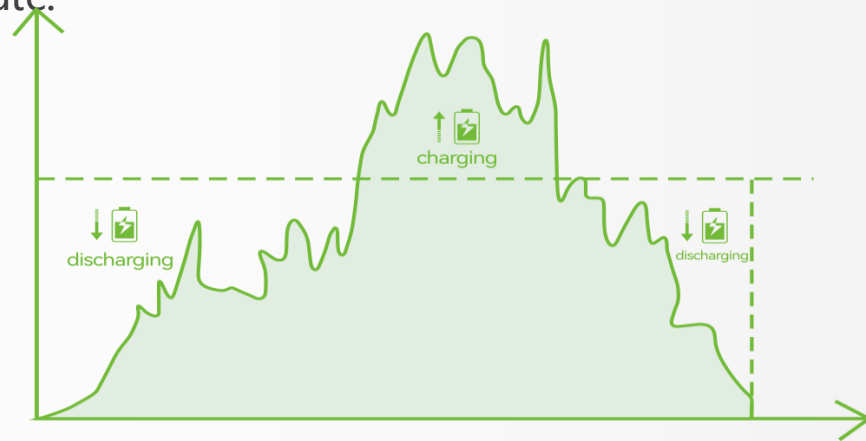

- **Time of Use:** Charge the battery at off-peak tariff and use it at peak tariff to reduce the electricity bill.

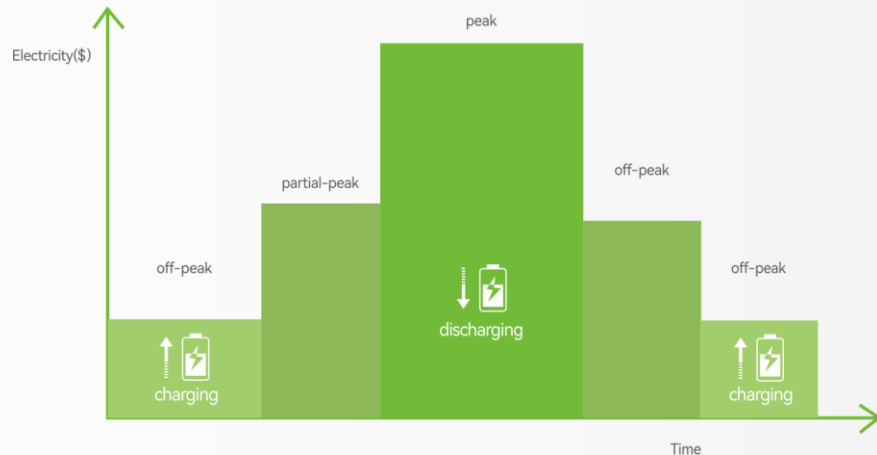

- **Peak Shaving:** Discharging at peak load and charge the battery at off-peak load.

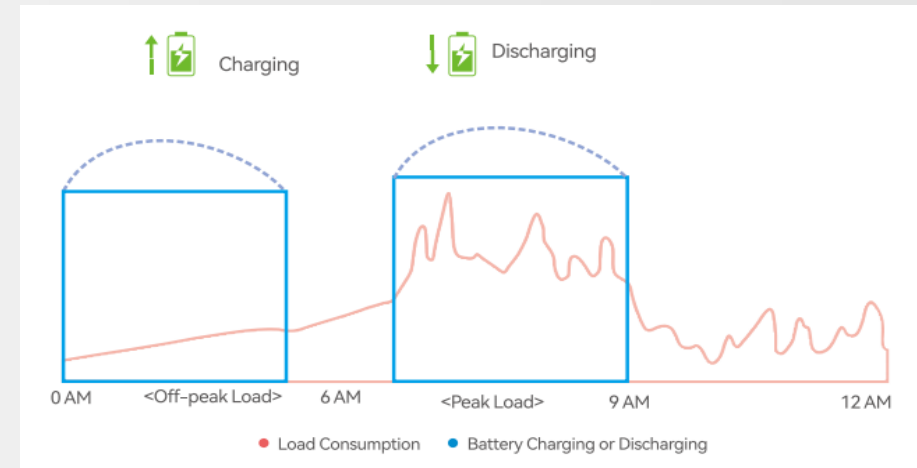

- **Zero Export:** Manage export/import limitations via password protected online portal.

Set Exportlimit ▲

Set Exportlimit Enable Meter 1 ▼

Export Limitation Power % for Single Inverter [-100.0,100.0]%

- **Power Expansion:** The battery will discharge to compensate for the additional load consumption when the load power exceeds the transformer capacity.

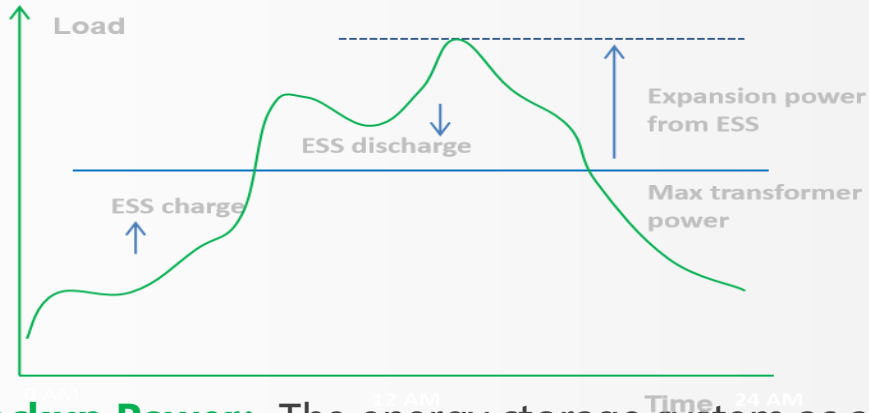

- **Backup Power:** The energy storage system as a backup power will supply power to the load when the power grid fails.

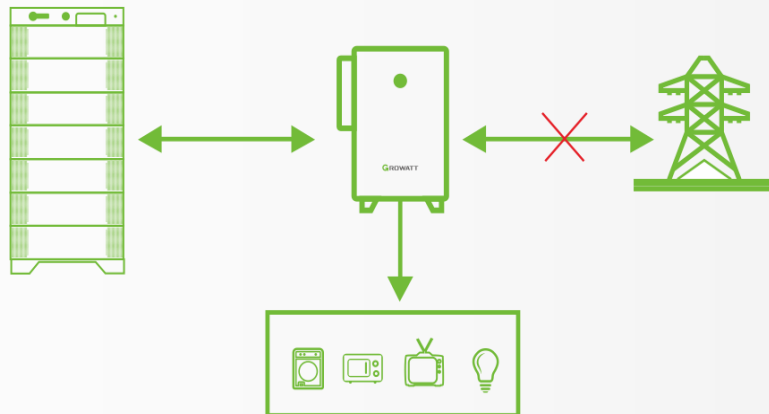

- **Micro-grid:** Work with multiple energy source to guarantee 24/7 power supply where there is no grid.

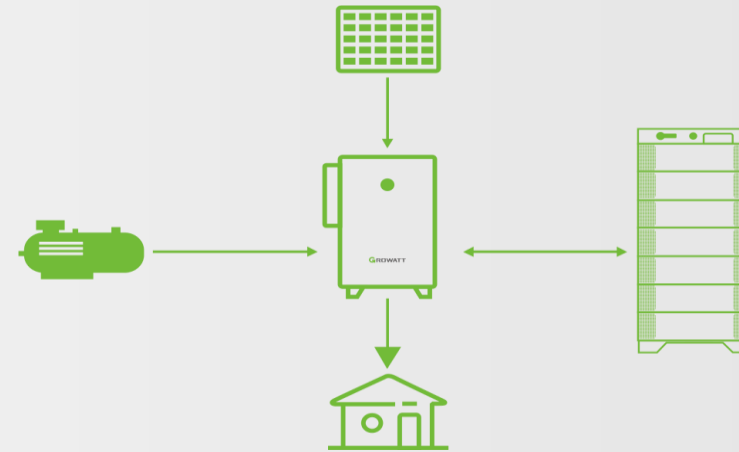

- **Power Quality:** A battery inverter with a power quality function balances fluctuations in the mains voltage, thus ensuring that facilities have consistently high mains quality and therefore operate safely.

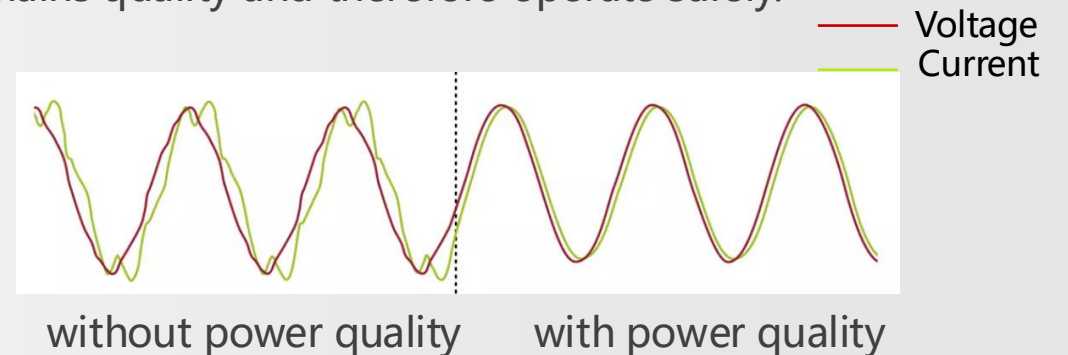

Distributed, Simple and Standard Solution

Redefined the commercial energy storage system by a distributed, simplified and standard product rather than a complex system combination, helping the customer to realize quick design, installation and configuration

Traditional Solution

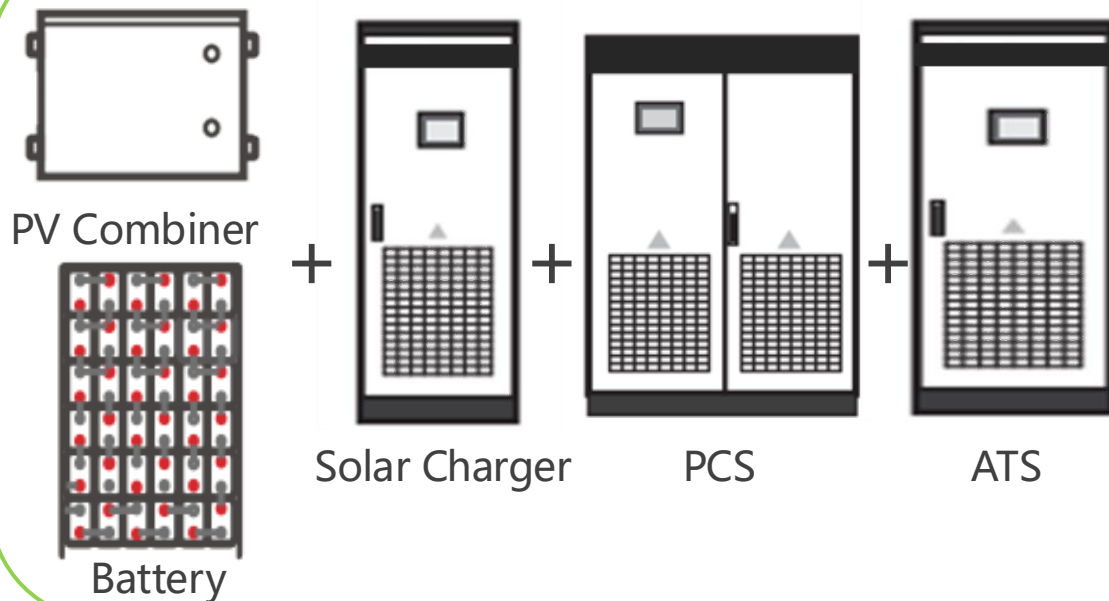

VS

Growatt Solution

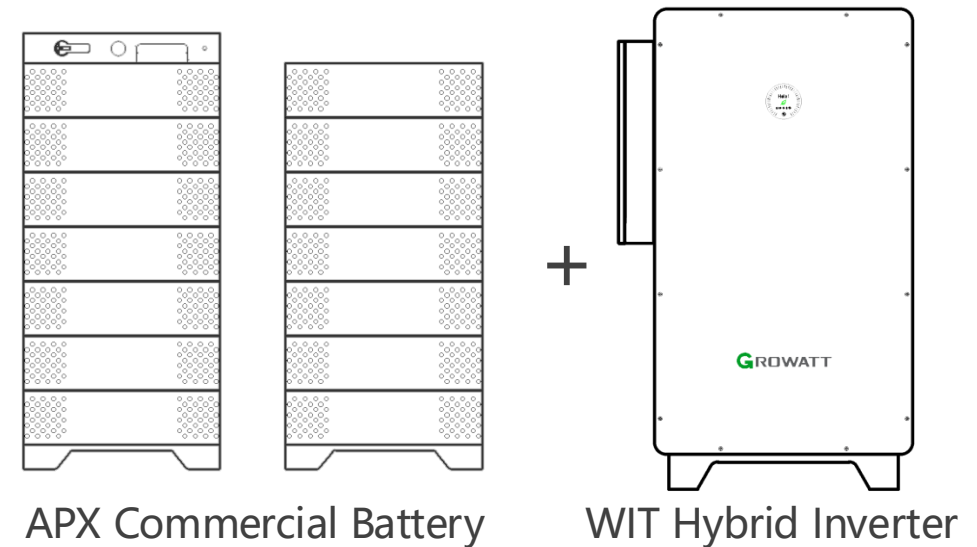

Single System Communication Topology

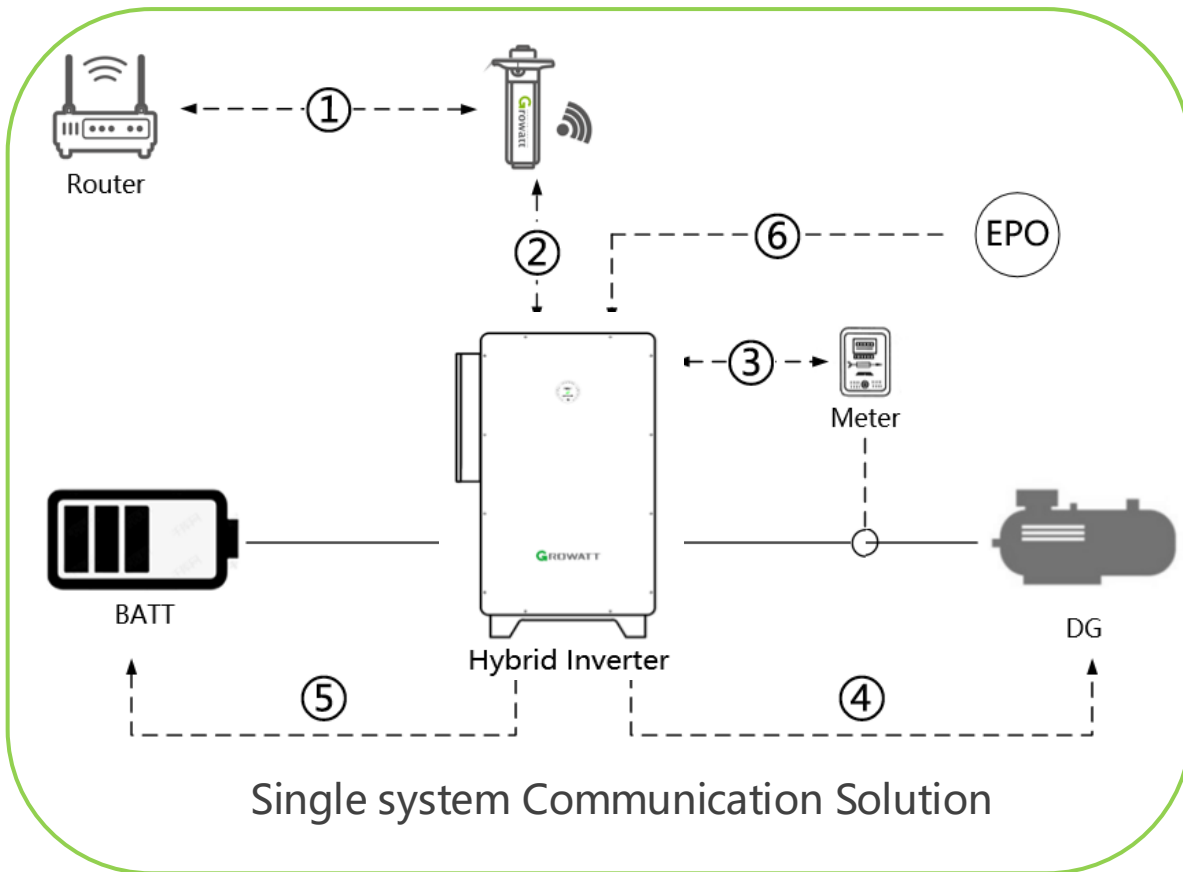

No	Communication	Connection	Function
①	LAN/WIFI/4G	Network	Local or Cloud Platform connection
②	RS485/USB	Datalogger and hybrid/storage inverter	Datalogger built-in WIT
③	RS485	Hybrid/storage inverter and Smart meter	Power flow information and export limit function
④	Dry Contact	Hybrid/storage inverter and Generation	Generator start up and stop
⑤	CAN/RS485	Hybrid/storage inverter and Battery	Battery system communication and control
⑥	DI	EPO	Emergency Stop

480V System Options				
APX 200.7H-S1 200kWh	√	√	√	√
APX 186.3H-S1 186kWh	√	√	√	Limited, 92kW(Max)
APX 172.0H-S1 172kWh	√	√	√	Limited, 85kW(Max)
APX 157.6H-S1 157kWh	√	√	√	Limited, 78kW(Max)
APX 143.3H-S1 143kWh	√	√	Limited, 71kW(Max)	
APX 129.0H-S1 129kWh	√	√	Limited, 64kW(Max)	
Battery	WIT 50K-US	WIT 63K-US	WIT 75K-US	WIT 100K-US
Inverter				
220V/208V System Options				
APX 114.6H-S1 114kWh	√	√	√	√
APX 100.3H-S1 100kWh	√	√	√	Limited, 50kW(Max)
APX 86.0H-S1 86kWh	√	√	√	Limited, 43kW(Max)
Battery	WIT 28K-US L2	WIT 35K-US L2	WIT 40K-US L2	WIT 55K-US L2
Inverter				

(1) Labeled with "√" means the system can have a full load AC output when only battery, and labeled with "Limited" means the AC max output of the system with corresponding battery system.

- **Self-Consumption:** Storing the surplus solar power into the battery during the day and using it at night, which maximizes the solar energy self-consumption rate.

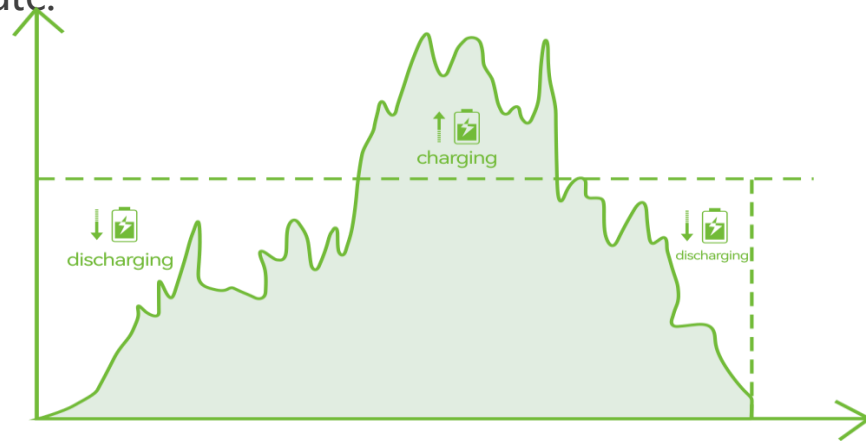

- **Time of Use:** Charge the battery at off-peak tariff and use it at peak tariff to reduce the electricity bill.

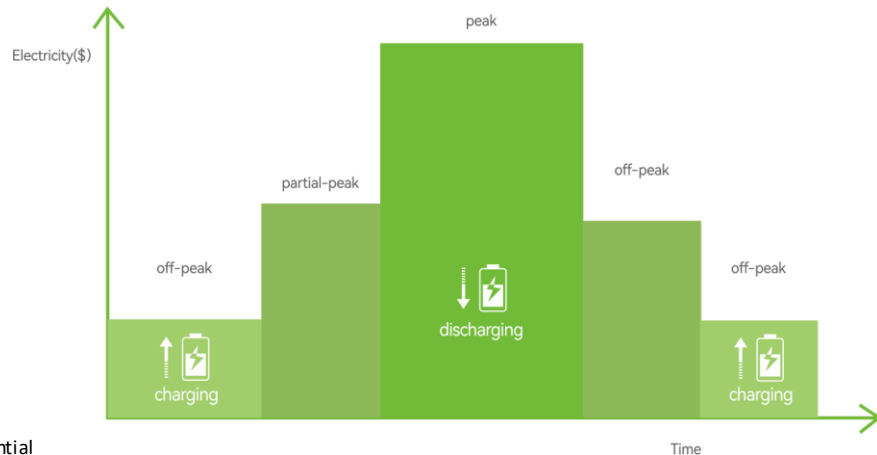

- **Peak Shaving:** Discharging at peak load and charge the battery at off-peak load.

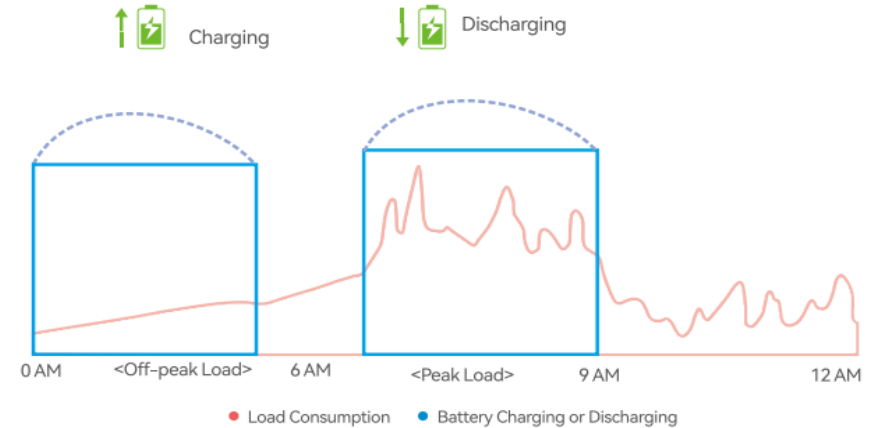

- **Zero Export:** Manage export/import limitations via password protected online portal.

Set Exportlimit ▲

Set Exportlimit Enable Meter 1 ▼

Export Limitation Power % for Single Inverter [-100.0,100.0]%



Higher Yields

- ★ Up to 2.0 Ratio DC/AC
Max. efficiency 98%
String current 16A for high power
- ★ modules
10 MPPTs, 20 strings per inverter
Build-in PID recovery function



Safe and Reliable

- Fuse free design
- IP66 protection degree
- Type II SPD on DC&AC side
- Active ARC protection (AFCI)



AC Power Ability

- 100% unbalanced load when backup
- ★ 110% continuous AC overloading capacity
Scalable up to 300kW in off-grid application



Smart

- Intelligent string monitoring
- Smart IV curve scanning
- One-click-diagnosis
- Remote online maintenance

Ultimate User Experience

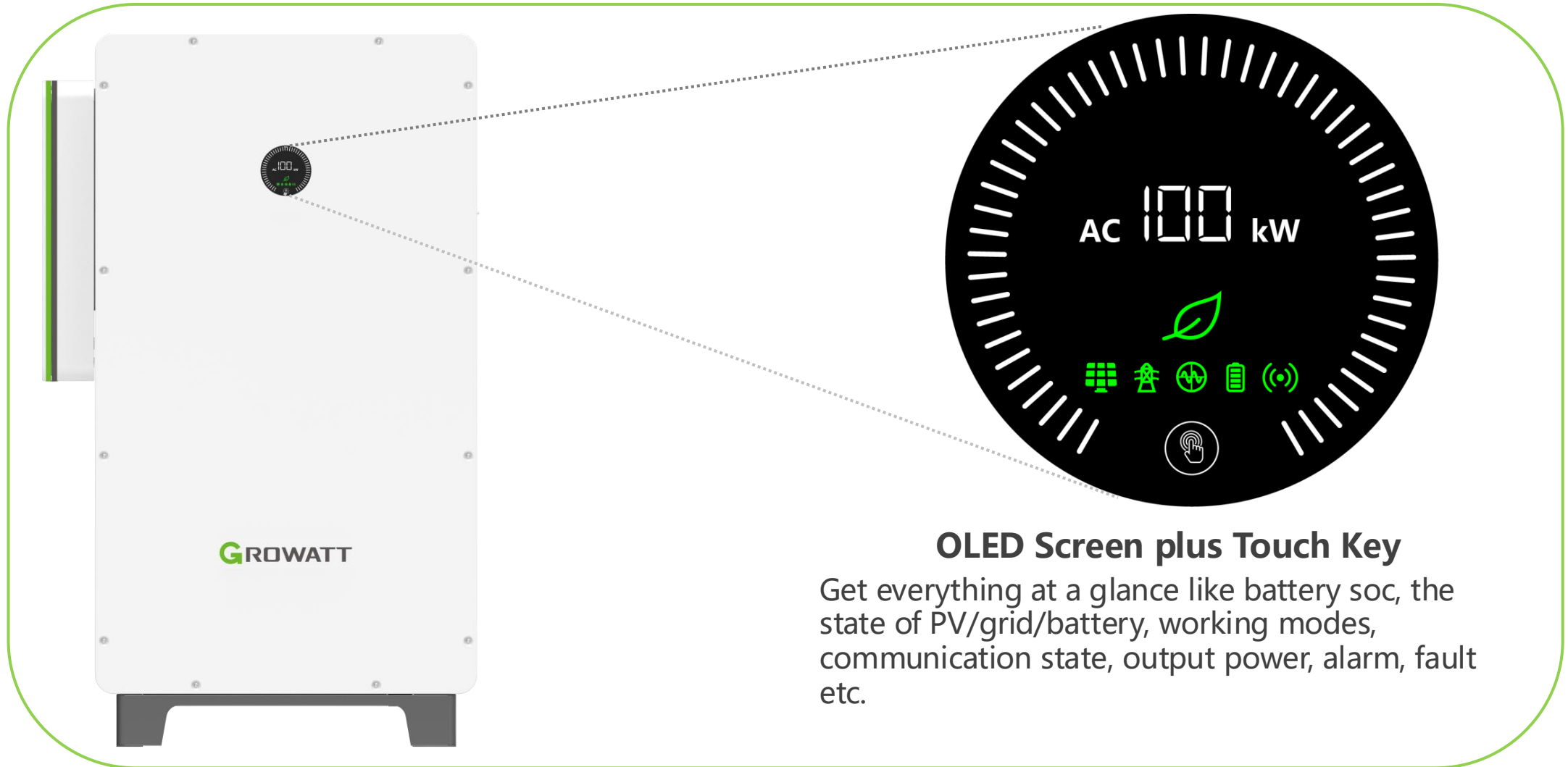

OLED Screen plus Touch Key

Get everything at a glance like battery soc, the state of PV/grid/battery, working modes, communication state, output power, alarm, fault etc.

Easy Installation and Handling



High Protection AC Connection Box

Enough space for connection from bottom to up, meeting ground groove and bent wire groove

Telescopic Handle

Meeting manual lifting, hiking up for moving

Signal Connection Centralized Area

The signal lines are arranged in a centralized area, which is convenient for cable deployment

Horizontal Ventilation Design

Avoid long-term dust accumulation effectively

High Protection Plug-in DC Connection

Easier and quicker installation

- **Power Expansion:** The battery will discharge to compensate for the additional load consumption when the load power exceeds the transformer capacity.

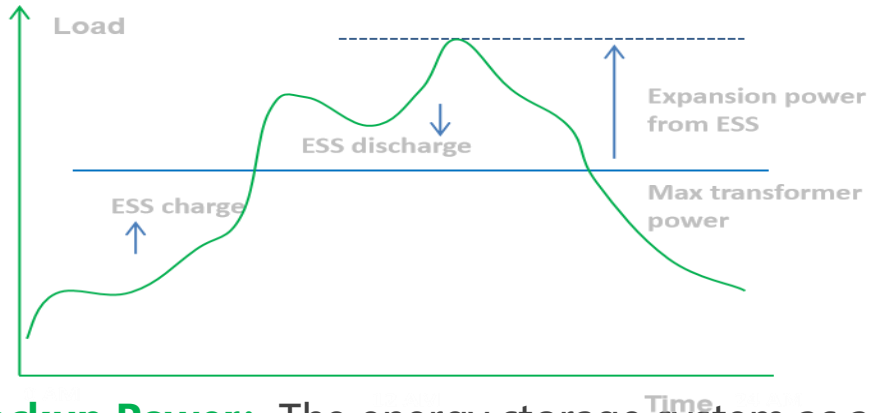

- **Backup Power:** The energy storage system as a backup power will supply power to the load when the power grid fails.

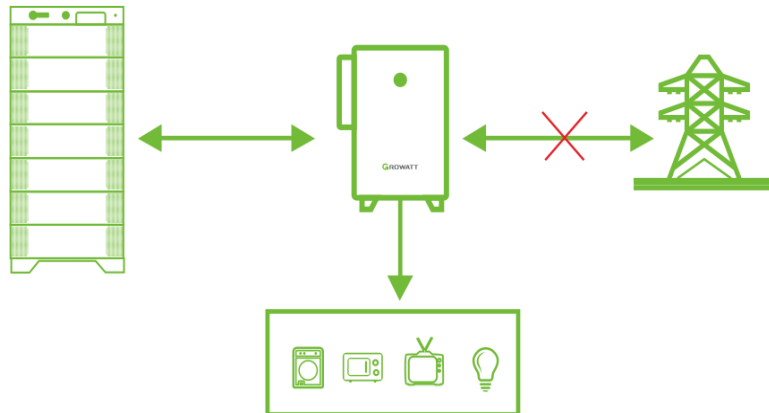

- **Micro-grid:** Work with multiple energy source to guarantee 24/7 power supply where there is no grid.

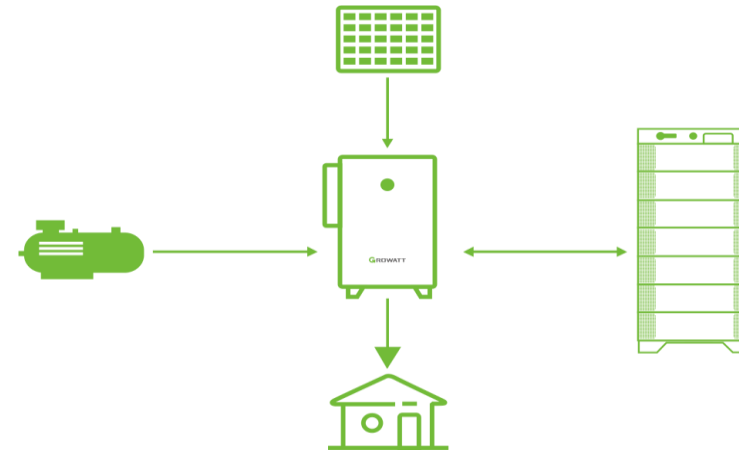

- **Power Quality:** A battery inverter with a power quality function balances fluctuations in the mains voltage, thus ensuring that facilities have consistently high mains quality and therefore operate safely.



Whole System Warranty



Complete Equipment Supply

Inverter, Lithium Battery, ATS and
Monitoring

Whole System Guarantee

Guidance and help of the whole system,
Warranty for all devices,
Professional and local service team

Recommended Solution for C&I Application Scenarios

TOU Applications – Peak Shaving – Self-Consumption – Zero-Export
Small systems with stable loads that want to maximize profit

Hybrid ESS for On-grid Solution (Single System)

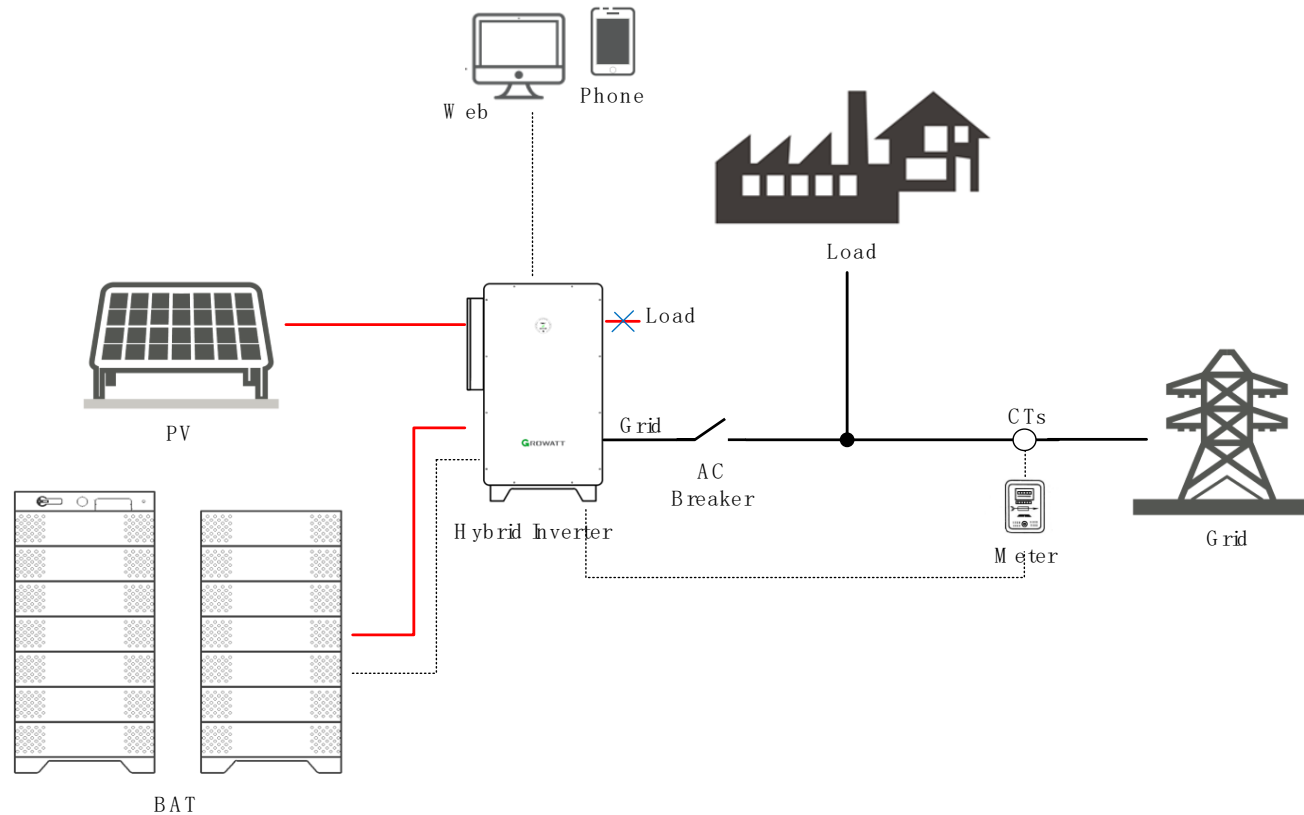

System Composition

- **Inverter:**
 - WIT 28-55K-HU-US L2
 - WIT 50-100K-HU-US
- **BAT:**
 - APX 86-200H-S1-US
- **EMS:**
 - Meter+3CTs
- **Monitoring:**
 - Built-in datalogger (WiFi/Lan or WiFi/4G)

Recommended Solution for C&I Application Scenarios

TOU Applications – Peak Shaving – Self-Consumption – Zero-Export
Larger systems with stable loads that want to maximize profit

Hybrid ESS for On-grid Solution Multiple System in Parallel

System Composition

- **Inverter:**
 - WIT 28-55K-HU-US L2
 - WIT 50-100K-HU-US
- **BAT:** APX 86-200H-S1-US
- **EMS:**
 - SEM-X-RM with 3CTs
- **Monitoring:**
 - Built-in datalogger (WiFi/Lan or WiFi/4G)
- **Paralleling:**
 - 6 Inverters Max

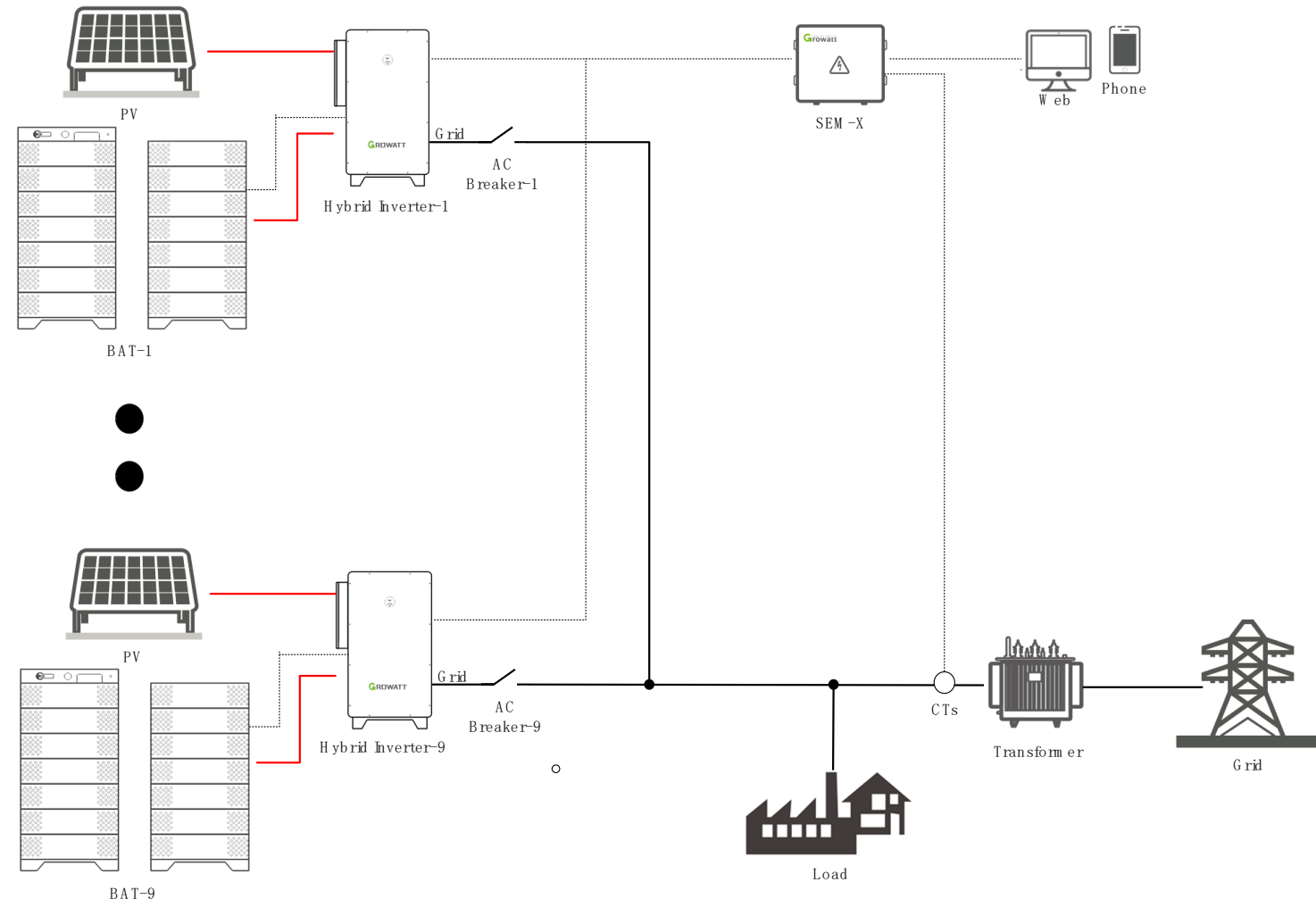

Recommended Solution for C&I Application Scenarios

**TOU Applications – Peak Shaving – Self-Consumption – Zero-Export
+ UPS on critical loads**

**Small systems with equipment that must stay online after grid outages
(for the duration of battery life)**

Hybrid ESS for On/Off-grid Solution Single system (without DG)

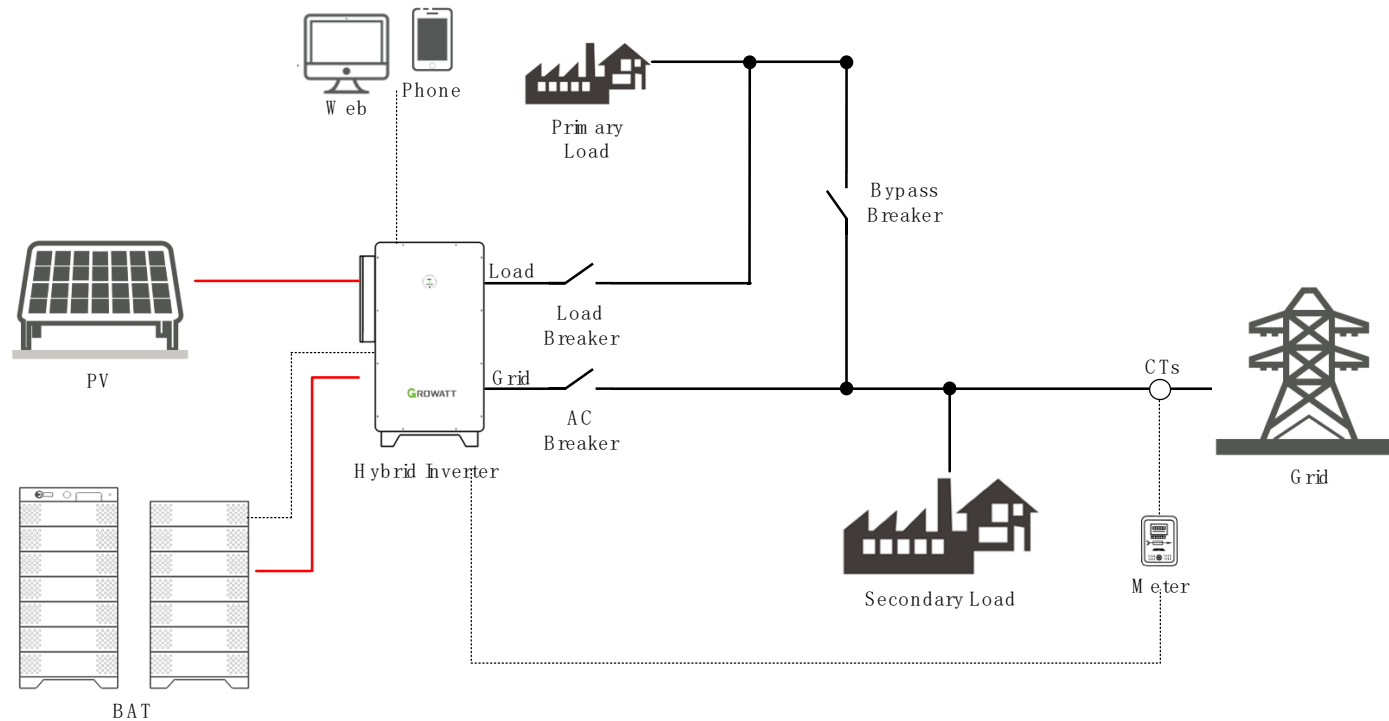

System Composition

- **Inverter:**
 - WIT 28-55K-HU-US L2
 - WIT 50-100K-HU-US
- **BAT:**
 - APX 86-200H-S1-US
- **EMS:**
 - Meter+3CTs
- **Monitoring:**
 - Built-in datalogger (WiFi/Lan or WiFi/4G)

Recommended Solution for C&I Application Scenarios

**TOU Applications – Peak Shaving – Self-Consumption – Zero-Export
+ UPS on critical loads**

**Larger systems with equipment that must stay online after grid outages
(for the duration of battery life)**

Hybrid ESS for On/Off-grid Solution Multiple system (without DG)

System Composition

- **Inverter:**
 - WIT 28-55K-HU-US L2
 - WIT 50-100K-HU-US
- **BAT:** APX 86-200H-S1-US
- **EMS:**
 - SEM-X-RM with 3CTs
- **Monitoring:**
 - Built-in datalogger (WiFi/Lan or WiFi/4G)
- **Paralleling:**
 - 3 Inverters Max

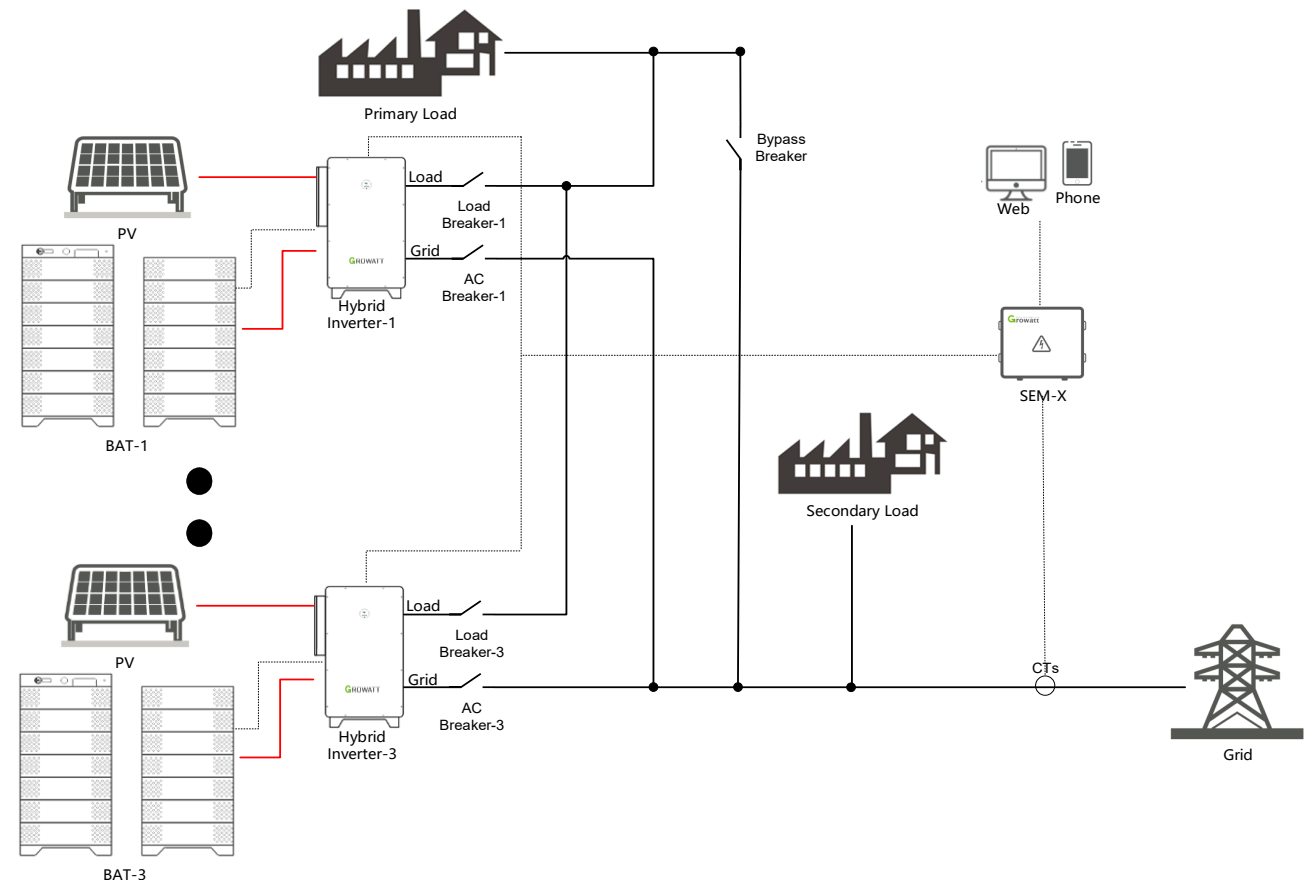

Recommended Solution for C&I Application Scenarios

**TOU Applications – Peak Shaving – Self-Consumption – Zero-Export
+ UPS on critical loads**

**Systems with mission critical equipment that must stay online 24/7
regardless of grid status or battery SOC.**

Hybrid ESS for On/Off-grid Solution Single system (with DG)

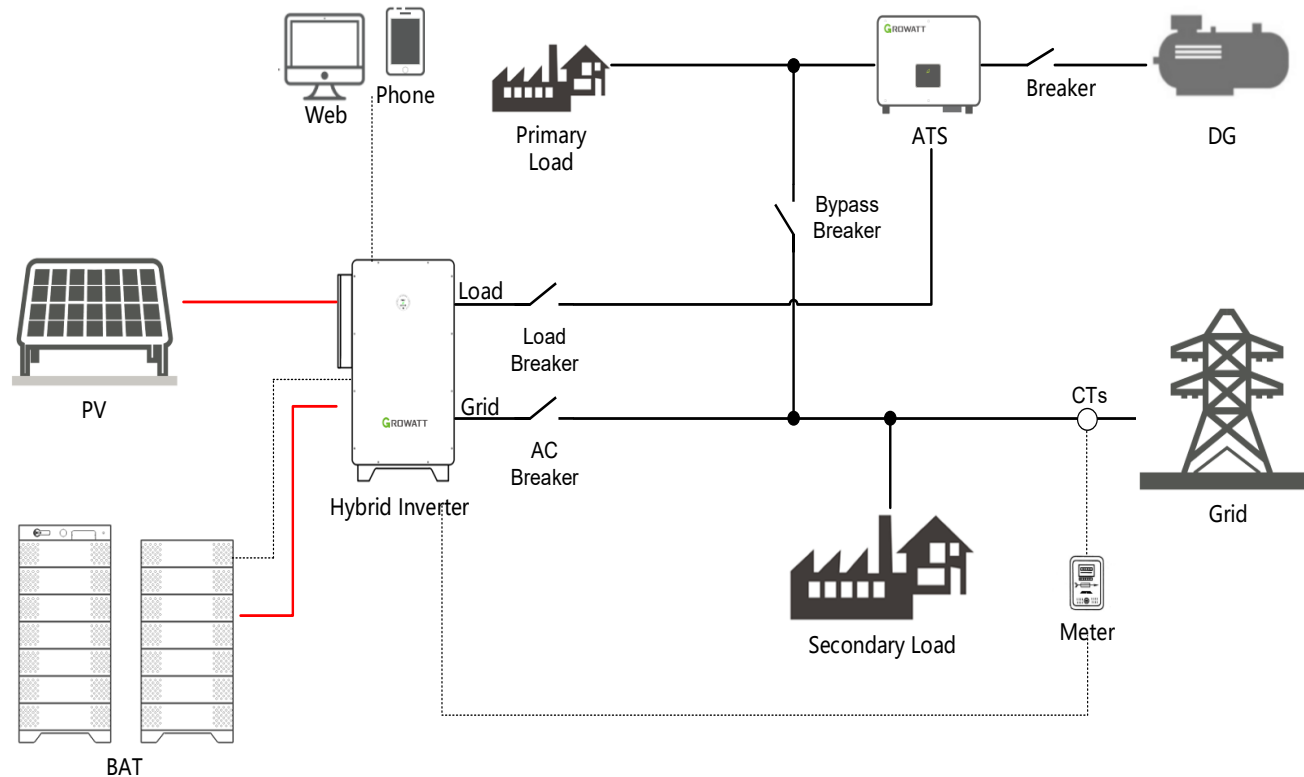

System Composition

- **Inverter:**
 - WIT 28-55K-HU-US L2
 - WIT 50-100K-HU-US
- **BAT:**
 - APX 86-200H-S1-US
- **EMS:**
 - Meter+3CTs
- **Monitoring:**
 - Built-in datalogger (WiFi/Lan or WiFi/4G)
- **Transfer Switch:**
 - ATS
- **DG:**
 - DG must be greater than primary load

Recommended Solution for C&I Application Scenarios

*Microgrid Applications – Small/Large
Off-grid focusing on PV/battery with generator backup as needed.*

Hybrid ESS for Off-grid Solution (Single System With DG)

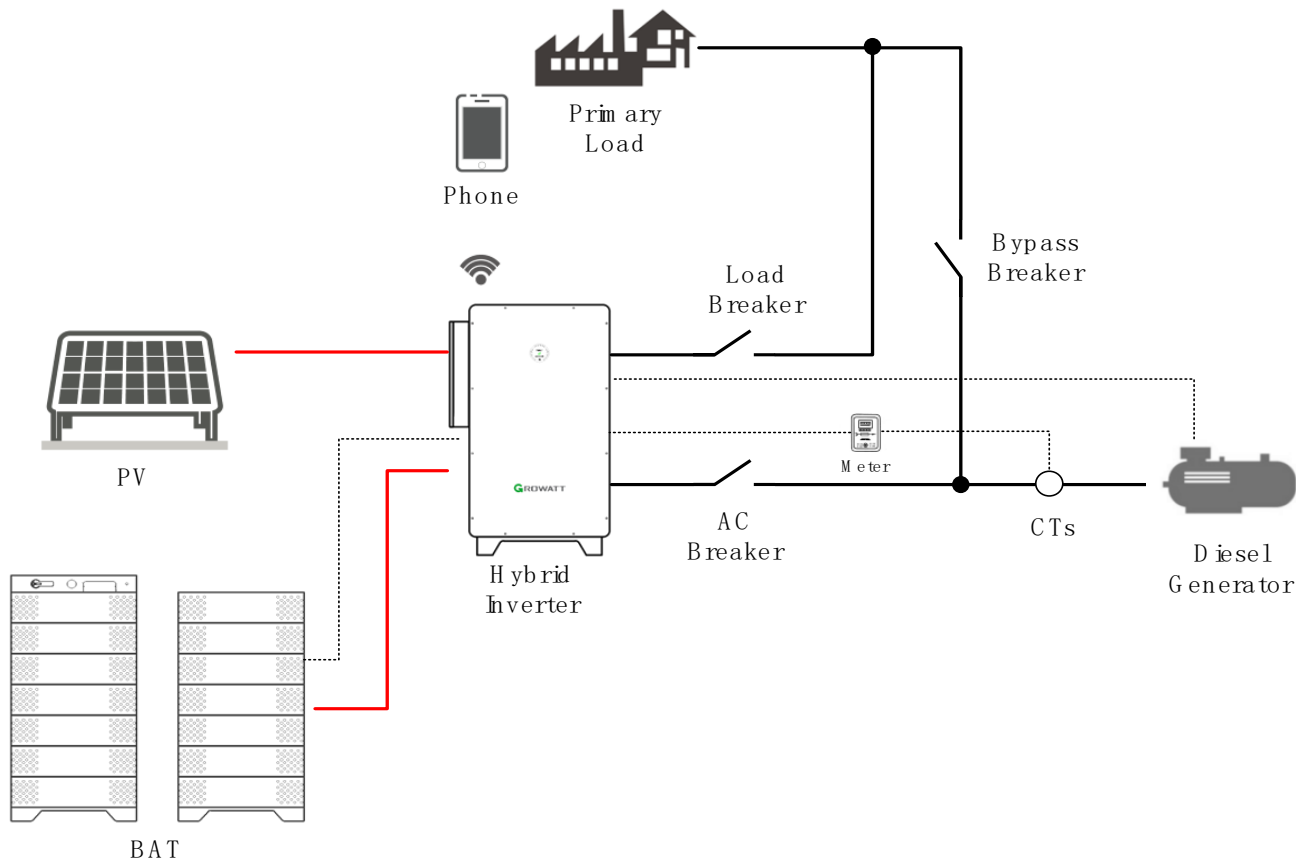

System Composition

- **Inverter:**
 - WIT 28-55K-HU-US L2
 - WIT 50-100K-HU-US
- **BAT:**
 - APX 86-200H-S1-US
- **EMS:**
 - Meter+3CTs
- **Monitoring:**
 - Built-in datalogger (WiFi/Lan or WiFi/4G)
- **Diesel Generator:**
 - DG must be greater than primary load

Hybrid Inverter (HU Model) Topology

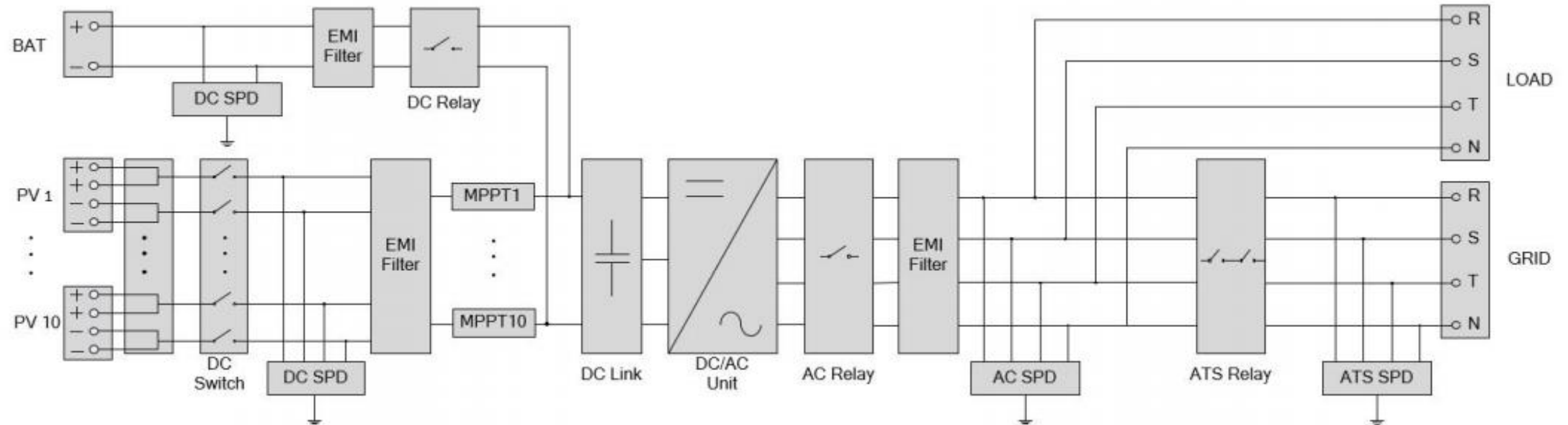

1. The hybrid inverter receives DC inputs from PV strings which go through the MPPT routes. The DC power is then converted into AC power through the inverter circuit to power the loads and feed power into the grid;
2. The PV strings can supply power to charge the battery through the MPPT routes;
3. Convert battery power to AC power supplies for the loads and feeding to the grid;
4. Charge the battery from the grid through a rectifier circuit;
5. Convert the DC power from PV strings and the battery power into AC power through the inverter circuit to power critical loads.

Battery Monitoring

Not only monitor battery system status, but also monitor battery cell security status like temperature, voltage, current



Battery Protection

Provide full-protection for the whole battery system, such as over/under temperature, over/under voltage, over current and short circuit



Redundancy Design

In the event of a battery pack defective, the whole system will not be affected.

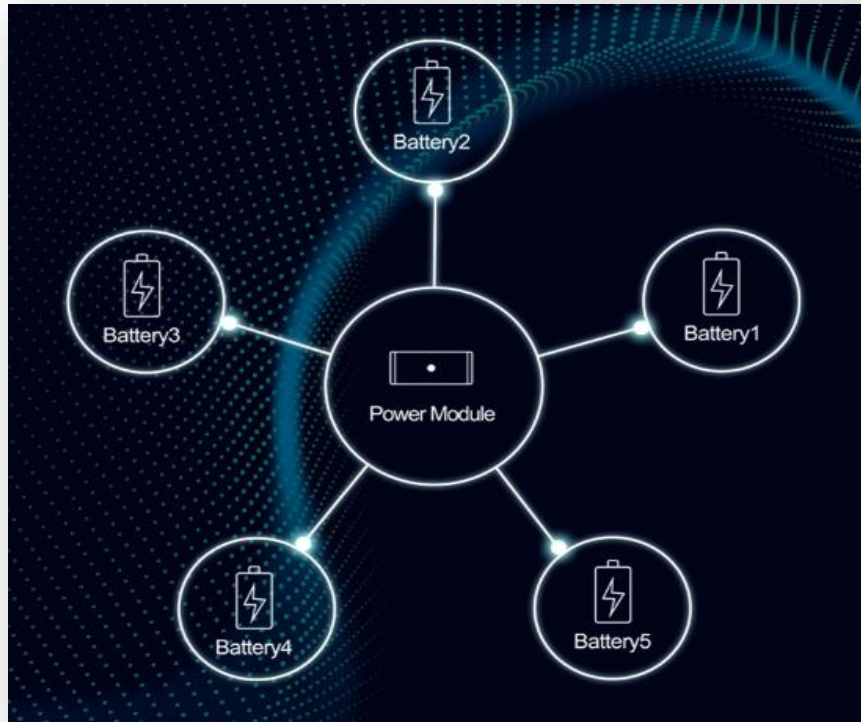

Multiple Level Protection

Active protection by BMS and energy optimizer and passive protection

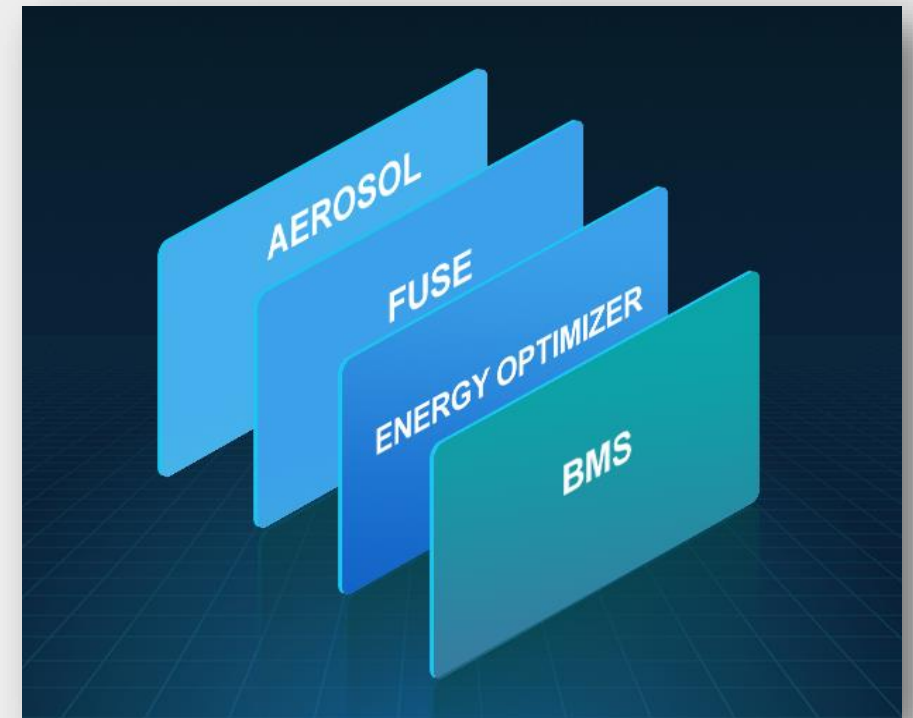

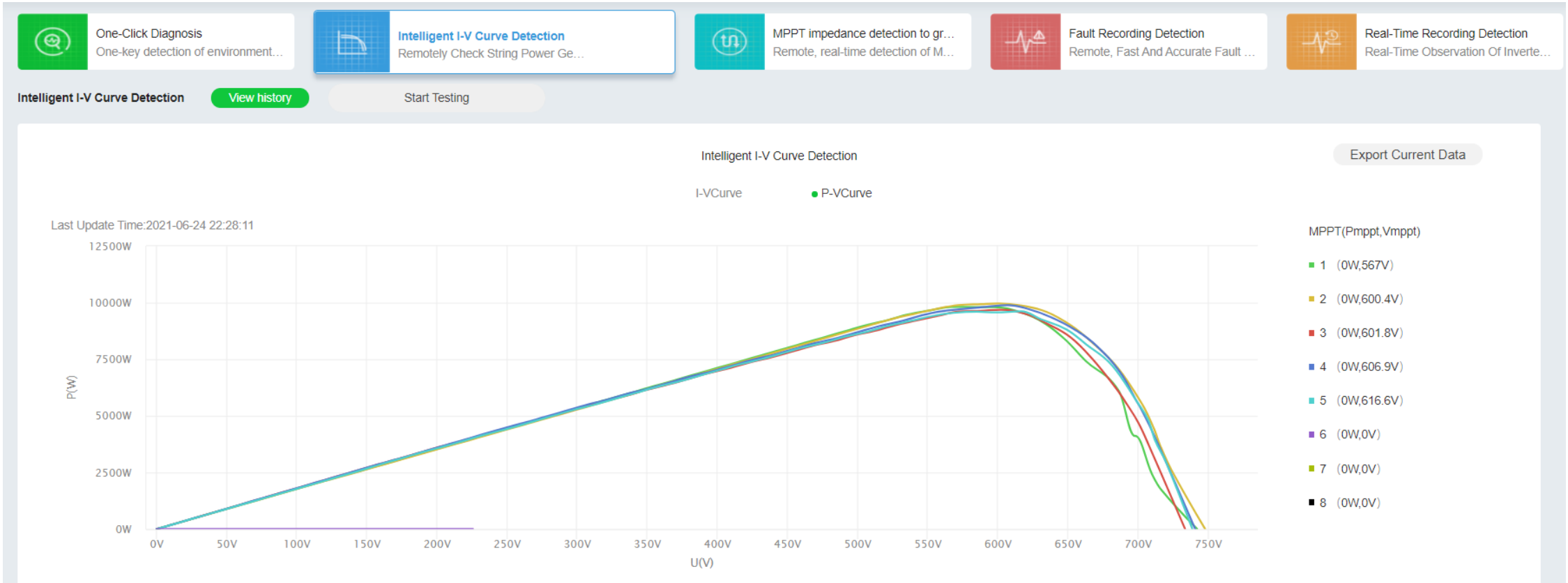

- One-click-diagnosis for solar input side, no need professional people or equipment
- Intelligent I-V curve detection, realizing intelligent operation and maintenance
- Accurate fault location and trouble-shooting guide

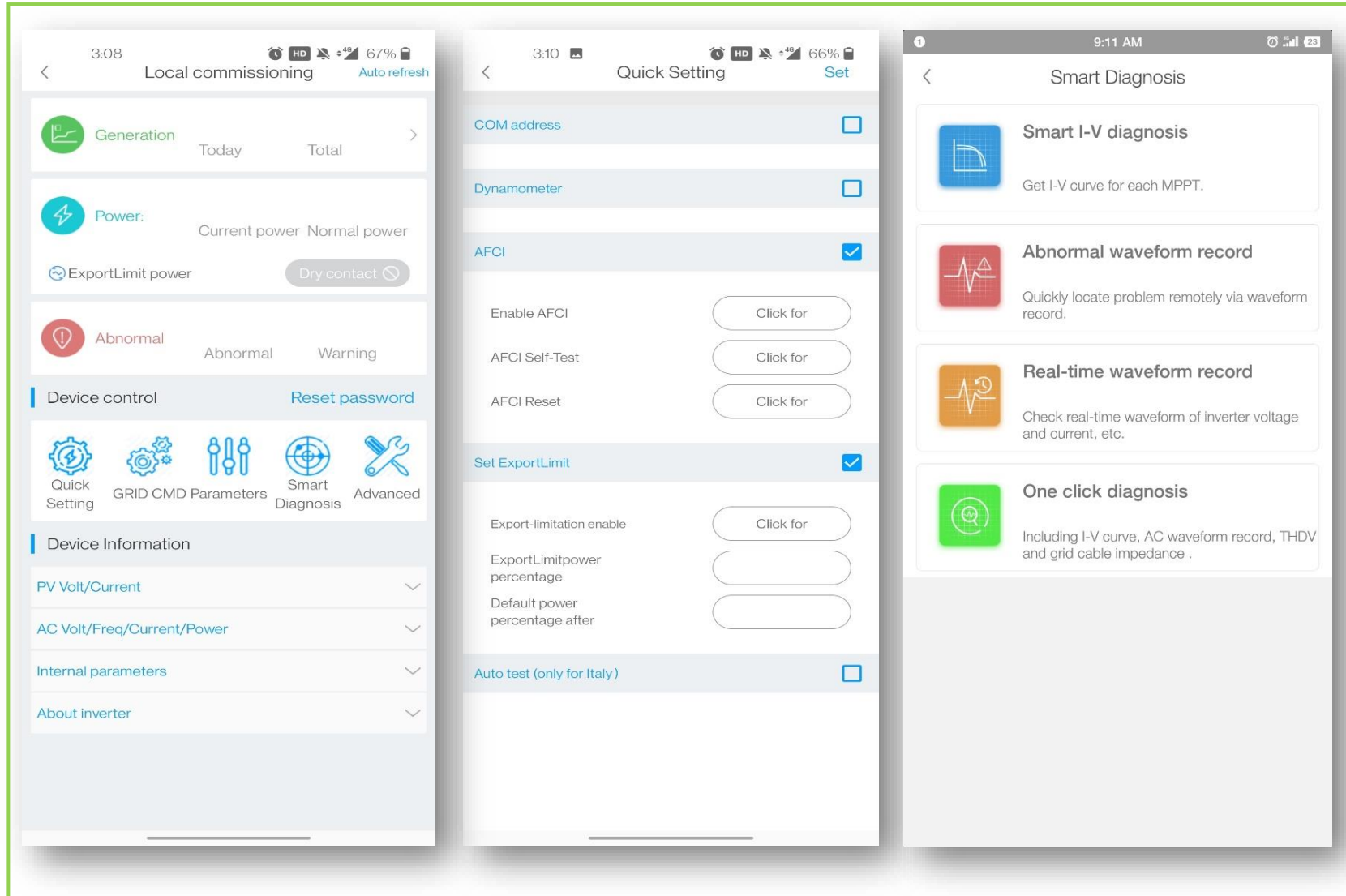

USB-WiFi+ShineTools

Make it easier for local commissioning

For examples, turn on/off AFCI, turn on/off export limitation, I/V curve scanning

Fast and easy, saving cost and time, peace in mind.



Configuration via APP
USB-WiFi+ShinePhone App

Online Smart Service
Remote Firmware upgrade
Remote diagnose and
configuration

System Startup

Before power on, please make sure all the voltage and current are in the range of specification of hybrid inverter. Otherwise, it will be damage to hybrid inverter.

Follow are the steps of turn on actions:

1. Turn on the switch between Grid and hybrid inverter.
2. Turn on battery and the switch between battery and hybrid inverter.
3. Turn on PV switch. And then turn on switch between PV and hybrid inverter. **Please don't turn on PV switch of inverter under PV voltage, that can damage the inverter.**
4. If need to setup hybrid inverter. Please turn to user manual of hybrid inverter for detail description.
5. The shutdown steps are opposite to the above order.

Types of Accounts:

Distributor Account

Call Sales or Support to set up

Installer Account

Create from Distributor account Web Portal
or

Call support to set up on site or beforehand:
1866-686-0298
1866-661-1808

End User Account

Set up by homeowner in Shiner app directly

Shiner Server

Growatt-US.Vidagrid.com

Shine Tools Server

server-us.growatt.com

SHENZHEN GROWATT NEW ENERGY CO.,LTD

Commissioning Applications



SHINER:

MIN + SPH

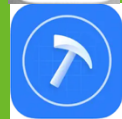

SHINE TOOLS:

WIT

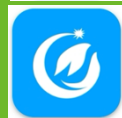

SHINE PHONE:

EV Charger



GROWATT

ShineTools APP Settings Guide

Step 1: Download & Install the ShineTools APP from Android or iOS App Store



ShineTools 4+
Shenzhen Growatt New Energy Technology Co.,Ltd

Deployment mode • diversification
Support multiple provisioning methods

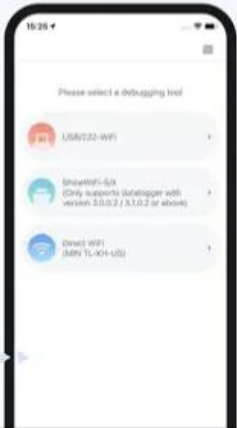

Product commissioning • multi series
Support multi series product debugging



Tutorial • clarity
Clear tutorial



Parameter configuration • simple and safe
Simple and safe parameter setting
Timely grasp the real-time status of equipment



ShineTools APP Settings Guide

Step 2: Add SPH 10000TL-HU-US to online account
And network configuration

<p>Download ShineTools APP from APP store</p>	<p>Open ShineTools APP</p>	<p>Enter OSS account name and password under O&M User.</p>	<p>Click on the menu button and choose Quick Site Setup</p>	<p>Enter end user account information. If user account already setup, click on Skip.</p>	<p>Enter end user Plant information. If user Plant already setup, click on Skip.</p>

ShineTools APP Settings Guide

Step 2: Add SPH 10000TL-HU-US to online account And network configuration

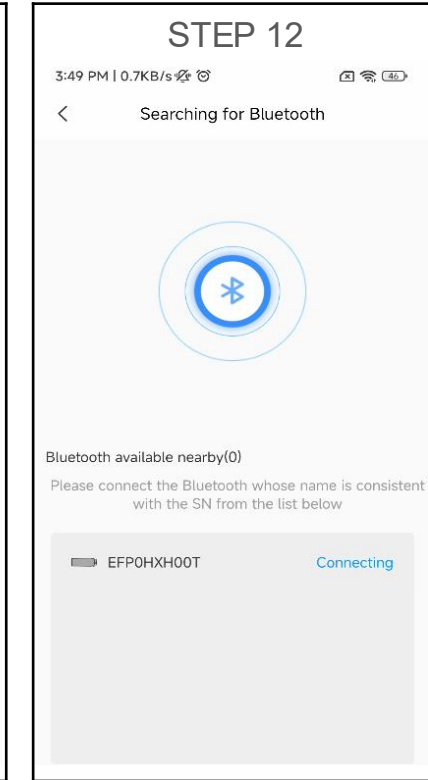
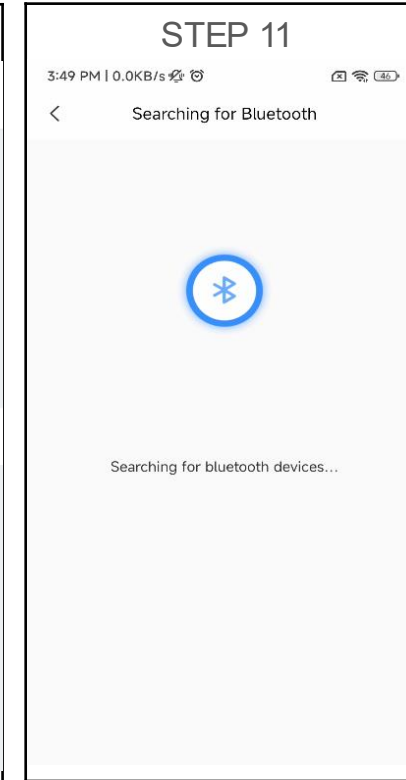
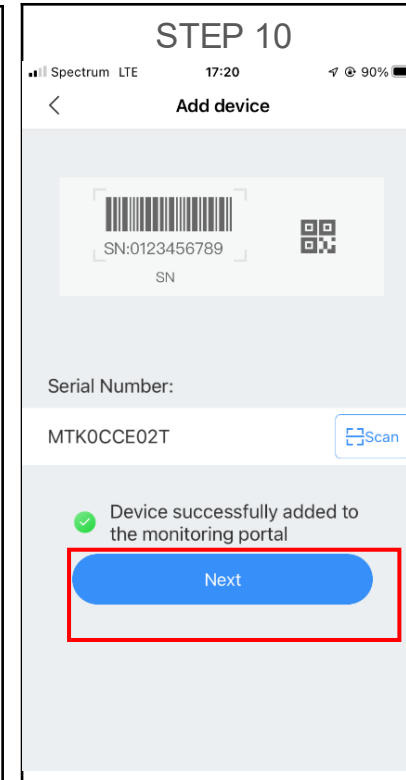
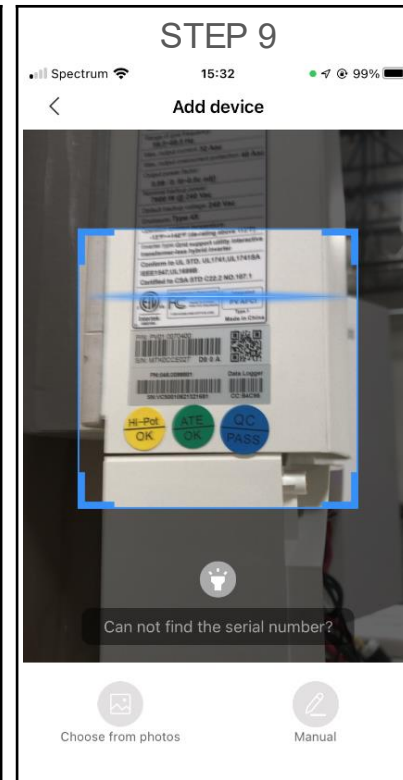
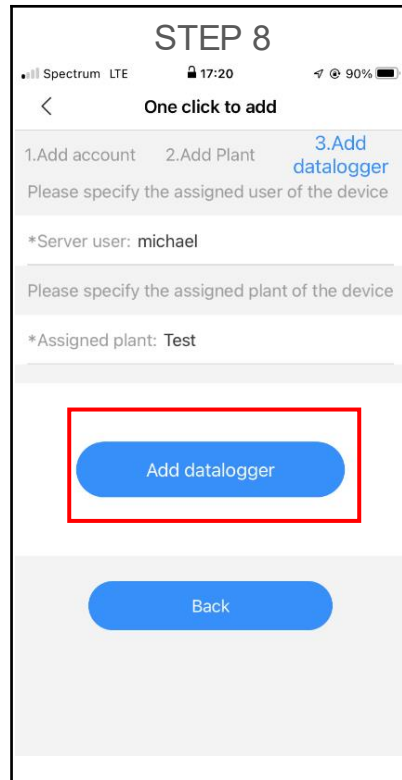
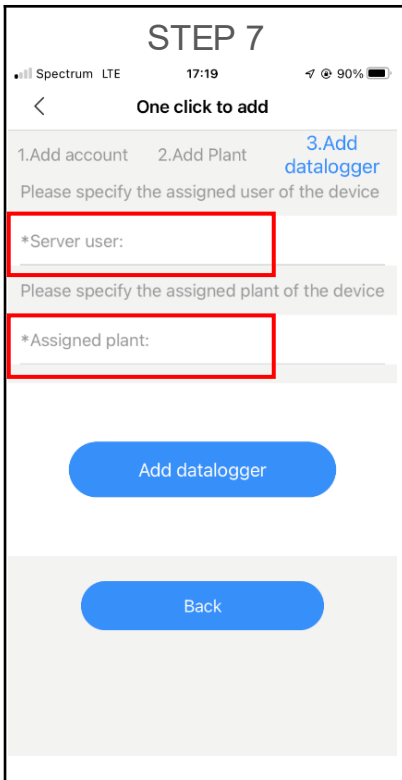

Click on Server user and Assigned plant to choose the user and plant.

Click on Add datalogger

Scan the S/N barcode on the left side of the inverter.

After successful scanning of the S/N, Click Next.

The ShineTools will search for bluetooth signal automatically.

ShineTools will connect to the inverter's bluetooth signal automatically.

ShineTools APP Settings Guide

Step 2: Add SPH 10000TL-HU-US to online account
And network configuration

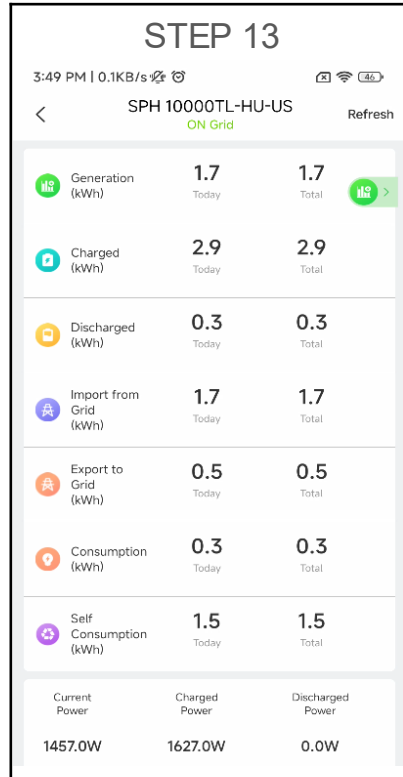

After connecting to inverter's bluetooth signal successfully. The ShineTools will jump to the home page.

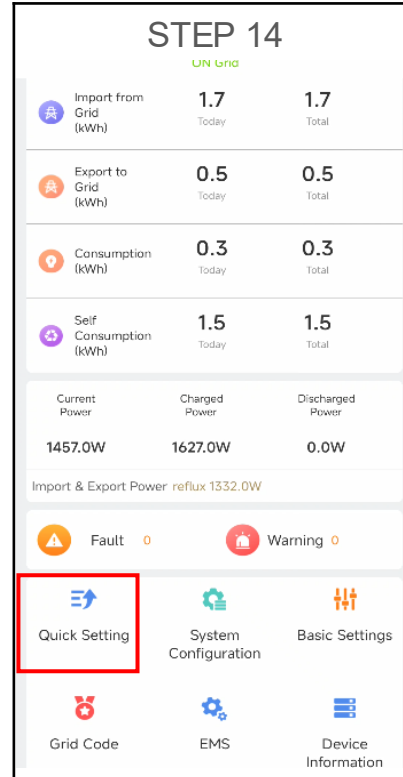

Scrol down and choose quick setting.

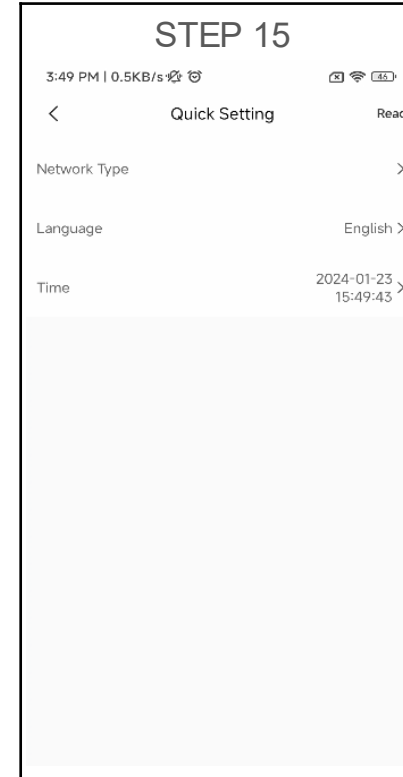

Choose Network Type

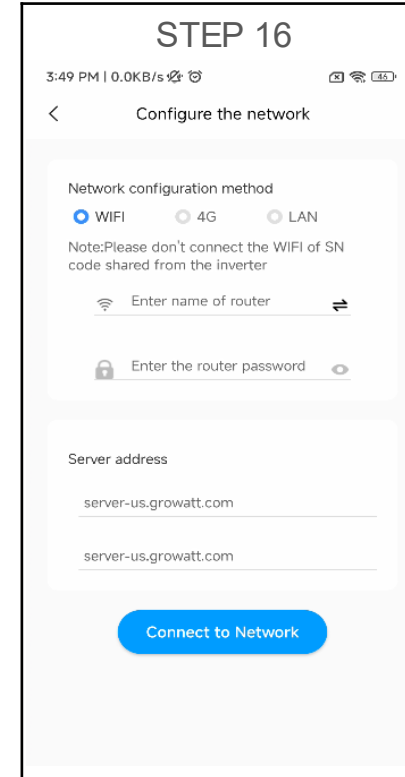

Configure the network

ShineTools APP Settings Guide

Step 3: Grid Code configuration

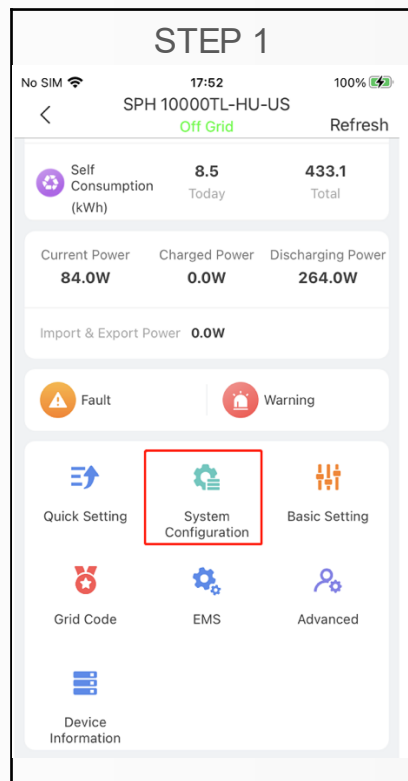

System Configuration

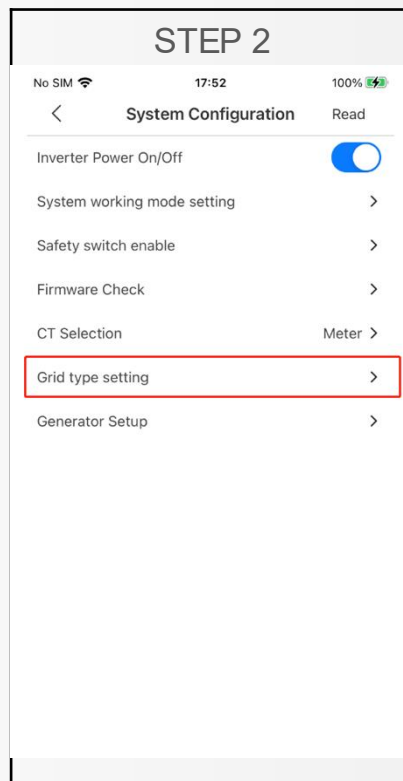

Grid type setting

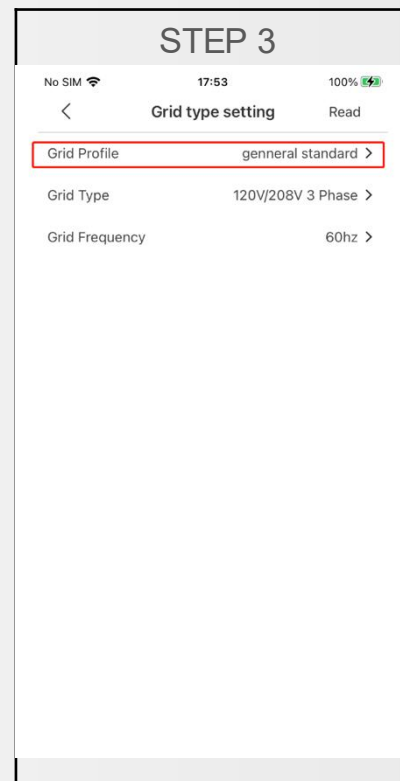

Grid Profile

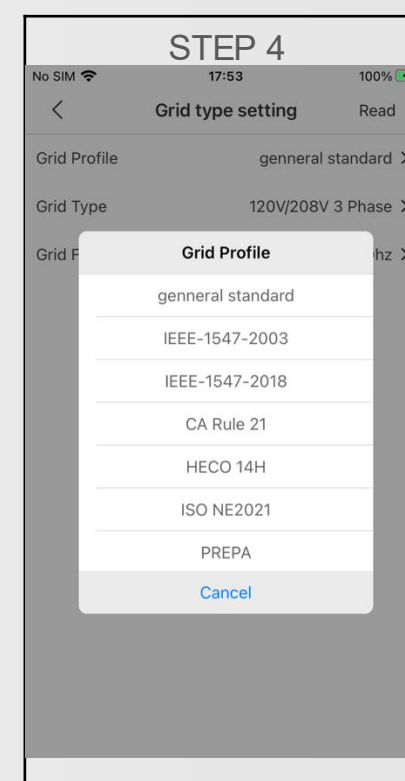

Select the applicable Grid Code

ShineTools APP Settings Guide – Smart Meter/CT Selection

Step 4: Smart Meter/CT Configuration

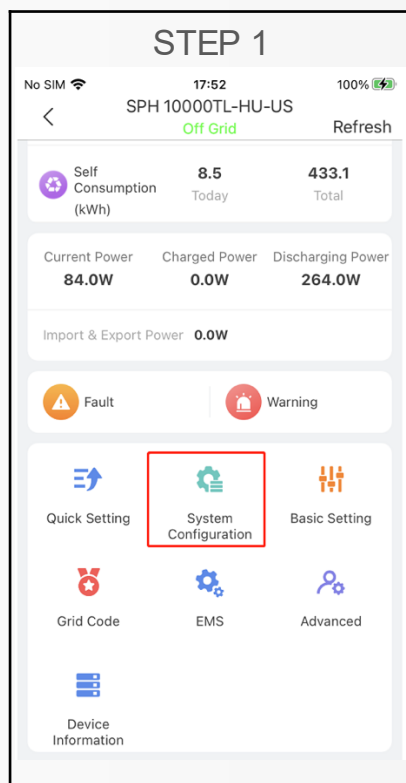

Quick Setting

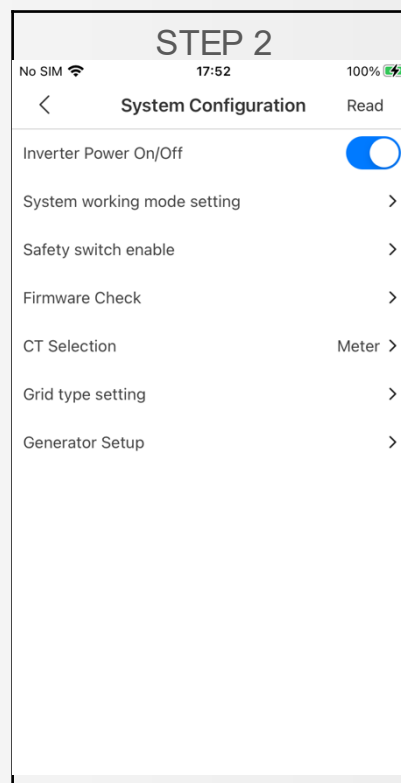

Power Sensor

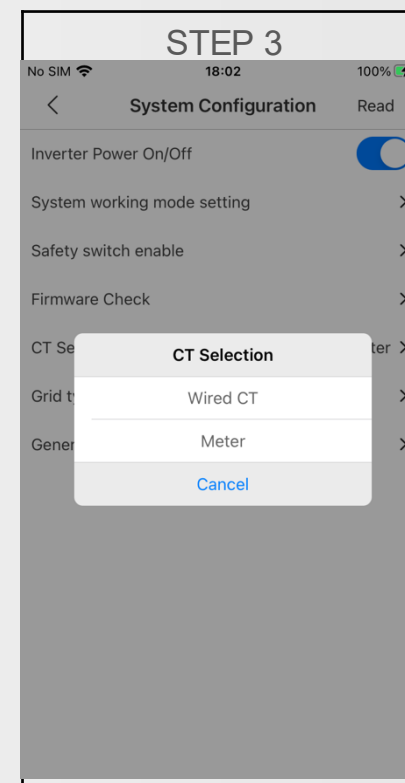

Electric Meter

ShinePhone APP Settings Guide

Step 9: Account Registration

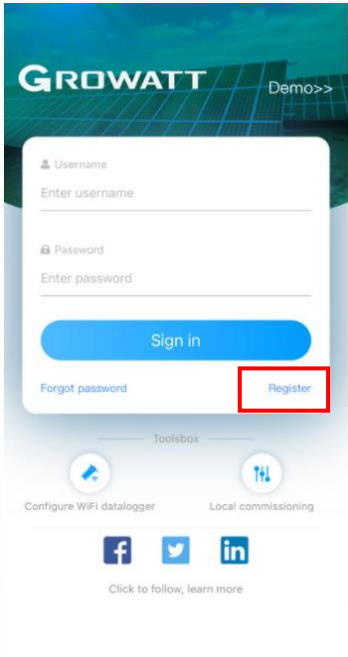
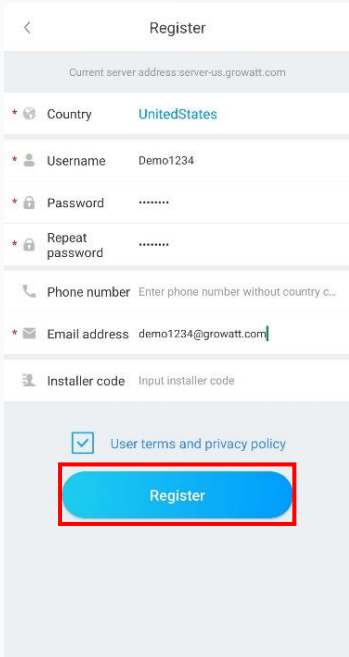
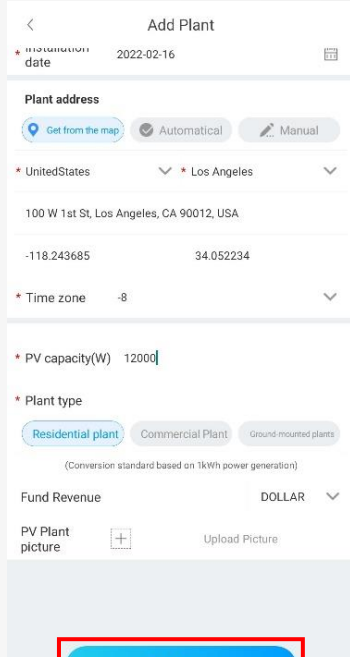
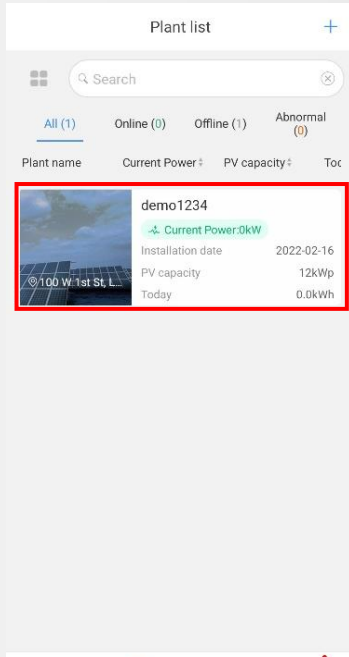
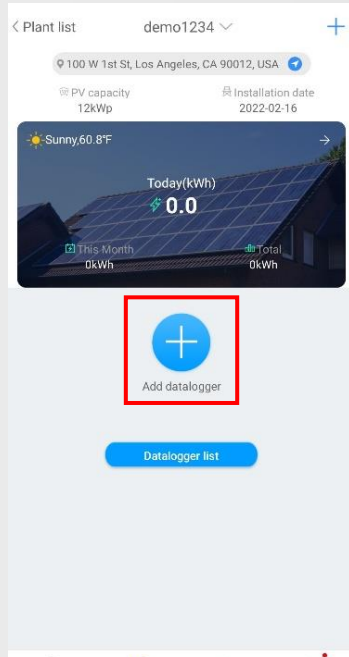
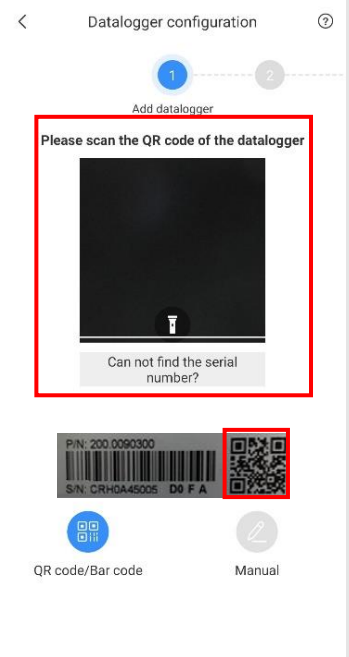
STEP 1	STEP 2	STEP 3	STEP 4	STEP 5	STEP 6
 <p>Register</p>	 <p>Register</p> <p>Input information for all spaces marked with a red *</p>	 <p>Add Plant</p> <p>Input information for all spaces marked with a red *</p>	 <p>Select Plant</p>	 <p>Add Datalogger</p>	 <p>Scan QR Code</p> <p>Scan the QR Code next to the SN # on the left-hand side of the inverter</p>

Shine Phone APP Settings Guide for EV Charger

Step 1: Download & Install the ShineTools APP from Android or iOS App Store

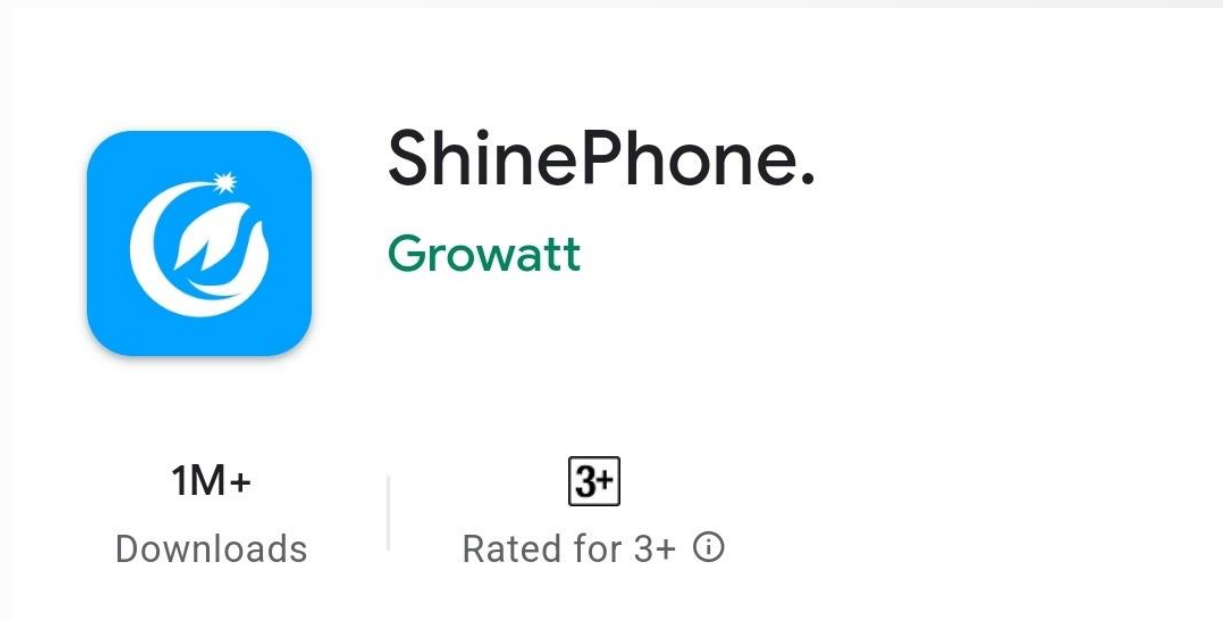

**Shine Phone For Installer
commissioning**

&

**Residential end user
monitoring and use**

ShinePhone APP Interface

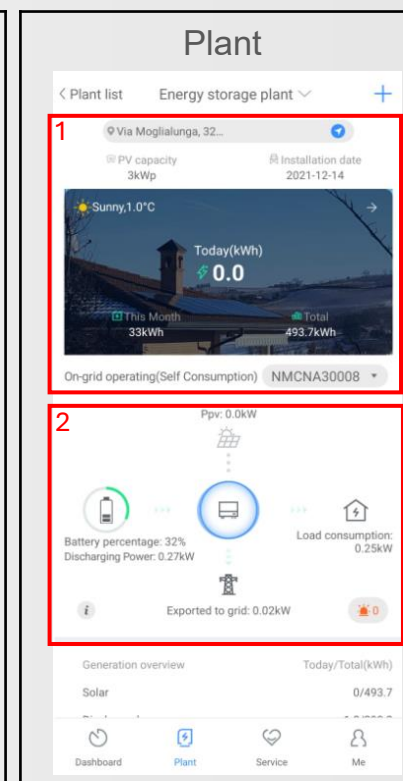
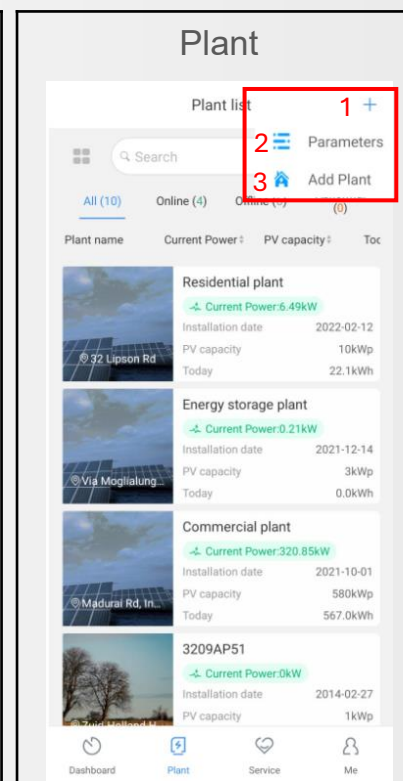
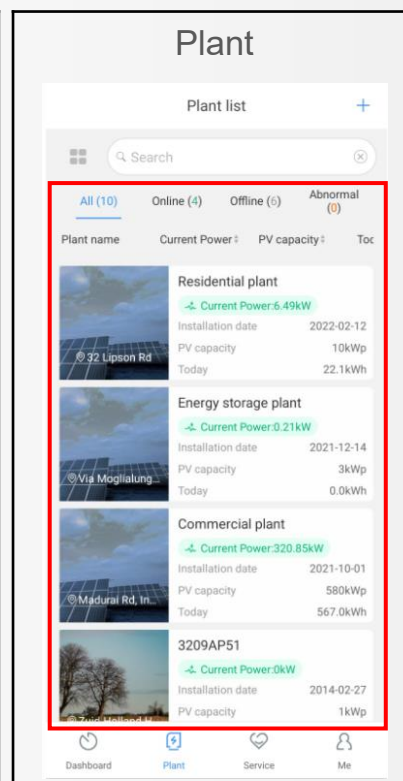
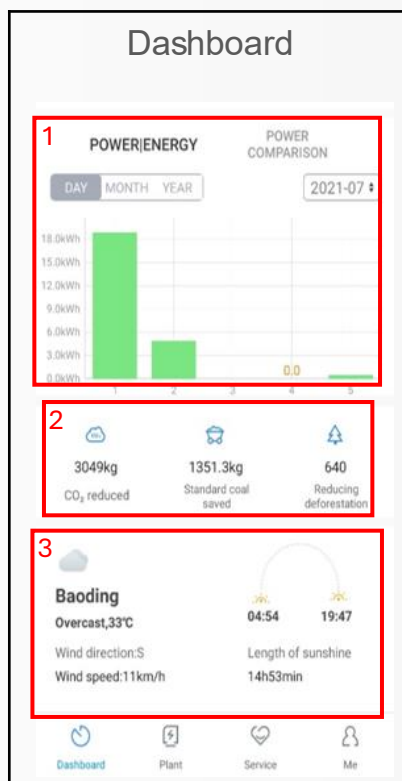
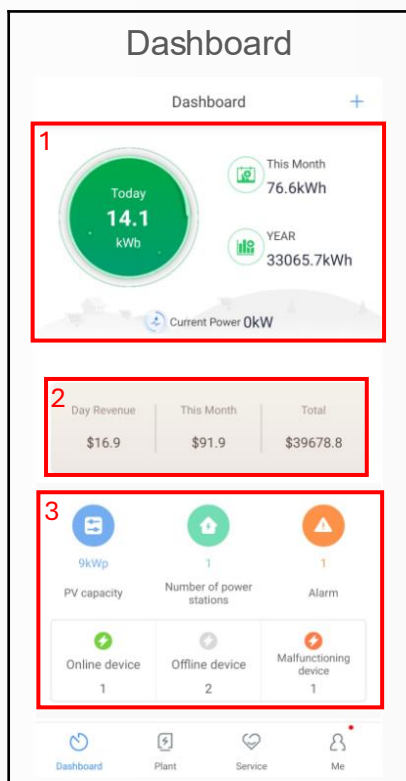

1. Power Generation
2. Revenue
3. System Messages

1. Power/Energy Data
2. Environmental Data
3. Local Environment

List of Plants
Linked to account

1. "+"
2. Parameters
3. Add Plant

System Status
&
Energy Flow

1. Generation Overview
2. Environmental Data
3. Local Environment

ShineServer Interface

ShineServer Monitoring server-us.growatt.com

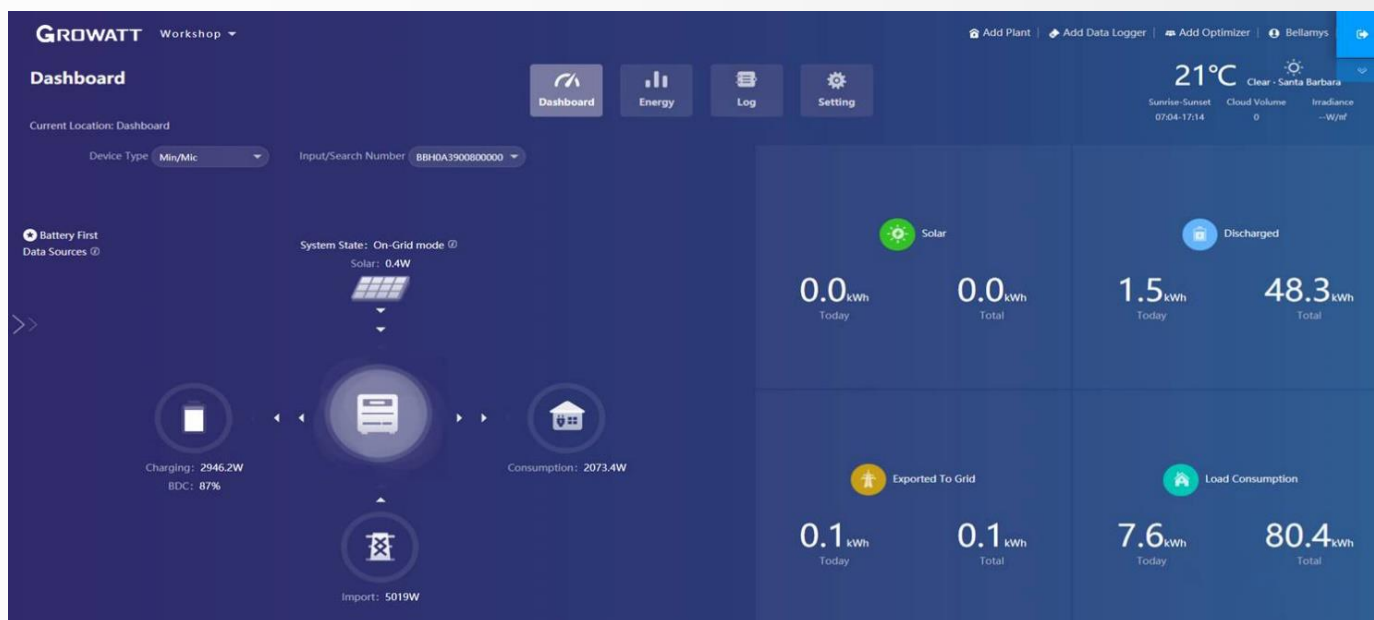

- Real time monitoring
- Remote firmware update & Self Check
- Remote Inverter & Battery functionality modification
- Remote AFCI reset
- Remote EMS Control

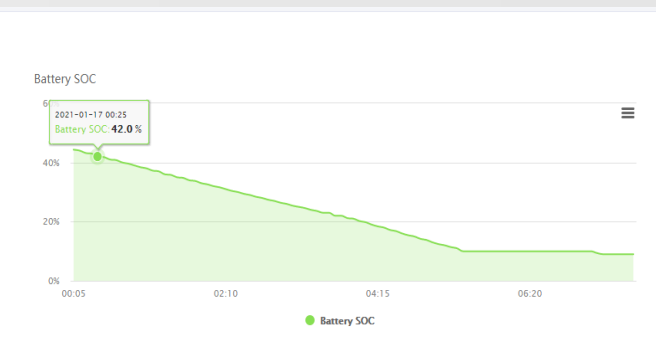
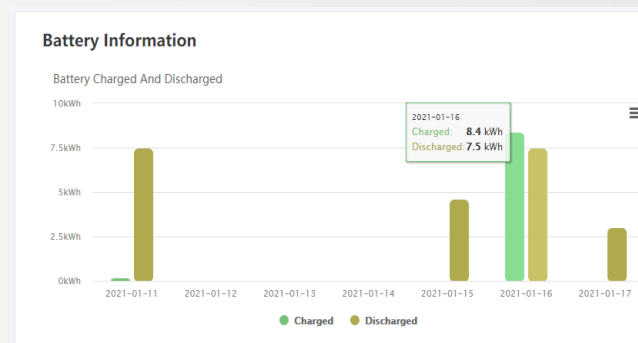

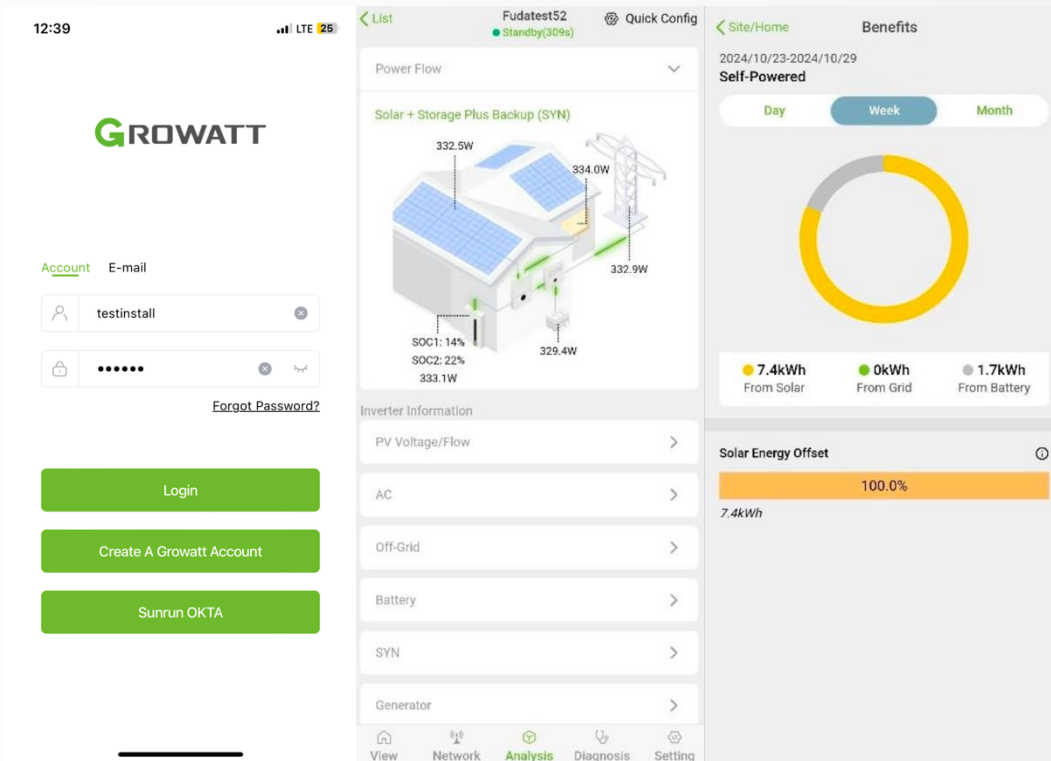

SHINER APP Commissioning & Settings Guide

The right side of the image features a green background with white text and icons. The text reads 'SHINER APP Commissioning & Settings Guide'. Below the text are three white line-art icons: a wind turbine, a solar panel array, and a house with solar panels on its roof.

SHINER App Commissioning

Download

- Download “Shiner” from APP Store or Google Play store



Create an Installer account

- Distributors can contact their sales representative
- Installers can call customer support line: 1-866 686 0298

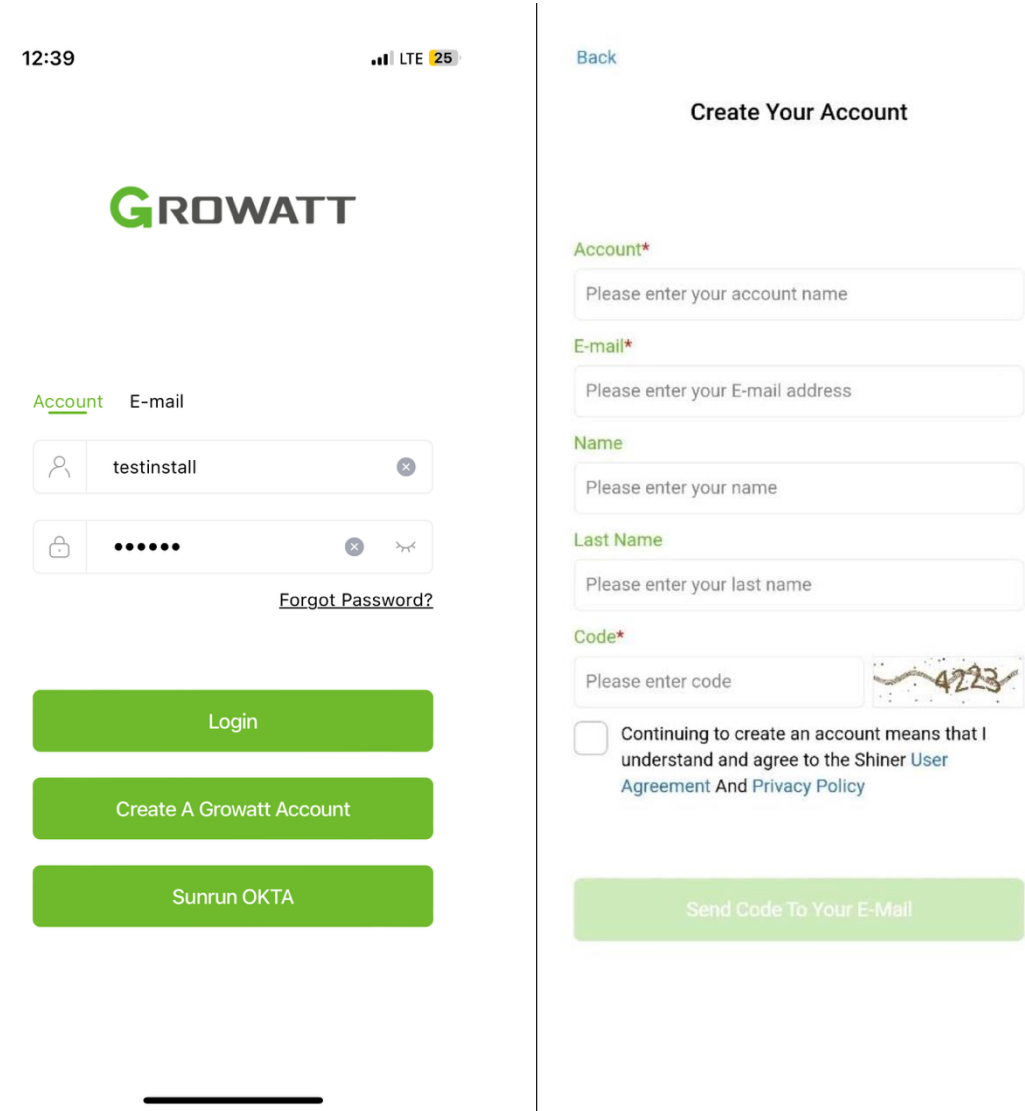

SHINER App Commissioning

Connect to the Inverter

- Turn on Bluetooth
- Click the inverter
- Input the CC from the side of the inverter or scan with your camera to connect

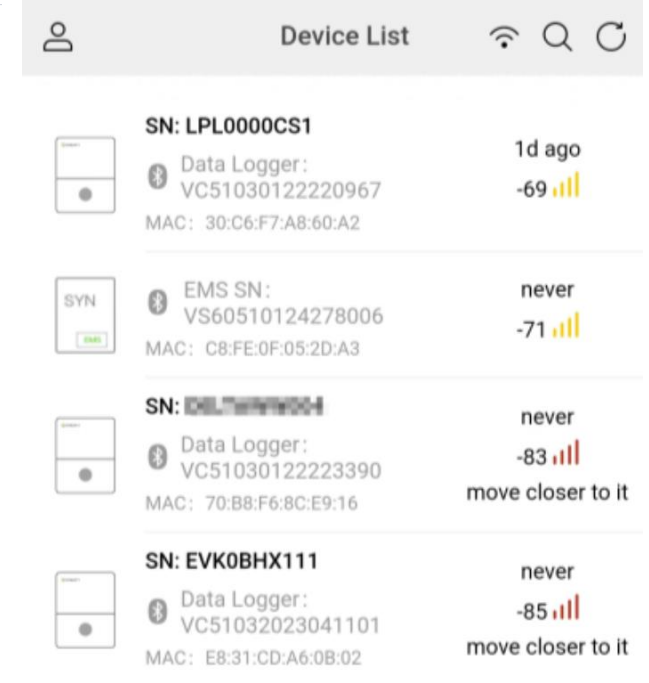
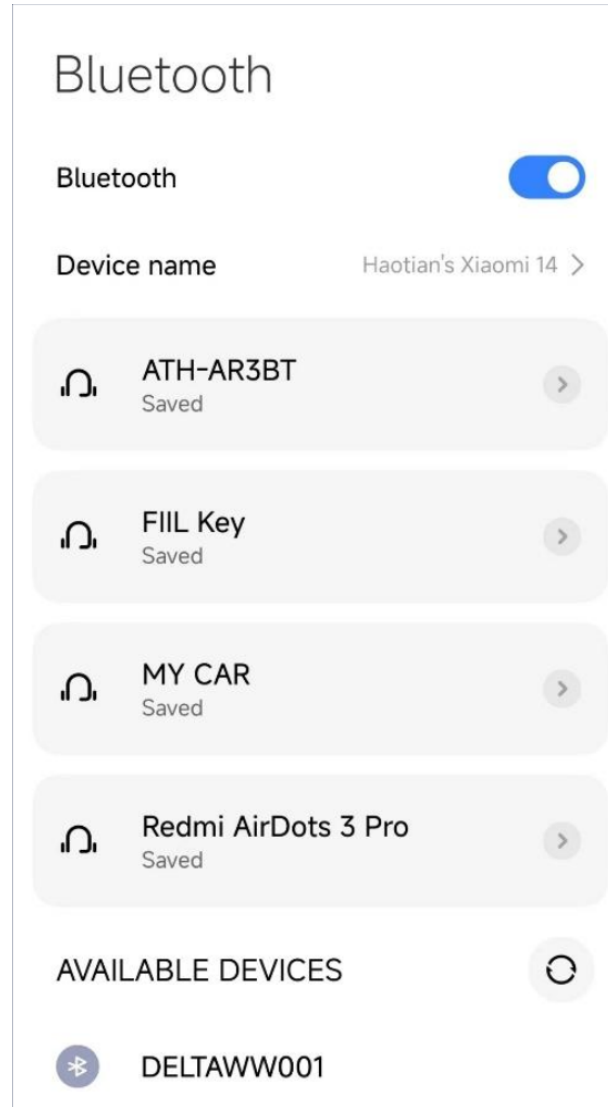

Not found your device?

SHINER App Commissioning

Add Site

- Create a new site for each home address

Add Device

- Bind a device to the created site

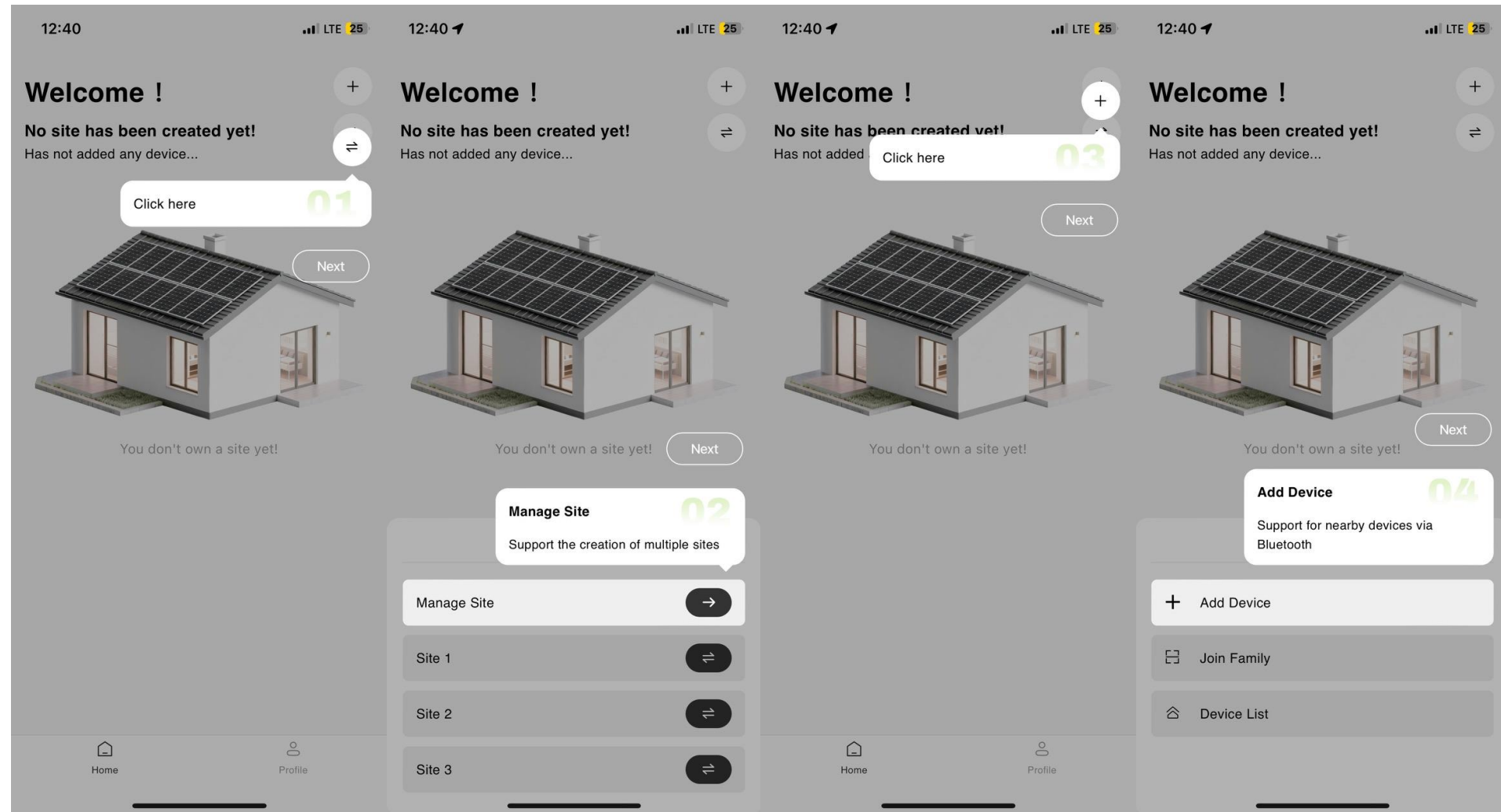

SHINER App Commissioning

Installer View

- See current PV production and Battery activity

Connect to Network

- Connect to wifi

Check for Firmware Upgrades

- Check for Firmware upgrades

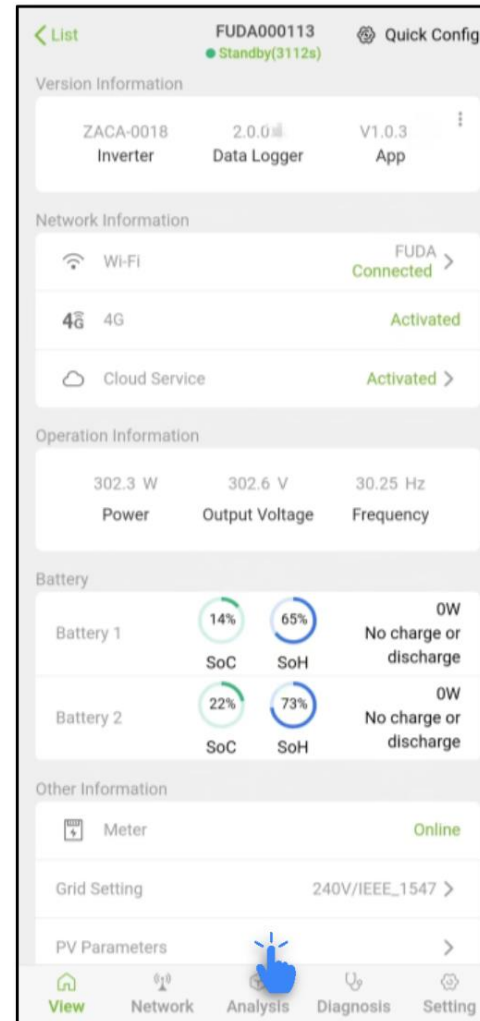

SHINER App Commissioning

Settings Page

- On the settings or quick settings page you can configure: Grid Code, EMS modes, time of use, and pre PTO mode to finish the commissioning

Export

- When confirmed to be working as expected, installers can export all parameters directly to PDF or JPG to their phone photos or email and share

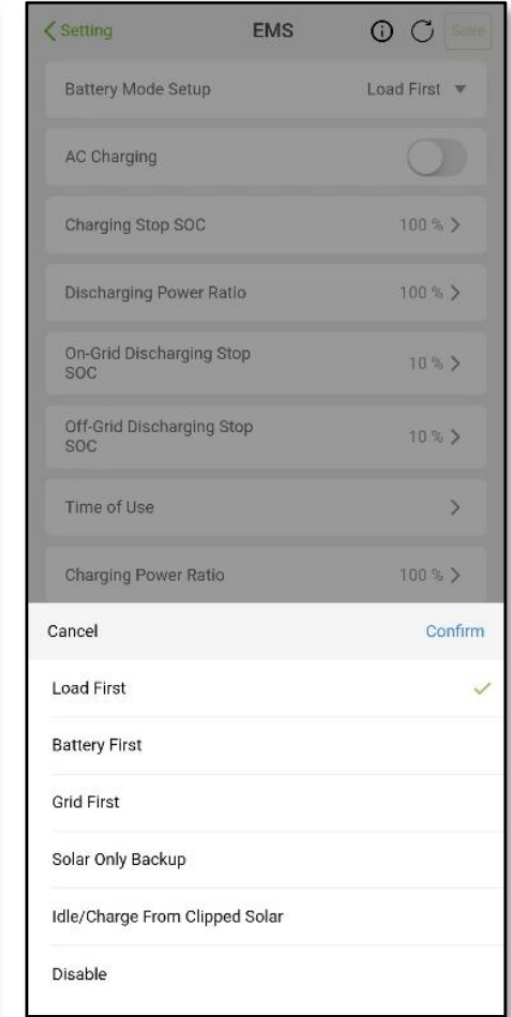
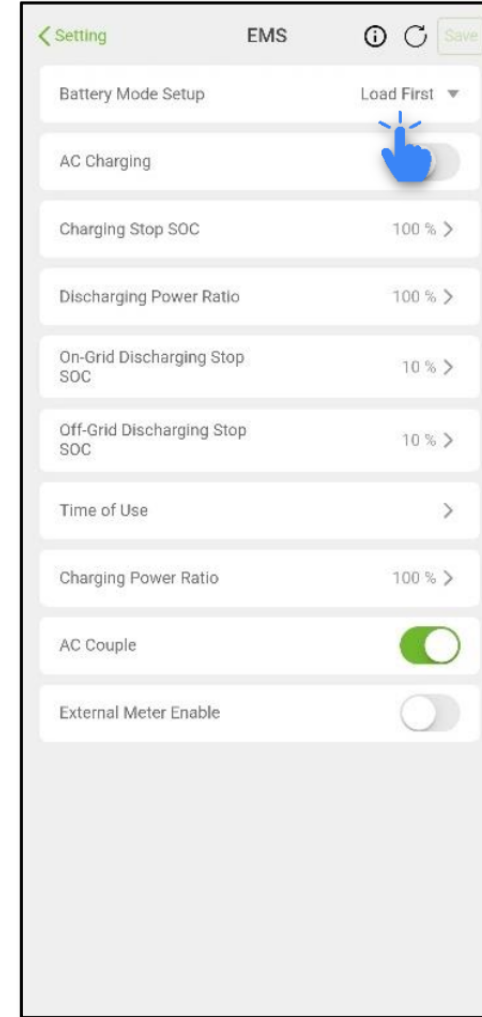
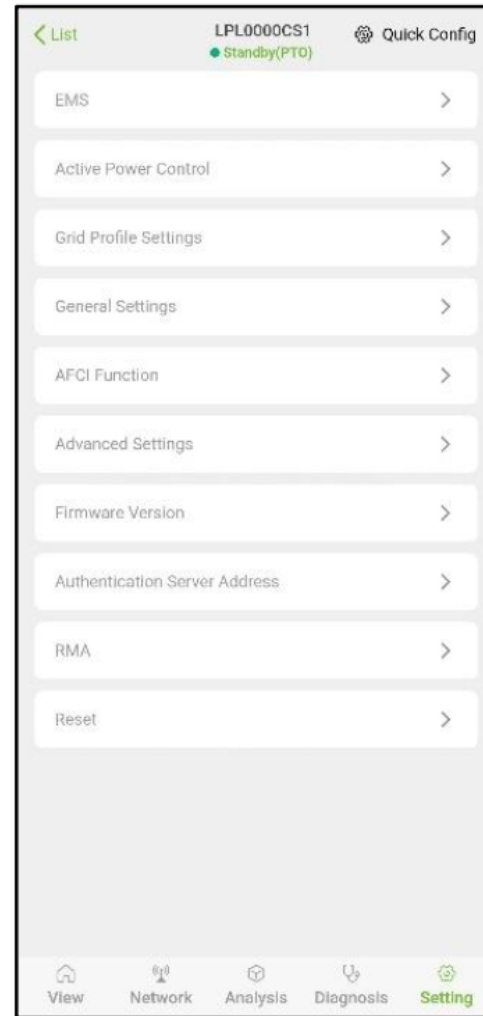

SHINER App Commissioning

End User Profile

- Residential End users can create an account directly within the Growatt SHINER application, and connect to the inverter.

Connecting

- Scan or Input the CC on the side of the device and follow the same process of creating a site, then adding a device

Monitor

- Finally, monitor your device, track self consumption, and energy saved.

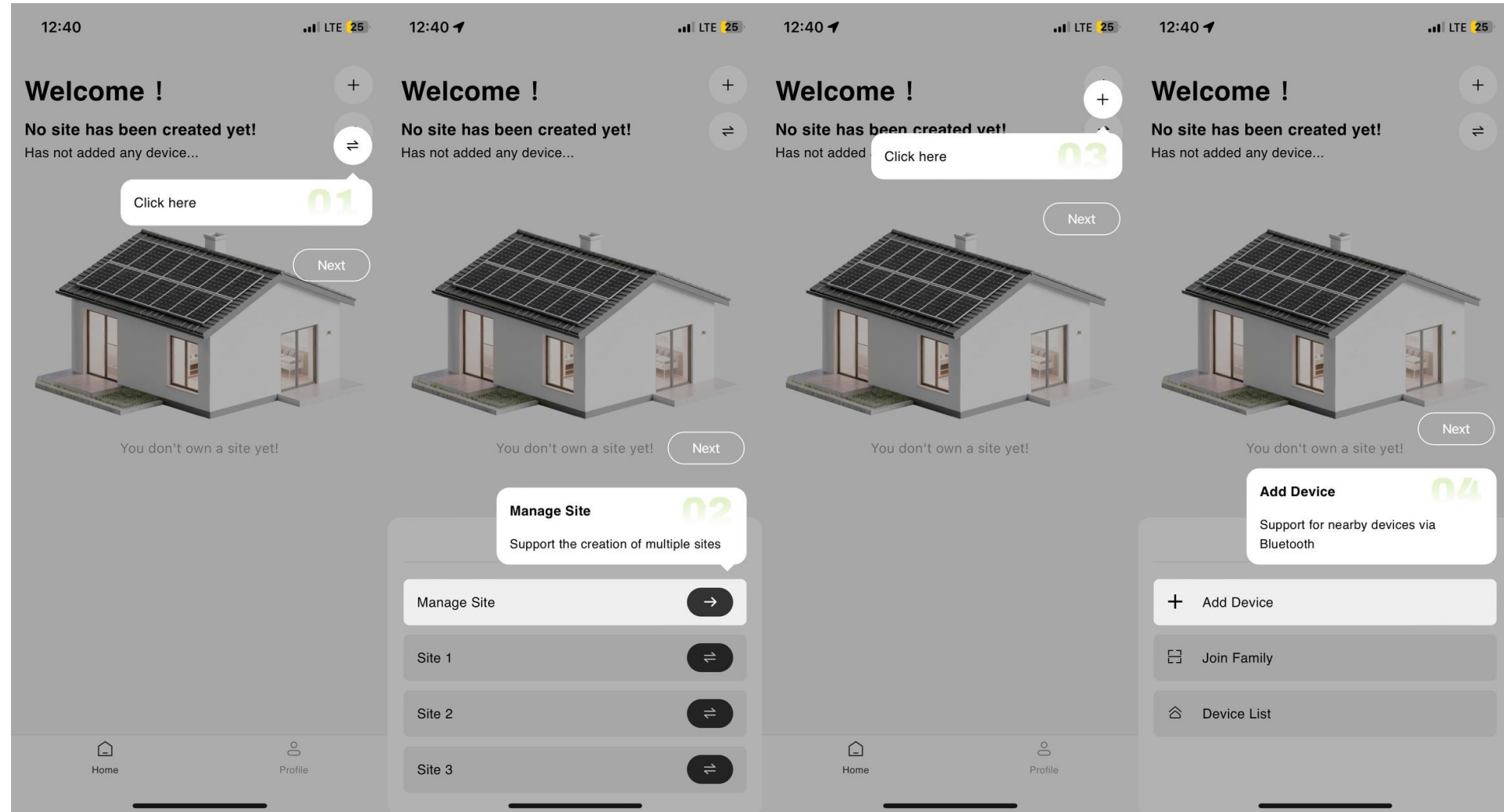

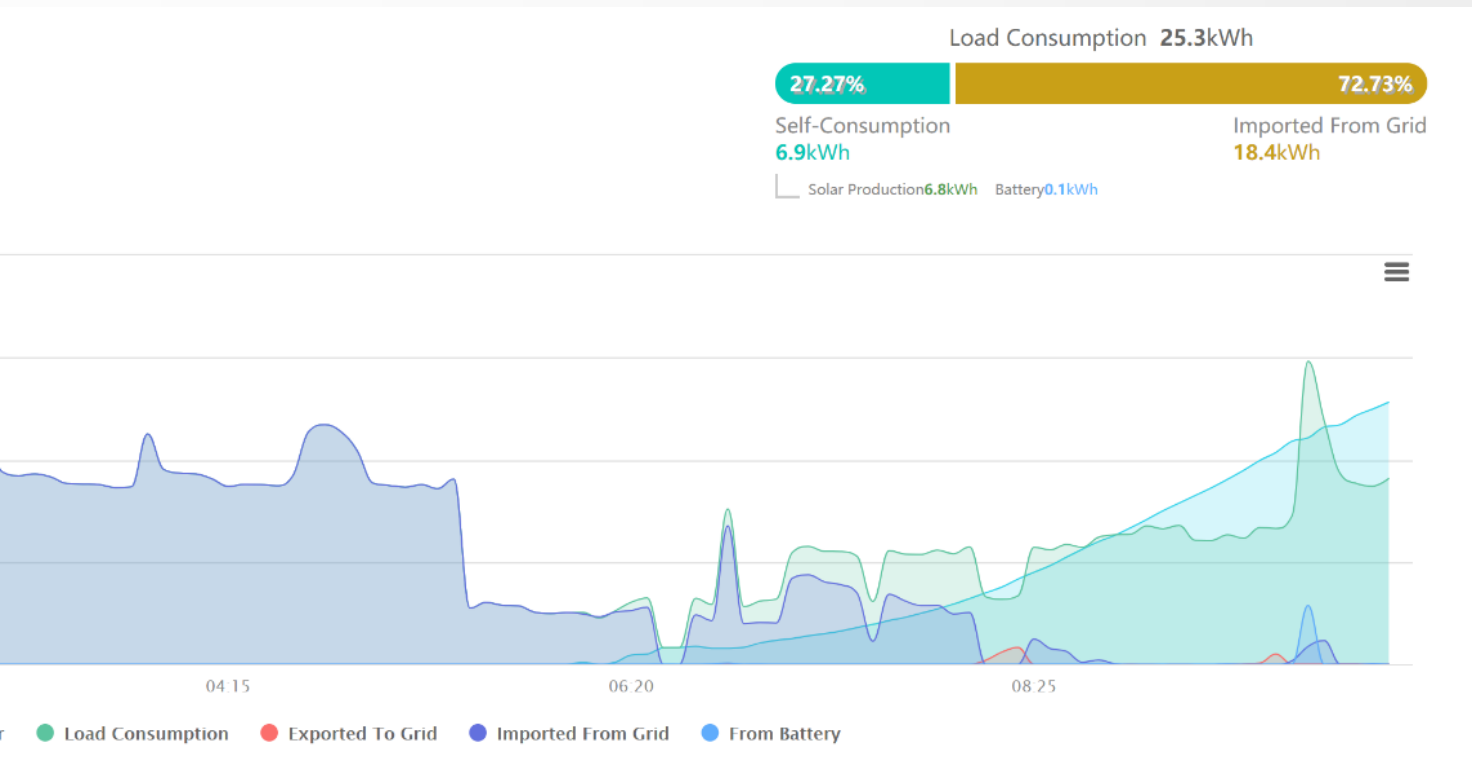

SHINER Server Web Interface Installer Portal



SHENZHEN GROWATT NEW ENERGY CO.,LTD



SHINER Server Monitoring

Distributor Profile

- Shiner server can be accessed at Growatt-US.Vidagrid.com
- Distributor profiles can be created by the Growatt team

Installer Profiles

- Installer profiles can be created by the distributor directly or by calling Growatt support: 1-866-686-0298

End User Profiles

- End user profiles can be created directly within the Growatt Shiner APP or on the Shiner server.

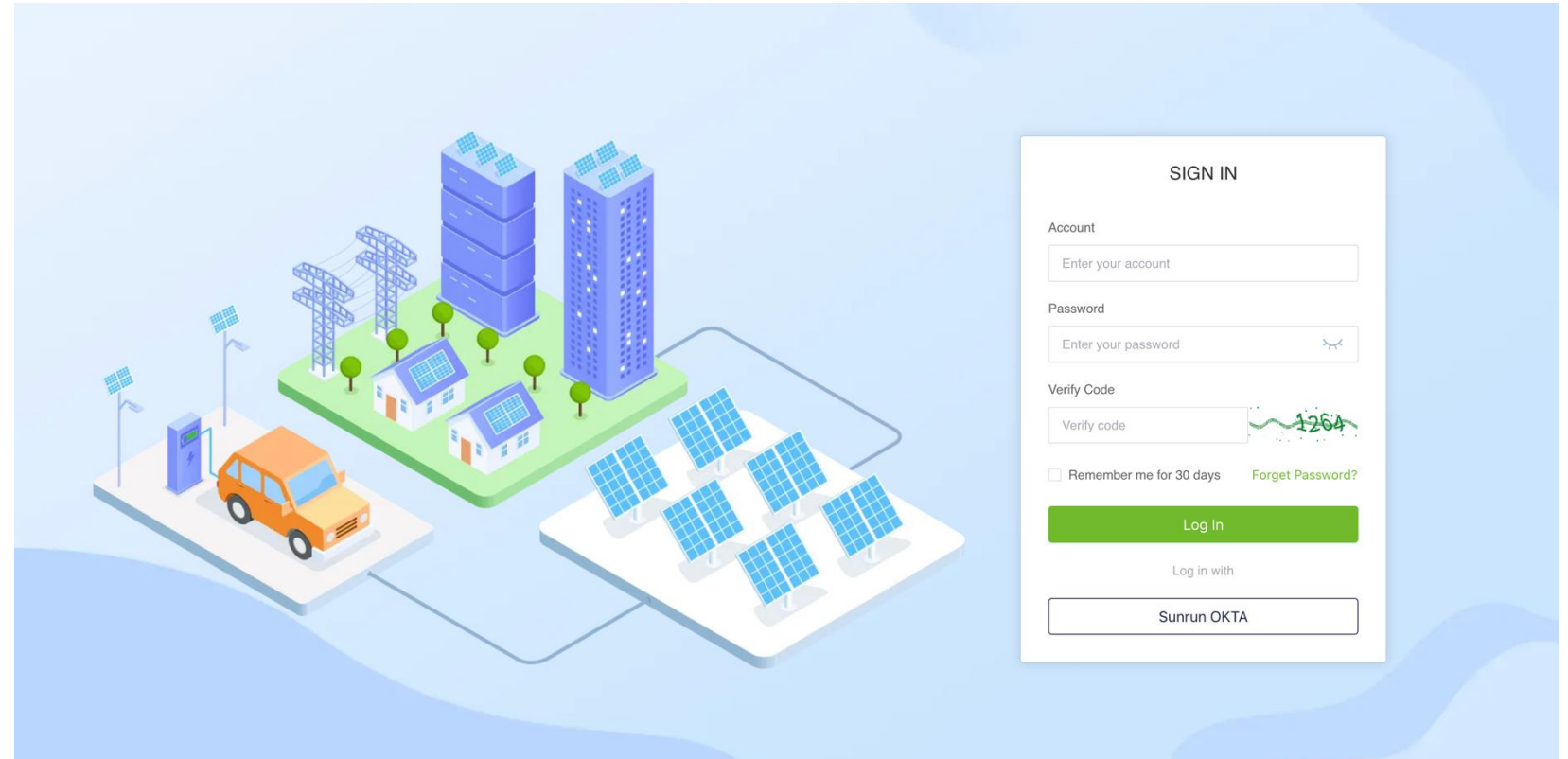

SHINER Server Monitoring

Distributor/Installer Overview

- Overview: See all your sites at once for easy monitoring for abnormalities
- Sites: For seeing all of your previously commissioned sites
- Devices: For seeing all of your individual devices
- O&M: For OTA Firmware upgrades
- Service Hall for Support & RMA's
- Account Manager: For Adding Installers/End Users & Binding devices to sites

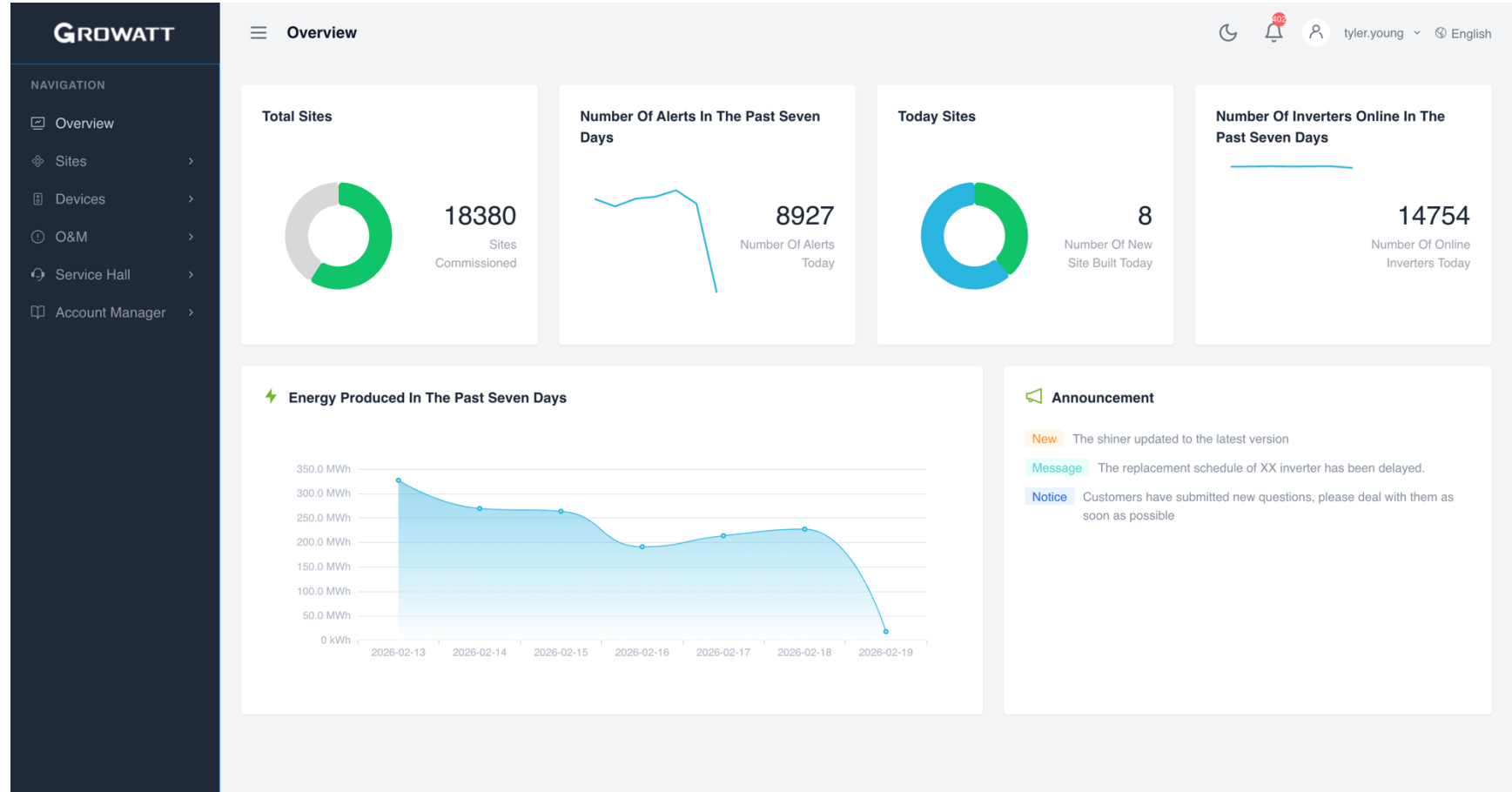

SHINER Server Monitoring

Binding A Device

- Under Account Manager, Select an end user account
- Click “Site List” and create a site, or find the one created by the installer
- On the right hand side, select the “Gear” icon, and type in the Serial Number of the device you’re trying to bind
- Click “Bind” and the device is now bound properly and can be monitored by the end user, installer, and Distributor.

The screenshot shows the 'Account List' page in the GROWATT system. The table contains the following data:

#	Account	Parent Account	Nickname	E-mail	Status	Account Type	Create Time	Actions
1	testenduser	testenduser	test enduser	tyler.young@growatt.com	Online	End User	2025/08/19 16:42:20 UTC -04:00	[Gear Icon]

The screenshot shows the 'Site List' page for the user 'testenduser'. The table contains the following data:

#	Name	Status	Equipment Quantity	Owner	Actions
1	homeowner(homeowner)	Offline	0	testenduser	[Gear Icon]
2	lab01(lab01)	Offline	0	testenduser	[Gear Icon]

Contact



Sales

1-818-800-9455
Info@growatt.com

Support

usaService@growatt.com
866-868-0298

Marketing

925-818-9906
Tyler.Young@growatt.com

Presenters

Ryan.Gravelle@growatt.com
Fermin.Carillo@growatt.com
Tyler.Young@growatt.com
Marco.liu@growatt.com

Q&A THANKS.



Copyright© 2023 Growatt New Energy CO., LTD

All Rights Reserved. The information contained in this document is only for reference purpose and subject to change by company officials.

