

### 1. General information-specification

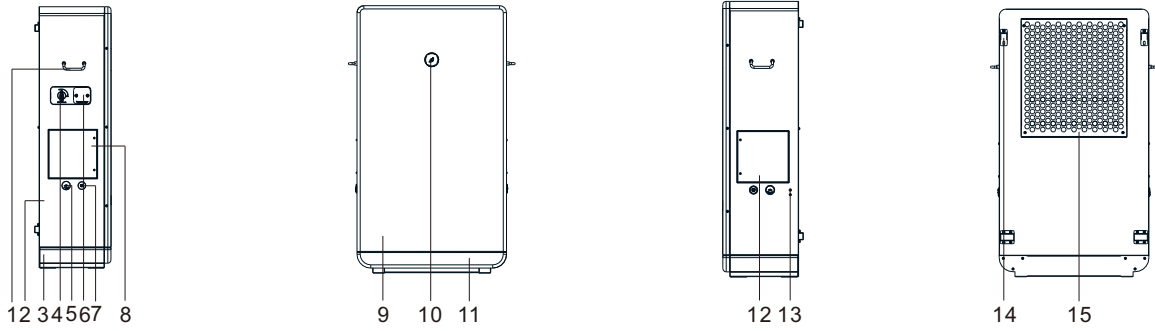

(1) Handle	(2) Box	(3) Base	(4) BAT-switch	(5) Power wire outlet hole
(6) Power button	(7) Signal wire outlet hole	(8) Left-side wiring box	(9) Front cover	(10) LED indicator
(11) Base front cover	(12) Right-side wiring box	(13) Ground port	(14) Install ears	(15) Heat sink

### 2. Installation

#### System overview

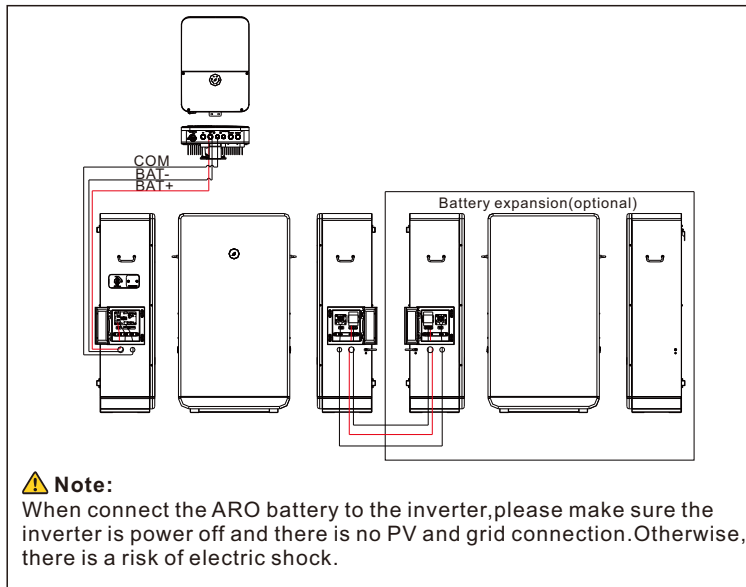

#### 2.1 Installation requirements

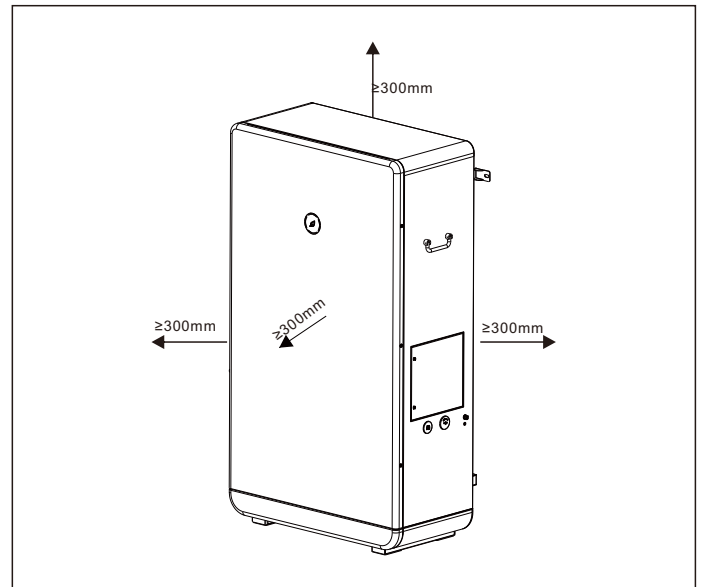

#### 2.2 Floor installation

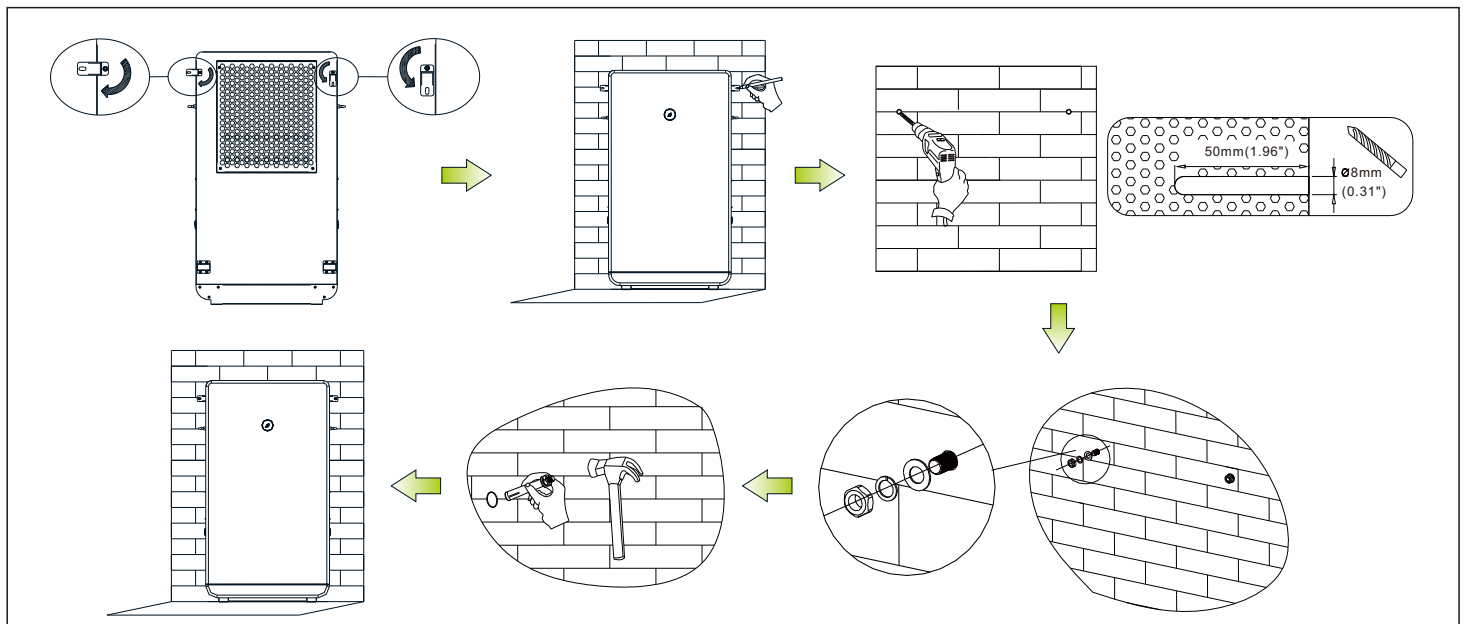

## 2.3 Remove ARO 6.6-19.8H-C1-US' front cover

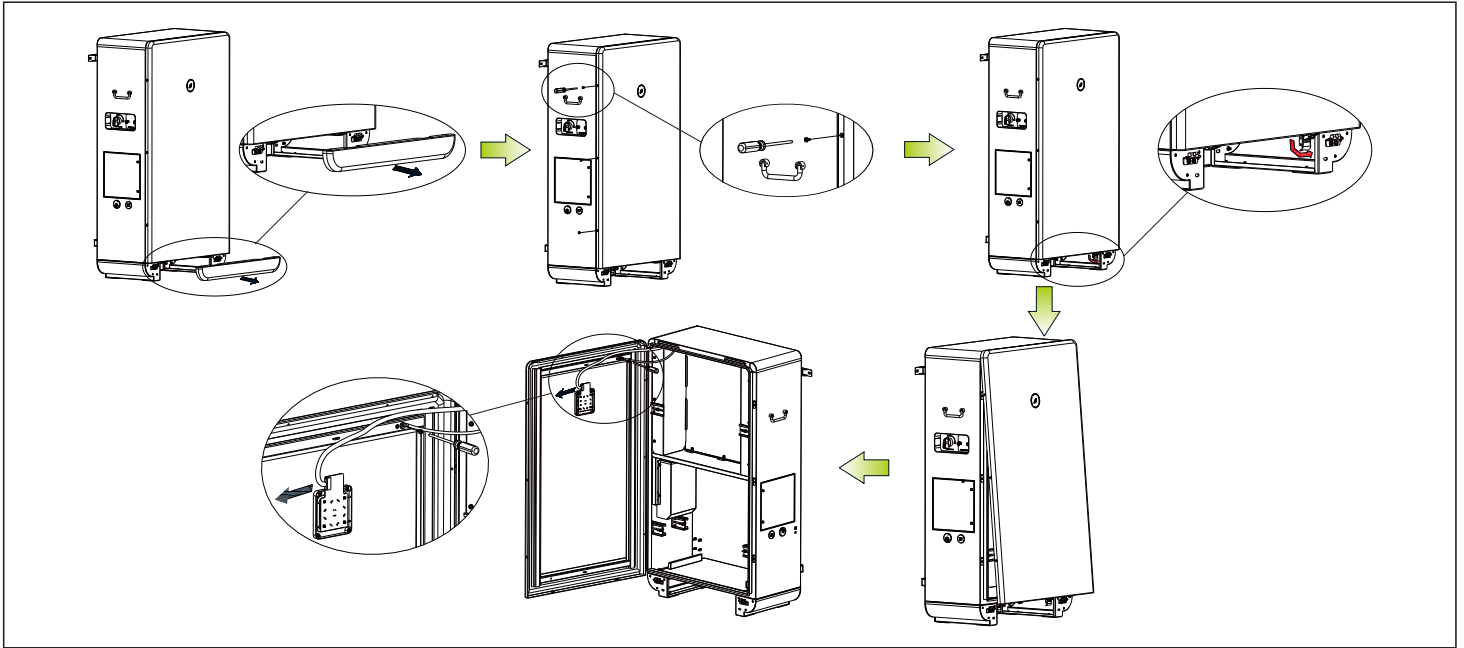

## 2.4 Put in the battery pack

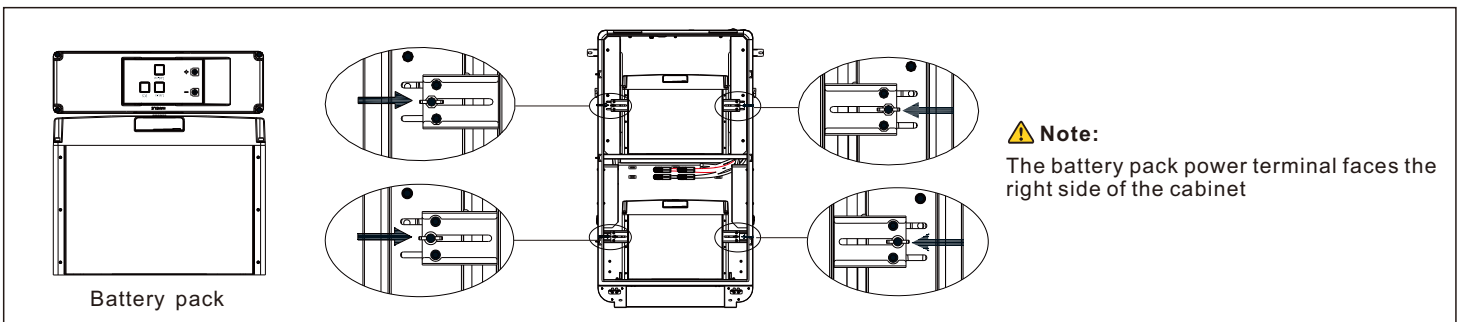

## 3. Connecting Cables

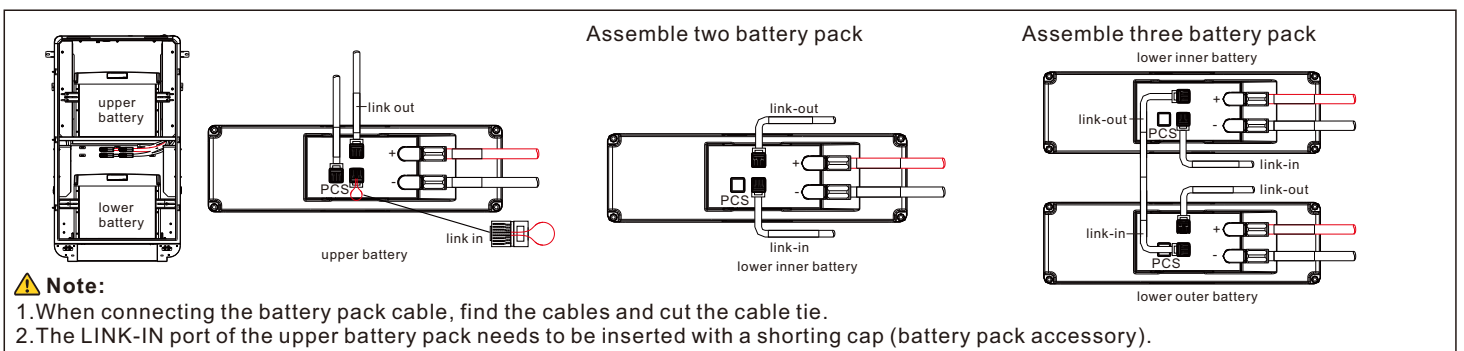

## 4. Connect the terminal

### 4.1 Connect the left side wiring box

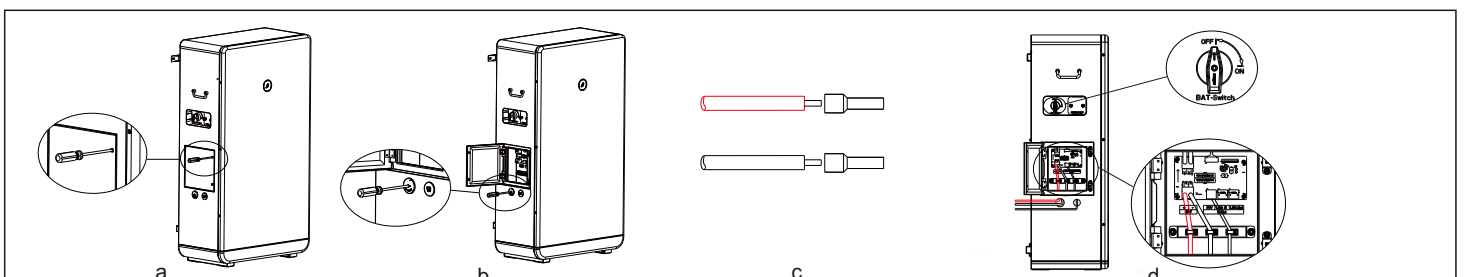

1. Loosen two captive screws of the wiring box on the ARO 6.6-19.8H-C1-US left side with Phillips screwdriver.
2. Remove two waterproof covers at the lower end of the wiring box with slotted screwdriver.
3. Find small round terminals in the accessory bag and choose cables with 4-6mm<sup>2</sup> cross section and crimp them with small round terminals.
4. Connect the waterproof tube head to the holes of the two waterproof caps that were removed. Turn off the BAT-Switch, and connect the wires as shown in the figure. Insert the battery cables made in step 3 into the quick-connect terminals of the silk screen BAT+ and BAT-, and insert the communication cable into the INV port of the silk screen COM.

**(Attention:** the communication cable is a standard network cable which required to be purchased by client. Ensure the inverter is power off and shut down totally when the battery cable and the communication cable connect to the inverter, otherwise there is a risk of electric shock. Make sure to connect battery cable to the inverter first and then connect the communication cable to the inverter).

#### 4.2 Connect the right side wiring box

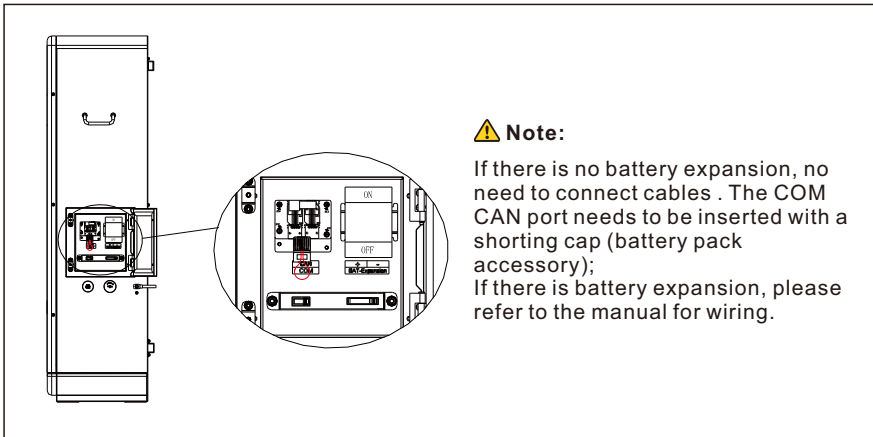

#### 4.3 Ground connection

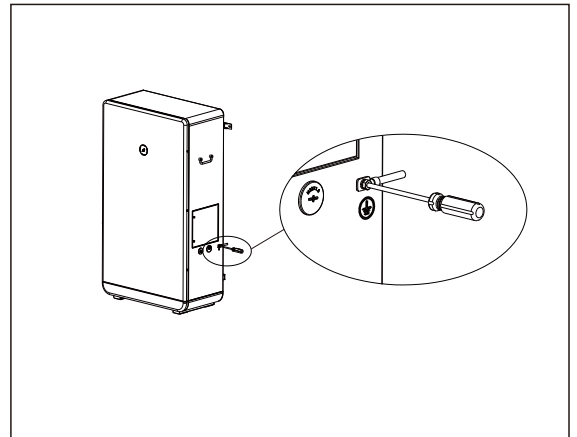

### 5. Verifying the Installation

1. Check whether ARO 6.6-19.8H-C1-US has been connected to inverter, otherwise it cannot start up and work;
2. The Ground cable is connected correctly and securely.
3. The BAT-switch and all the switches connecting to the ARO 6.6-19.8H-C1-US are OFF.
4. The BAT+/BAT- output power cable and signal cable are connected correctly and securely.
5. BAT-Expansion+/BAT-Expansion- power cable and signal cable are connected correctly and securely. (Optional, if there is battery expansion)
6. Unused terminals and ports are locked by watertight caps.

### 6. Powering On/OFF ARO 6.6-19.8H-C1-US

#### 6.2 LED indicator instruction

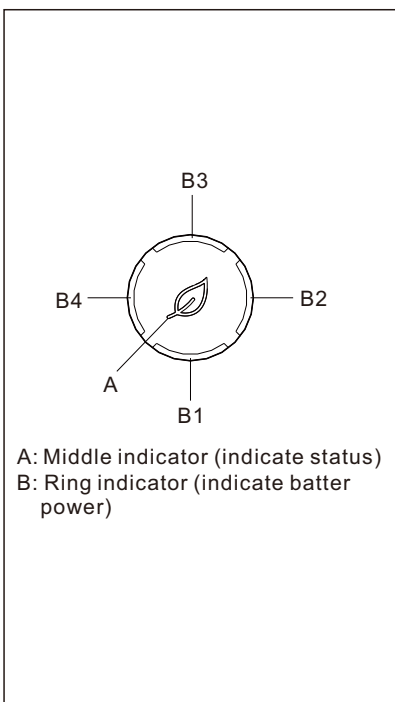

LED lights are displayed as follows in ARO 6.6-19.8H-C1-US different states:

Number	Status	LED light display
1	Standby state	Middle green light flashing (0.5 seconds on and 2 seconds off) indicate the standby state; Ring indicator refer to Discharge state.
2	Charge state	Middle indicator green light is on, Ring indicator indicate: 1>power≤25%, LED B1 flashes, LED B2/3/4 are off; 2>power≤50%, LED B1 is on, LED B2 flashes, LED B3/4 are off; 3>power≤75%, LED B1/2 are on, LED B3 flashes, LED B4 is off; 4>power>75%, LED B1/2/3 are on, LED B4 flashes.
3	Discharge state	Middle indicator green light is on, Ring indicator indicate: 1>power≤25%, LED B1 is on, LED B2/3/4 are off; 2>power≤50%, LED B1/2 are on, LED B3/4 are off; 3>power≤75%, LED B1/2/3 are on, LED B4 are off; 4>power>75%, LED B1/2/3/4 are on.
4	Alarm state	Middle indicator green light flashes (0.5 seconds on and 0.5 seconds off, 0.5 seconds on and 2 seconds off), Ring indicator refer to Discharge state.
5	Fault state	Middle indicator red light flashes (1 second on and 1 second off), Ring indicator refer to Discharge state.
6	Upgrade state	Middle yellow light flashes (1 second on and 1 second off) indicate that the upgrade state; Ring indicator refer to number 1.
7	Manual forced power on	Middle indicator green light flashing (0.1 seconds on and 0.1 seconds off). Ring indicator refer to Discharge state.
8	Manual forced shutdown	Middle red light flashing (0.1 seconds on and 0.1 seconds off). Ring indicator refer to Discharge state.

## 6.2 Powering On ARO 6.6-19.8H-C1-US

6.2.1 If the inverter has PV access or Grid access, or both PV and Grid access, the steps of ARO 6.6-19.8L-C1-US accessing to energy storage system are as follows:

1. Turn on the BAT-switch on the left side of the ARO 6.6-19.8H-C1-US;
2. Open the wiring box on the right side and turn on the BAT-Expansion breaker (optional, if there has battery expansion);
3. Turn on the the inverter, waiting for 10S, the inverter will send a wake-up signal to run the ARO 6.6-19.8H-C1-US. Observing the LED indicator of the ARO 6.6-19.8H-C1-US, confirm that the machine enters the discharge state(the Middle green light is on), indicating that ARO 6.6-19.8H-C1-US has been successfully started by the inverter.

6.2.2 If the inverter has no PV accessing and no mains accessing, the steps of ARO 6.6-19.8H-C1-US accessing to energy storage system are as follows:

1. Turn on the BAT-switch on the left side of the ARO 6.6-19.8H-C1-US;
2. Open the wiring compartment on the right side and turn on the BAT-Expansion breaker (optional, if there has battery expansion) ;
3. Long press power button for  $\geq 3S$ ,  $\leq 10S$  (please refer to Part 7 for power button operation), and observe the LED Middle indicator until the middle green LED flashes quickly ( 0.1 seconds on and 0.1 seconds off), then you can release the button. Wait for 10S, observe the LED indicator, and confirm that the machine enters the standby state (the Middle green light flashing, 0.5 seconds on and 2 seconds off), indicating that ARO 6.6-19.8H-C1-US has been manually forced to start successfully.

## 6.3 Powering OFF ARO 6.6-19.8H-C1-US

Under normal charging and discharging state, if you need to force shutdown ARO 6.6-19.8H-C1-US. You can long press Power button for  $\geq 3S$ ,  $\leq 10S$  (please refer to Part 7 for power button operation), and observing the LED middle indicator ,until the middle LED changes from green to red ,and flashing quickly(0.1 seconds on and 0.1 seconds off), the button can be released. Wait for 10S, observe the LED indicator, and confirm that the machine enters the standby state (Middle green light flashing, 0.5 seconds on and 2 seconds off), indicating that ARO 6.6-19.8H-C1-US has been manually forced to shut down successfully. Then turn off BAT-Switch.

## 7. Power button operation

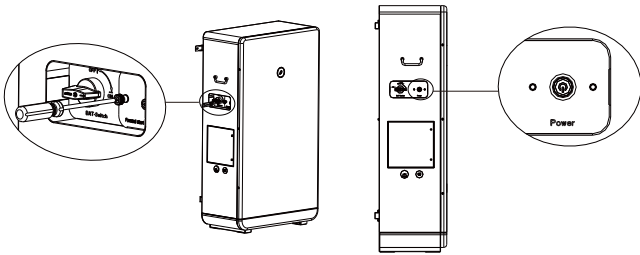

Forced start/shut down ARO 6.6-19.8H-C1-US power supply steps:

1. Disengage the captive screws of cover of the forced start button with Phillips screwdriver.
2. Press and hold the button with your finger, see section 6.2.2 and section 6.3 for the button holding time.
3. After the forced start/shut down is successful, install the cover back removed in the first step.

## 8. Service and contact

Growatt USA, Inc.  
9227 Reseda Blvd, #435 Northridge, CA 91324, USA.

T +1-866-686-0298  
E [usaservice@ginverter.com](mailto:usaservice@ginverter.com)  
W [us.growatt.com](http://us.growatt.com)



Download  
Manual



Growatt New Energy

GR-UM-207-A-01